

# **YASKAWA**

# **SOLECTRIA SOLAR**

**PVI 23TL**

**PVI 28TL**

## **INSTALLATION AND OPERATION MANUAL**

Revision J

[Generation III (SN Prefixes 101301 and 101302)]

© 2017, Yaskawa – Solectria Solar



## **IMPORTANT REGISTRATION AND WARRANTY INFORMATION**

For warranty to become active, this inverter must be registered. To activate warranty and register inverter, please visit the link below.

[www.solectria.com/registration](http://www.solectria.com/registration)

## IMPORTANT SAFETY INSTRUCTIONS

In this manual, “inverter” or “inverters” refers to the inverter models: PVI 23TL and PVI 28TL, unless one of the specific models is noted.

This manual contains important instructions that shall be followed during installation and maintenance of the inverter.

To reduce the risk of electrical shock, and to ensure the safe installation and operation of the inverter, the following safety symbols are used to indicate dangerous conditions and important safety instructions:



**WARNING:** This symbol, along with the word “**WARNING**”, indicates a fact or feature important for the safety of the user and/or which can cause serious hardware damage if not applied appropriately.

**Use extreme caution when performing this task.**



**NOTE:** This indicates a feature that is important either for optimal and efficient use or system operation.



**EXAMPLE:** This indicates an example.

## SAVE THESE INSTRUCTIONS

## IMPORTANT SAFETY INSTRUCTIONS

- All electrical installations shall be performed in accordance with all applicable local, American, or Canadian electrical codes.
- The inverter contains no user-serviceable parts. Please contact Solectria Renewables or a Solectria Renewables authorized system installer for maintenance. See Appendix C for Solectria Renewables contact information and Appendix D for information regarding authorized system installers.
- Before installing or using the inverter, please read all instructions and caution markings in this manual as well as those on the inverter and PV modules.
- Connection of the inverter to the electric utility grid must be completed after receiving prior approval from the utility company and must only be performed by qualified personnel.
- Completely cover the surface of all PV arrays with an opaque material before wiring them. PV arrays produce electrical energy when exposed to light and could create a hazardous condition.



### **DANGER!**

#### **Danger to life due to fire or explosion:**

Despite careful construction, electrical devices can cause fires.

- Do not mount the inverter on flammable construction materials.
- Do not mount the inverter in areas where highly flammable materials are stored.
- Do not mount the inverters in areas with a risk of explosion

## SAVE THESE INSTRUCTIONS

## PRESCRIPTIONS DE SECURITE IMPORTANTES

- Tous les travaux d'installation électrique doivent être exécutés en conformité aux normes électriques locales ainsi qu'à la norme nationale américaine et canadienne.
- Le PVI ne contient aucune pièce requérant un entretien effectué par l'utilisateur. Pour toute maintenance, veuillez consulter Solectria Renewables ou un installateur agréé par Solectria Renewables (les coordonnées de Solectria Renewables et des installateurs agréés sont indiquées sur le site web de Solectria Renewables: [www.solren.com](http://www.solren.com)).
- Avant d'installer ou d'utiliser le PVI veuillez lire toutes instructions et toutes les mises en garde présentes dans ce manuel, sur le SGI et sur les modules PV.
- Le raccordement du PVI au réseau électrique ne doit être effectuée qu'après avoir obtenu une entente d'interconnexion auprès de la compagnie locale de distribution électrique et uniquement par du personnel autorisé et qualifié.
- La surface de tous les capteurs PV doivent être recouverte entièrement d'un matériel opaque

- (noir) avant de procéder au câblage. Les capteurs PV exposés a la lumière produisent du courant électrique susceptible de créer une situation de risque.

## **CONSERVEZ CES INSTRUCTIONS**

# Table of Contents

<b>1.0</b>	<b>Introduction .....</b>	<b>7</b>
1.1	PVI 23-28TL Inverter Enclosure .....	9
1.2	PVI 23-28TL Inverter Main Parts and Accessories .....	10
<b>2.0</b>	<b>Site Preparation and Inverter Placement .....</b>	<b>12</b>
2.1	Criteria for Device Mounting .....	12
<b>3.0</b>	<b>Inverter Mounting .....</b>	<b>14</b>
3.1	Checking for Shipping Damage .....	14
3.2	Unpacking and Moving the Inverter into Place .....	14
3.3	Inverter Positioning and Mounting.....	15
3.4	Installing the Mounting Bracket.....	18
<b>4.0</b>	<b>Grounding Connections.....</b>	<b>21</b>
4.1	Inverter Knockouts.....	21
4.2	DC/AC Grounding.....	22
<b>5.0</b>	<b>DC Connections from the PV Array .....</b>	<b>23</b>
5.1	DC Wiring .....	24
5.2	Dual Maximum Power Point Tracking.....	26
5.3	Fuse Bypass OPT-FUSEBYPASS-PVI-23-28.....	28
<b>6.0</b>	<b>AC Connections at the Inverter .....</b>	<b>30</b>
6.1	AC Interconnections to Grid.....	31
<b>7.0</b>	<b>Communication Connections.....</b>	<b>32</b>
7.1	Modbus (RS-485) Network Connections with External Monitoring Systems.....	34
7.2	Connecting TL Inverters using SolrenView Monitoring Option .....	39
7.3	Dry Contact Communication .....	40
<b>8.0</b>	<b>Commissioning the Inverter PV System.....</b>	<b>44</b>
8.1	Turning On the Inverter .....	44
8.2	Operation .....	44
8.3	Turning Off the Inverter .....	44
<b>9.0</b>	<b>LCD and LED Indicators.....</b>	<b>45</b>
9.1	LCD .....	45
9.2	Screen Descriptions.....	47
<b>10.0</b>	<b>Troubleshooting and Inverter Messages .....</b>	<b>51</b>
<b>11.0</b>	<b>Product Maintenance.....</b>	<b>55</b>

11.1	Check the Electrical Connection .....	55
11.2	Clean the Air Vent Filter .....	55
<b>12.0</b>	<b>Product Warranty and RMA Policy .....</b>	<b>56</b>
12.1	Warranty and Registration.....	56
<b>13.0</b>	<b>Technical Data.....</b>	<b>56</b>
13.1	Output AC Specifications .....	56
13.2	Input DC (PV) Specifications.....	57
13.3	Other Specifications .....	57
13.4	Temperature Derating Curve .....	58
13.5	Power Derating Curve Out of MPPT Zone .....	58
13.6	Altitude Derating Curve .....	59
13.7	Internal Circuit Diagram .....	59
<b>14.0</b>	<b>Accessory Options .....</b>	<b>60</b>
14.1	Fuse Bypass .....	60
14.2	SolrenView Monitoring .....	61
14.3	Shade Cover .....	61
14.4	AC & DC Disconnect Covers .....	63
<b>15.0</b>	<b>Appendices .....</b>	<b>64</b>
	Appendix A – PVI 23-28TL Datasheet .....	64
	Appendix B – String Sizing Tool.....	64
	Appendix C – Contact Information .....	64
	Appendix D – Authorized Distributors.....	64
	Appendix E – UL 1741 / UL 1699B/ IEEE 1547 / CSA 22.2#107.1 Authorization to Mark.....	65

## 1.0 Introduction

The PVI 23TL and 28TL are commercial, dual MPPT, three-phase utility-interactive, transformerless PV inverters designed to be interconnected to the electric utility grid. The inverter is listed for use with ungrounded PV arrays only. By following this manual, the inverter can be installed and operated safely. This installation guide is used as a reference for commissioning and as a guideline on how to use the inverter most effectively.

This inverter is a transformerless type without galvanic isolation. Therefore, the inverter may only be operated with ungrounded PV arrays. Furthermore, the PV array must be installed in accordance with NEC 690.35 (Ungrounded Photovoltaic Power Systems) and local regulations for ungrounded PV arrays. Additionally, the PV array (PV modules and cabling) must have protective insulation and the PV modules used must be suitable for use with this inverter.

The PVI 23-28TL includes key product protection functions, such as:

- Anti-Islanding Protection
- DC Arc-fault Circuit Interruption
- Protection Against Reverse Polarity
- Short Circuit Protection
- Monitoring DC Input Insulation Against Ground
- Monitoring AC Output Voltage and Frequency
- Monitoring Leakage Current Against Ground (GFCI)
- Monitoring DC Injection from AC Output
- DC Input and AC Output Over-voltage Protection
- DC Input Over-current Protection
- Monitoring Ambient Temperature
- Monitoring IGBT Module Temperature
- Wide-range Frequency and Voltage Support

The inverter is suitable for use indoors and outdoors. It meets the requirements of ANSI/NFPA 70, NEC690.5, UL 1741, IEEE 1547, and IEEE 1547.1 for the parallel operation of power generation plants on low-voltage networks of regional electrical utility companies.

The function of the Anti-Islanding protection complies with UL 1741/IEEE 1547 specifications. The Anti-Islanding function guarantees secure disconnection in the case of circuit isolation or interruptions in power supply while also protecting against isolated operation.

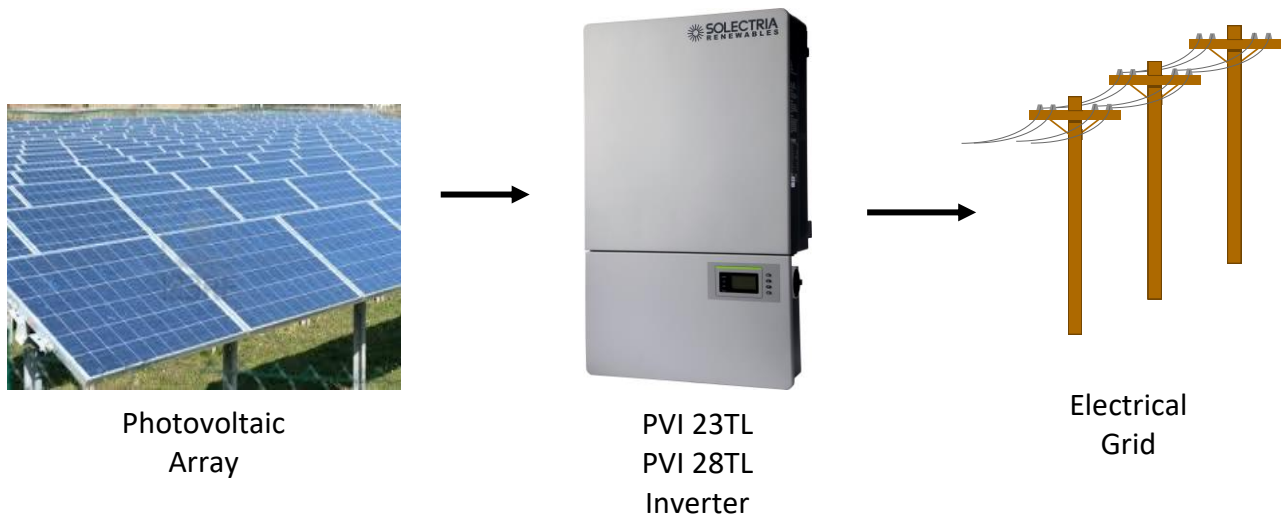
A DC arc-fault circuit interruption is integrated into the PVI 23-28TL inverter and complies with the requirement of a Type 1 device in the UL 1699B standard.



Feeding power back to the grid involves the conversion of DC voltage from the PV array to grid compatible AC voltage by inverting DC to AC. This unit feeds power into a standard, three-phase commercial, industrial, institutional, or electrical utility facility's electrical system which is connected to the electrical grid.

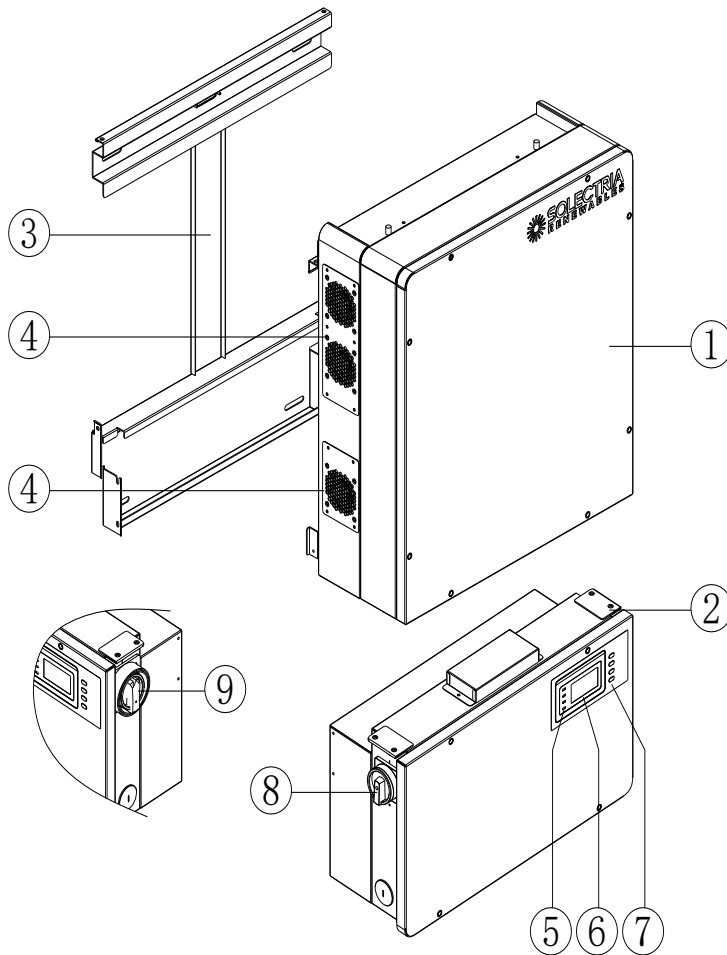
If the PV system and inverter are providing the same amount of electrical power that the facility is using, then no power is taken from or fed into the utility grid. If the facility is using more power than the PV system is providing, then the utility grid provides the balance of power. If the facility is using less power than the PV system is generating, then the excess is fed into the utility grid.

Be sure to follow local regulations regarding net metering and interconnection in your local area. Note that some utilities need to change their kWh meter for proper net metering measurement and billing.



**Figure 1.1 – Grid-Tied Inverter Application**

## 1.1 PVI 23-28TL Inverter Enclosure



### ① Inverter Main Housing

Does not contain any serviceable parts; opening this section voids the inverter warranty.

### ② Wiring Box

For customer's AC and DC wire connections.

### ③ Mounting Bracket

### ④ Cooling Fans

### ⑤ LED Indicators

There are four LED indicators used to signal the operating status of the inverter.

### ⑥ LCD

The LCD displays all measured values and parameters.

### ⑦ Control Keys

There are 4 control keys, to switch between display menus and to configure the settings of the inverter.

### ⑧ DC Disconnect Switch

Built-in, lockable disconnect switch used to disconnect the DC input to the inverter.

### ⑨ AC Disconnect Switch

Built-in, lockable disconnect switch used to disconnect the AC output from the PV inverter.

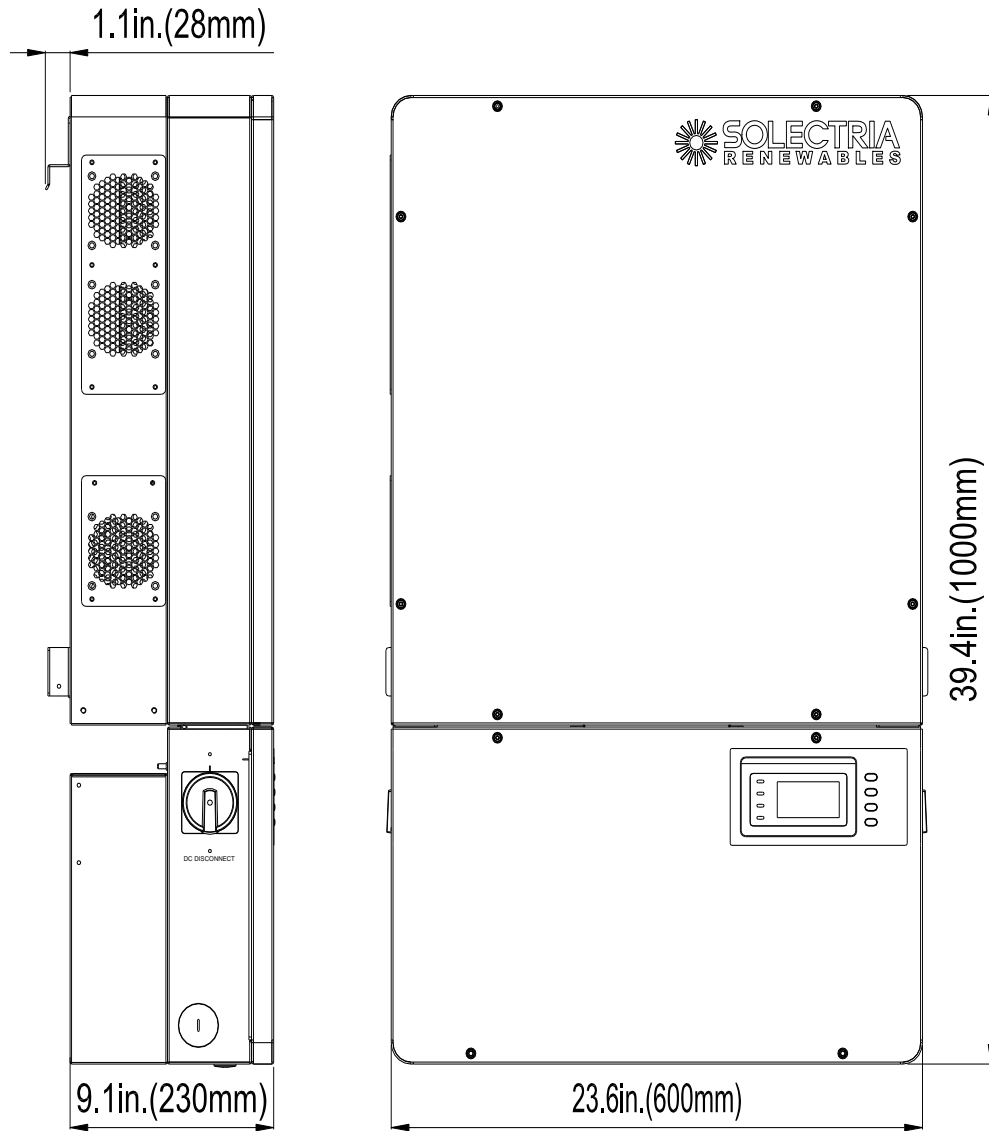
Figure 1.2 – PVI 23TL Inverter Interface

## 1.2 PVI 23-28TL Inverter Main Parts and Accessories

Every PVI 23-28TL inverter comes equipped with the following:

Item	Quantity	Description
Inverter Main Housing	1	The upper section of the inverter. It contains no serviceable parts and the opening of this section voids the inverter warranty.
Wiring Box	1	The lower section of the inverter, intended for customer's AC and DC wire connections.
Mounting Bracket	1	Used to mount an inverter to the wall.
Installation and Operation Manual	1	Please read carefully before attempting to install the inverter.
M8 Expansion Tubes	8	Used for mounting bracket installation.
M8*25 Assembly Bolt	8	Used for mounting bracket installation.
M6*16 Screw	6	Four are used to connect the main housing of the inverter to the wiring box (2 are spares).
M5*10 Screw	8	Six for mounting the inverter to the mounting bracket, one for external ground connection (one spare).
M3*8 Screw	2	Secures the partition plate between the signal wires and the AC power wires.
M5 Flange Nut	2	One for internal ground stud connection (one spare).
M10 Lifting Eye Nut	2	Used for lifting the main housing.
OT Type Terminal	2	Can be used for grounding connections.
Pre-insulated End Ferrule for DC Connections	20	16 for DC input cables (4 are spares).
RJ45 Connector	4	For Ethernet communication (2 are spares).
5-Pin Connector	1	For RS-485 communication.
3-Pin Connector	1	For dry contact communication.
Partition Plate	1	The partition between the signal wire and AC power cables.

**Table 1.1 – Inverter Main Parts and Accessories**



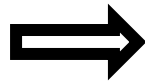
**Figure 1.3 – PVI 23-28TL Inverter Dimensions**

## 2.0 Site Preparation and Inverter Placement

The inverter is comprised of a NEMA 4 enclosure, containing electrical and electronic components as well as AC and DC integrated disconnects.



**NOTE:** If the inverter is mounted outside, ensure that the wiring box remains closed during the installation process until access to the box is needed. This precaution will help to avoid damage due to rain, snow, or condensation. Damage to the inverter caused during the installation process will void the warranty. The inverter main housing cover must remain on at all times.



**NOTE:** It is recommended to store the inverter indoors before installation. If the inverter is to be stored outdoors before being installed and commissioned, care must be taken to avoid condensation inside the unit.

### 2.1 Criteria for Device Mounting

- Because the power electronics are within the rainproof enclosure, the inverter can be mounted outdoors.
- The maximum life for the inverter is achieved by mounting the unit in a clean, dry, and cool location.
- For optimal electrical system efficiency, use the shortest possible AC and DC cables but use the maximum allowable cable size.
- Install the inverter in an accessible location following local electric codes for enclosure proximity to other equipment.
- Although the inverter is designed to function at full power continuously up to 45°C ambient temperature, for optimal inverter life and performance do not mount the inverter in direct sunlight, especially in hot climates. If the unit must be mounted in direct sunlight, a sun-shield is recommended but not required. It is recommended that the inverter is mounted on the north side of buildings or on the north side of a ground mount PV array.



**WARNING:** Be sure to verify load capacity of wall or mounting area where the inverter will be mounted.

Inverter Model	Weight
PVI 23-28TL	122lbs (55kg)

**Table 2.1 – Inverter Weight**

- The ambient temperature must be between -25°C and +45°C for full power and continuous operation. The inverter will automatically reduce power or may shut down to protect itself if ambient air temperature is outside the normal operating range.
- The National Electrical Code (NEC) requires the inverter to be connected to a dedicated circuit with no other outlets or devices connected to this circuit (see NEC Articles 690 and 705). The NEC also imposes limitations on the size of the inverter and the manner in which it is connected to the utility grid (see NEC Articles 690 and 705 for guidance within the US).
- The cooling air exhausts are at the right of the inverter. As the air intake is on the left side of the inverter section of the unit, there should be at least 12 inches of clear space at the left of the enclosure. Air should be able to flow all around the unit for proper ventilation.
- It is also recommended to have at least 24 inches of clearance at the bottom side for the Inverter LCD to be at eye level (see Figure 3.3 for details).
- A minimum distance of 12 inches must be clear above the inverter for ventilation.
- If you are installing the inverter in a utility vault or electrical closet, the air circulation must be sufficient for heat dissipation. Provide external ventilation to maintain an ambient condition of 45°C or less for full power. The ambient temperature should be kept as low as possible at all times for optimal inverter operation and life.

## 3.0 Inverter Mounting



**WARNING:** Any lifting or moving of the inverter requires *at least* two people. Lifting of the crate/pallet requires *at least* three people.

### 3.1 Checking for Shipping Damage

The inverter is thoroughly checked and tested rigorously before it is shipped. Although the shipping container is adequately designed to protect the inverter during shipment, the product may be damaged by poor handling, trucking, or transfer station activity.

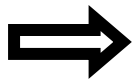
Please inspect the inverter thoroughly after it is delivered. If any damage is present, immediately notify the shipping company to make a claim. If there is any question about potential shipping damage, contact Solectria Renewables but do not remove the unit from pallet/package. Photos of the damage would also be helpful in documenting potential shipping damage. If the unit is to be returned, an RMA number must be obtained from Solectria Renewables prior to shipping the unit back.

### 3.2 Unpacking and Moving the Inverter into Place

It is recommended to keep the inverter secured in its box and move it as close as possible to the final location prior to removing it.



**WARNING:** Any lifting or moving of the inverter, without the aid of equipment, should be performed by *at least* two people.



**NOTE:** Failure to follow these lifting guidelines may cause structural damage to the inverter and void the warranty.



**WARNING:** Do not install the inverter over combustible surfaces or materials.



**WARNING:** Severe injury or death could occur if the mounting fails and the inverter falls and lands on a person.



**NOTE:** The weight of the inverter will exert an added load to the wall or area where it is to be mounted. Be sure to verify proper load capacity of mounting area.

### 3.3 Inverter Positioning and Mounting

The Inverter can be mounted vertically or with a 15°-90° horizontal angle, as shown in Figure 3.1a and 3.1b below.



The shade cover option must be purchased and installed for any installation angles of 75° or less.

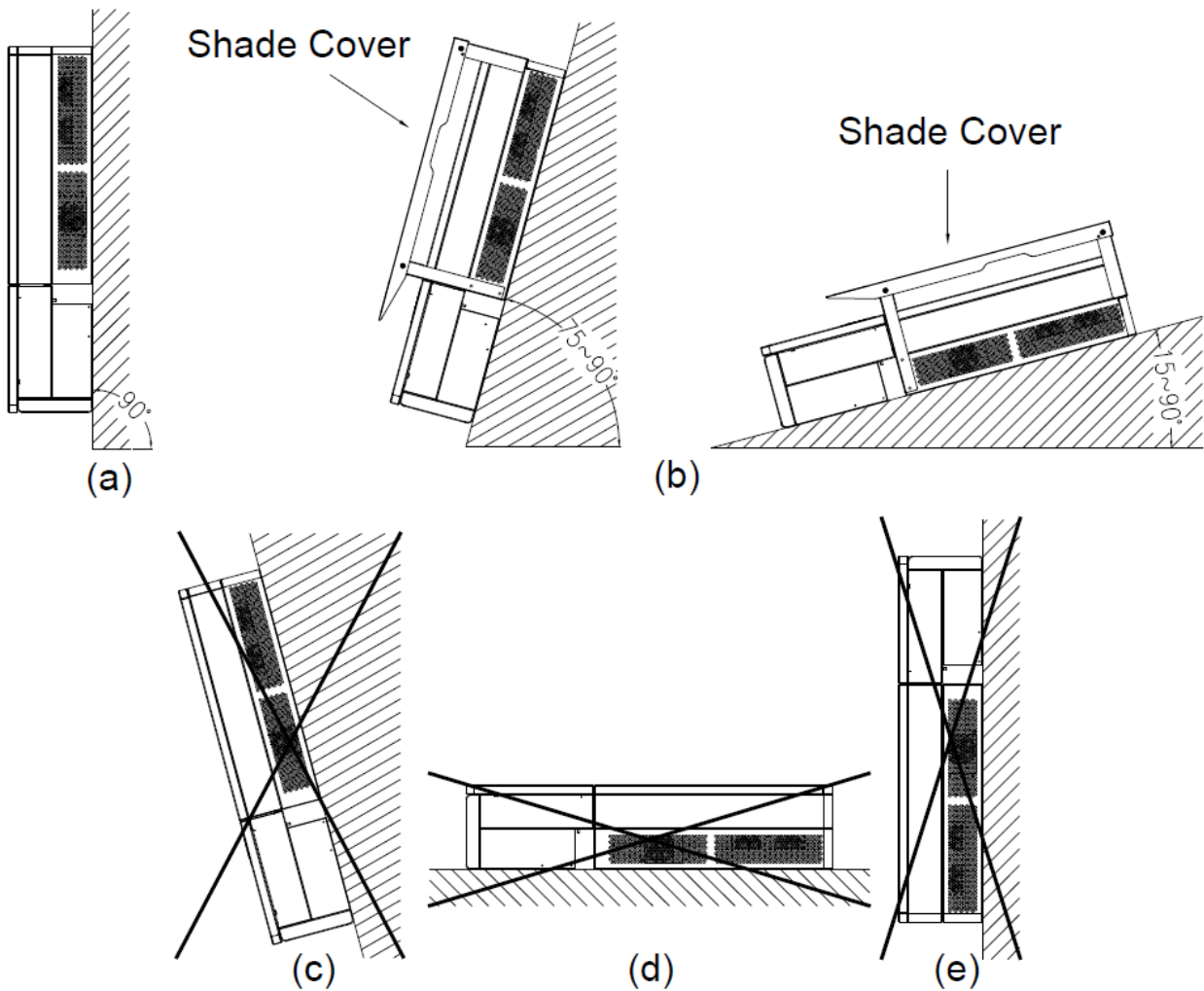


Figure 3.1a – Allowable Inverter Mounting



**WARNING:** Do not install the inverter tilted forward, lying on its back, or upside down as shown in Figure 3.1 c, d and e.



**WARNING:** Shade covers are required for inverters installed at angles 75° or less.



### 3.3.1 Wall Mounting

The minimum distances that should be met for wall mounting are shown in Figure 3.2 below.

- For adequate cooling, there should be a minimum of  $\geq 20$  inches of space available between two adjacently mounted inverters.
- A minimum of 12 inches from the left side and 12 inches from the top are needed for adequate access and cooling.
- A distance of 24 inches from the bottom is recommended for the inverter's LCD to be at eye level. If needed, this distance can be lowered to 10 inches.

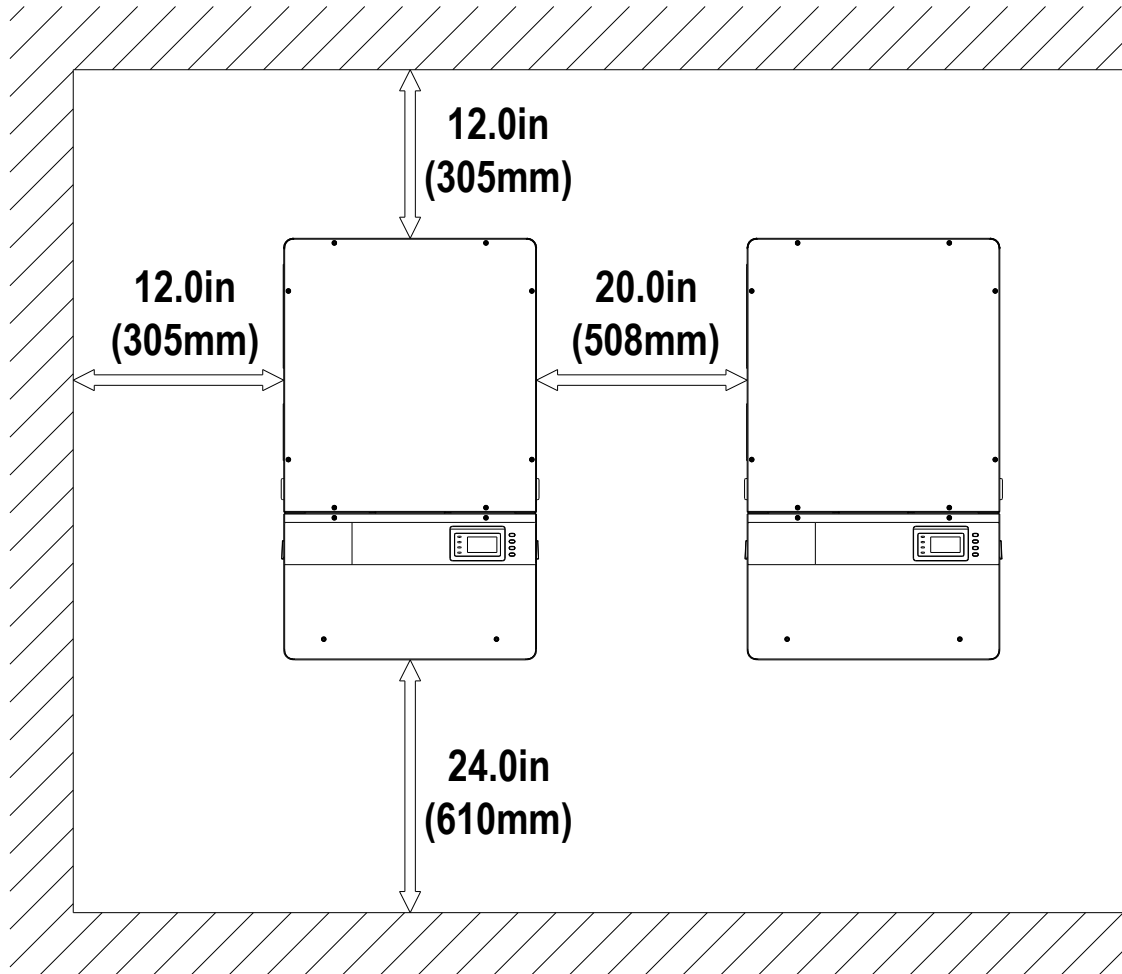


Figure 3.2 – Wall Mounting Clearance Requirements

### 3.3.2 Wall Mounting/Mounting Bracket Clearance

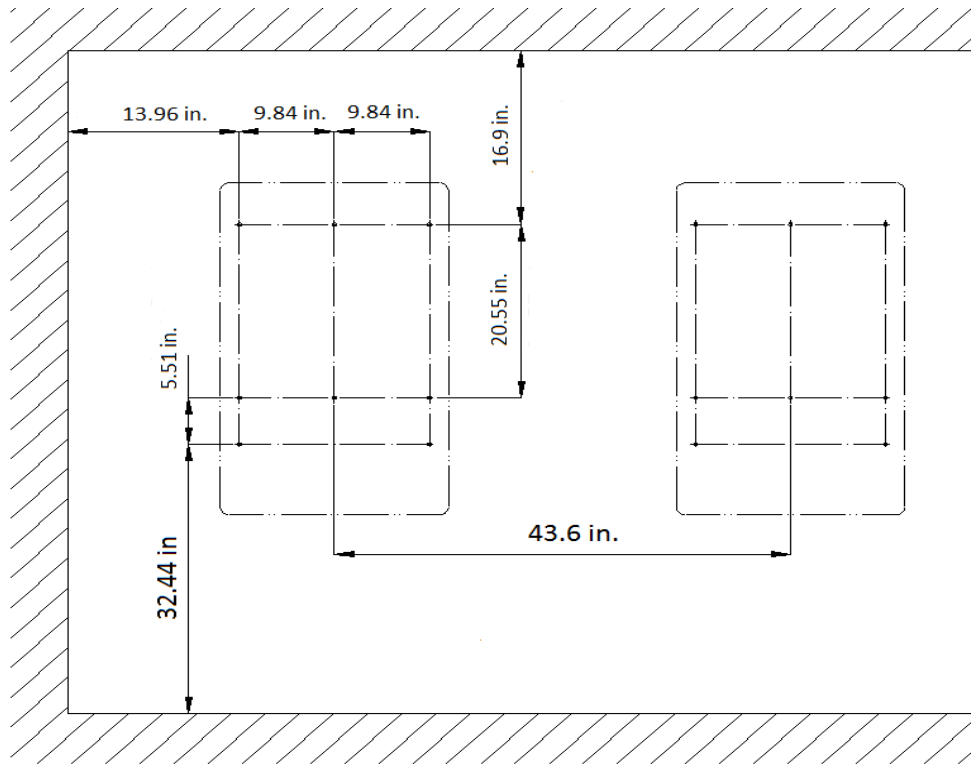


Figure 3.3 – Wall Mounting Clearance Requirements of Mounting Bracket

### 3.3.3 Pillar Mounting

The minimum inverter mounting dimensions on a pillar are shown in Figure 3.4 below.

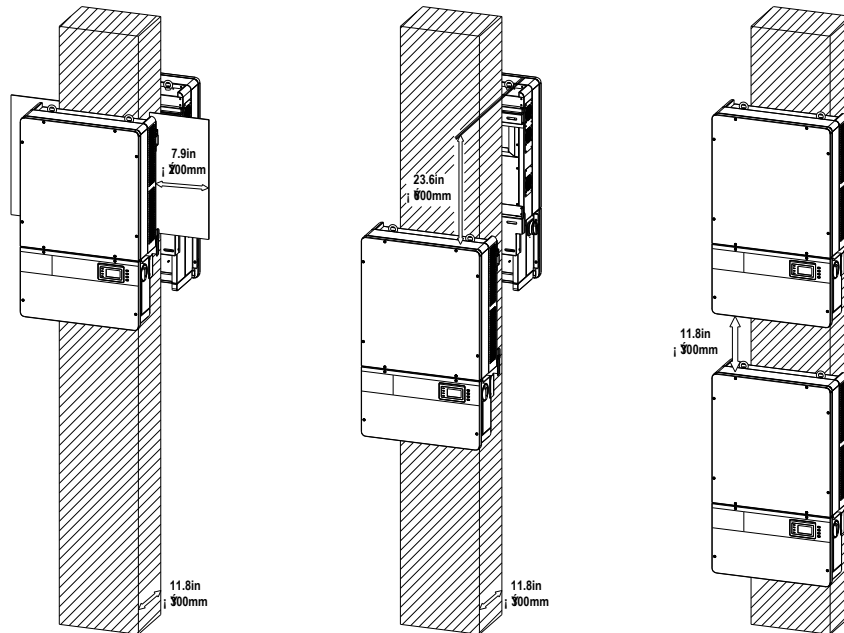


Figure 3.4 – Inverter Pillar Mounting Dimensions

### 3.4 Installing the Mounting Bracket

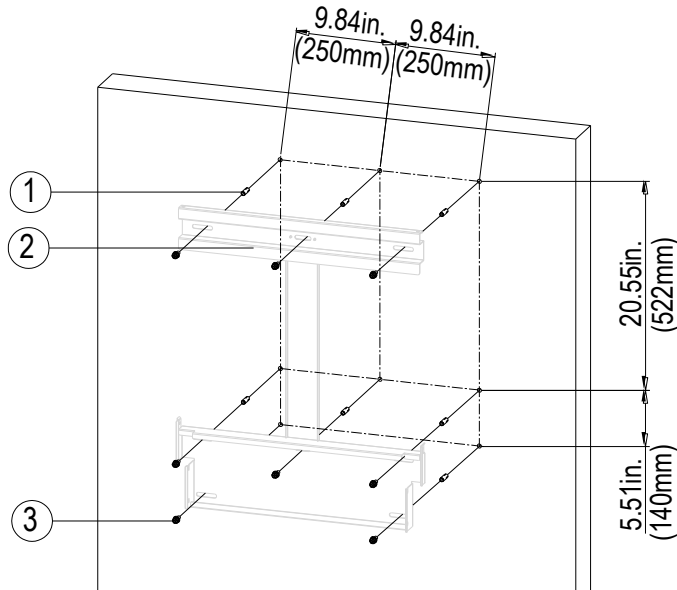
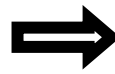


Figure 3.5 – Inverter Wall Bracket Mounting



**NOTE:** Always use all (8) mounting plate fasteners.

1. Mark the 8 holes on the load-bearing surface using the available mounting bracket as a template (see Figure 3.5).
2. Drill 8 holes with a 13/32-inch drill bit and install eight “M8 expansion tubes” (available in accessory box).
3. Secure the bracket to the wall using eight M8X25 bolts (available in accessory box). See Figure 3.5.

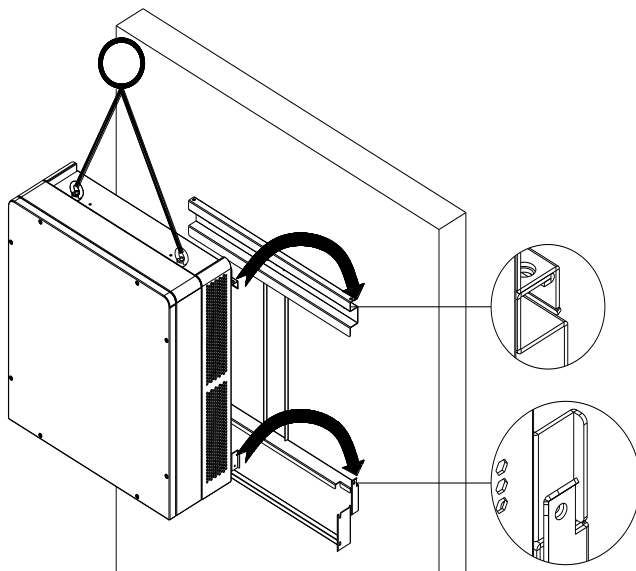
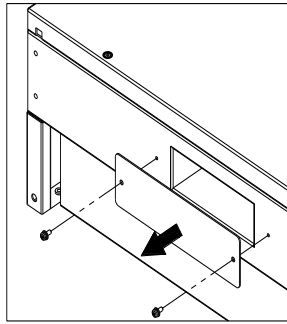


Figure 3.6 – Inverter Main Housing Mounting

4. (Option 1) Lift mounting: Attach both lifting eye bolts (available in accessory box) to the inverter housing box. Use a sling rope or bar passed through both eye bolts to mount the inverter to the bracket.

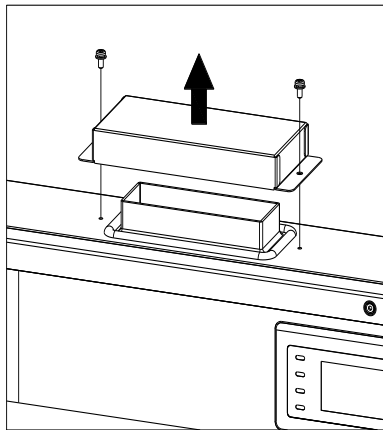
(Option 2) Manual lift: Two people lift the inverter from the bottom and manually mount the inverter to the bracket.

5. Carefully secure the main housing of the inverter onto the bracket.



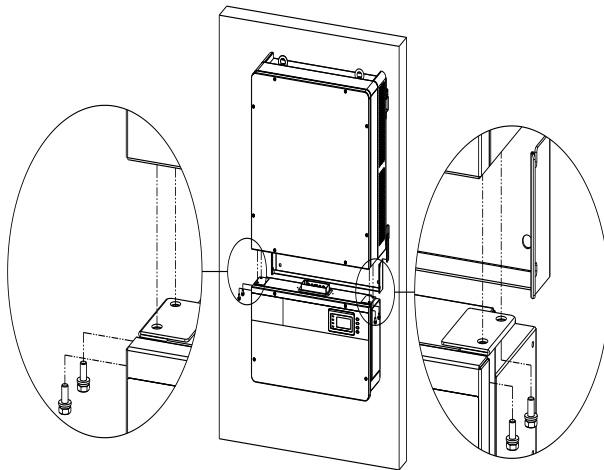
**Figure 3.7 – Remove Cover Plate of Main Housing**

6. Using a #2 Philips screw driver, remove cover plate on the bottom of main housing.



**Figure 3.8 – Remove Cover of Wiring Box**

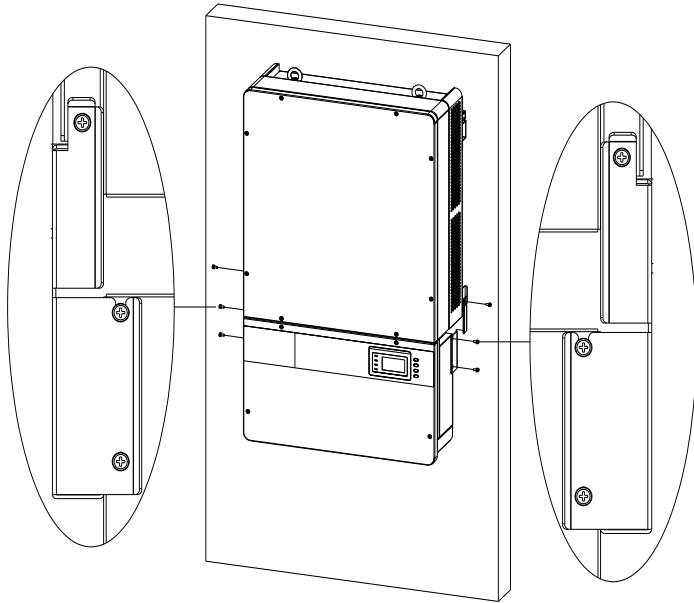
7. Using a #2 Philips screw driver, remove cover of wiring box and keep the cover (it can be re-secured later onto the enclosure).



**Figure 3.9 – Connecting the Wire Box to the Main Housing**

8. Connect the wiring box to the main housing using four M6\*16 screws (available in accessory box).

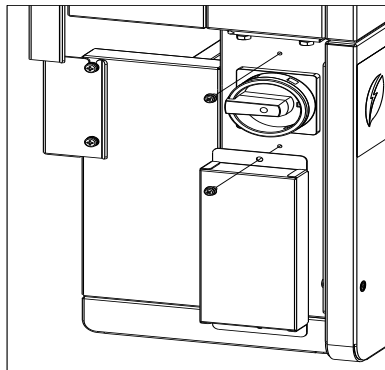
Torque = 25in-lbs



9. Connect the main housing and wiring box to the mounting bracket using a #2 Philips screwdriver and six M5\*10 bolts (available in accessory box).

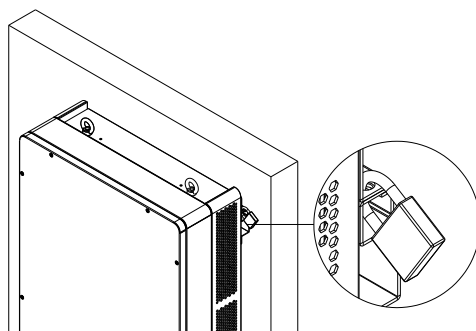
Torque = 14in-lbs

**Figure 3.10 – Fasten the Main Housing and Wiring Box onto the Bracket**



10. The previously removed cover box can be reattached to the left side of the wiring box (available in accessory box).

**Figure 3.11 – Attaching the Cover Board**



**Figure 3.12 – Installing an Anti-theft Padlock**

11. An anti-theft padlock can be installed as shown in the image to the left (padlock not available in accessory box).

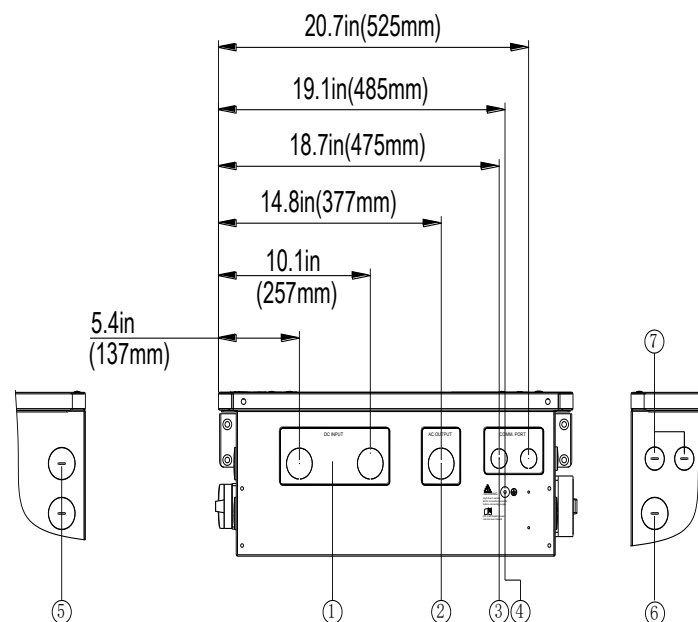
## 4.0 Grounding Connections



**WARNING:** All electrical installations must be performed in accordance with any applicable local electrical codes, and must be done by electrically qualified personnel. AC and DC grounding connections should only be made directly to the terminals within the wiring box.

### 4.1 Inverter Knockouts

The inverter comes equipped with identified knockouts at the bottom and the side of the electrical wiring box. Adding additional knockouts will void the inverters warranty.



1. Knockout for DC input cable, 1-1/4inch
2. Knockout for AC output cable, 1-1/4inch
3. Knockout for communication cable, 3/4inch
4. External ground connection point
5. Side knockout for DC input cable, 1-1/4inch
6. Side knockout for AC output cable, 1-1/4inch
7. Side knockout for communication cable, 3/4inch

**Figure 4.1 – Knockouts and External Ground Connection**

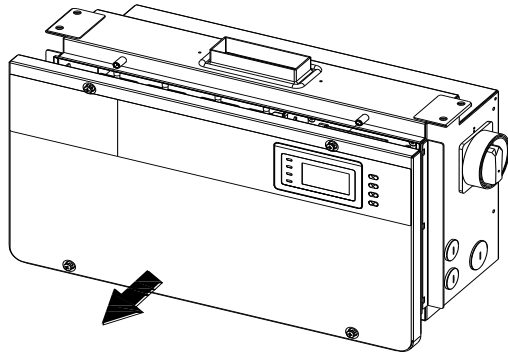


Figure 4.2 Removing the wiring box cover

**Removing/Replacing the Wire Box Cover:**

(1) Use a #3 Phillips screwdriver to remove the 4 screws on the wiring box and pull cover straight off the box. Do not twist or slide the cover while removing.

(2) To replace the cover use a #3 Phillips screwdriver to replace the 4 screws on the cover.

**INSTRUCTION:**

Always use a hand tool (e.g. Screwdriver or T-handle, #3 Phillips), never a power tool or any other type of screwdriver. It is also important to hold the cover in alignment with balanced force across the cover, not weighted toward any edge. Partially engage all four screws to the threaded inserts a few rotations before tightening any one screw. This is important to maintain alignment and avoid thread damage. When all four screws are engaged torque to 20 in-lbs (2.2Nm).

**4.2 DC/AC Grounding**

PVI 23-28TL inverters have a DC ground bar with four terminals that can be used to terminate the DC equipment ground, each terminal can accept a single copper conductor ranging from 6-10AWG (Torque = 14in-lbs). As shown in Figure 4.3 on the next page.

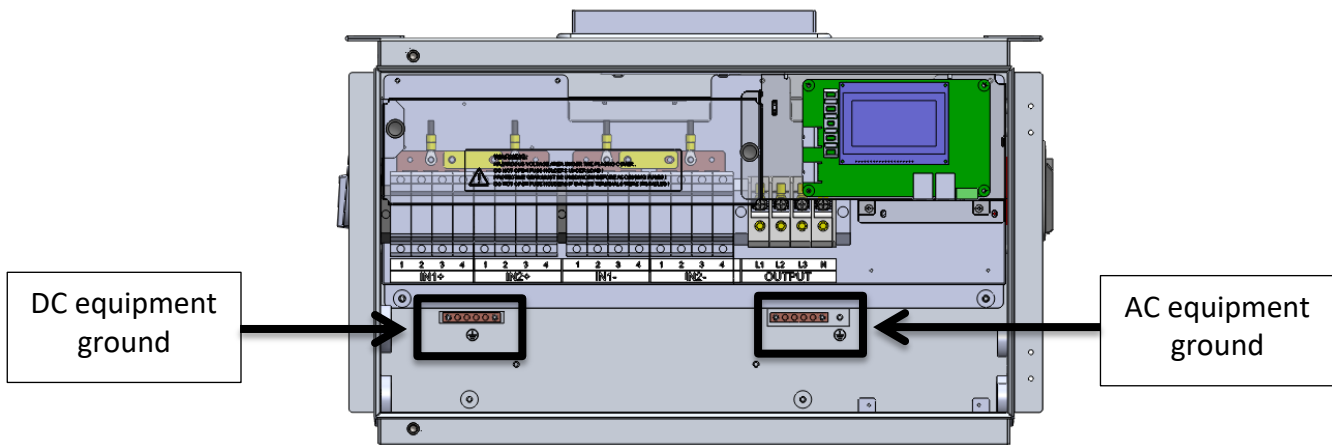


Figure 4.3 DC Equipment Ground

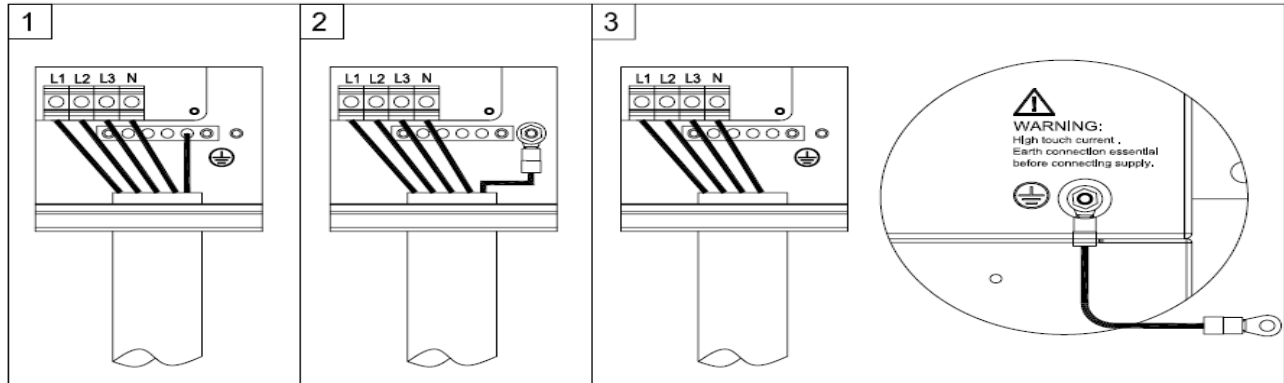
PVI 23-28TL inverters also have an AC ground bar with four terminals that can be used to terminate the AC ground. Each terminal can accept a single copper conductor ranging from 6-10AWG (Torque = 14 in-lbs), a stud that fits an M5 nut to terminate the AC system ground (Torque = 14in-lbs), and an external ground point (Torque 14in-lbs). The stud and external ground can accept a single copper conductor ranging from 8-10AWG.



**NOTE:** The lug for the stud is located in the accessory box.



**WARNING:** Install grounding conductors per local codes and standards.



**Figure 4.4 – AC Ground Wiring Connection**

## 5.0 DC Connections from the PV Array



**WARNING:** All wiring connections at the inverter must be performed with the building AC source circuit panel/breaker off and the PV module strings disconnected. AC and DC disconnect switches at the inverter must also remain off during termination.



**WARNING:** All electrical wiring must be done by electrically qualified personnel in accordance to local and national electrical code.



**WARNING:** Remove all fuses. Before connecting the DC conductors of the PV array to the inverter, verify and mark the polarity of the conductors. Verify the correct polarity and voltage before installing fuses.



**WARNING:** Before connecting the DC conductors of the PV array to the inverter fuse terminal or bypassing them, verify that the DC voltage is less than 1000VDC in all conditions. DC voltages over 1000VDC will damage the inverter. Configure the array such that the open circuit voltage will never exceed 1000VDC. *Warranty is void if more than 1000VDC is applied to the DC section of the inverter.*





**WARNING:** Fuses in the inverter must only be replaced with the same type and rated fuses as originally installed.



**WARNING:** The terminal is rated only for CU wire; using AL wire directly at the terminal will void the warranty. The use of AL wire must follow local code requirements for connecting AL wire to CU terminals.

## 5.1 DC Wiring

For DC wiring, 90°C PV copper conductors must be used. The inverter terminals are listed for 75 °C wire; see NEC 310.10 or the Canadian Electrical Code regarding the temperature ratings of wire and terminals. The conductor size shall not be smaller than the 75°C wire size based on the ampacities given in Table 310.16 of the NEC, ANSI/NFPA 70, and an additional derating factor of 125% as indicated by UL 1741.

A maximum of 16 total DC conductors (8 positive & 8 negative) can be connected and fused at 15Amps as shown in Figure 5.1 below.



**NOTE:** Verify that any wire size choices meet local codes.



**NOTE:** Always connect an equal number of wires to PV1 and PV2 connectors for dual MPPT zone operation. If an odd number of connections are required, we recommend setting the inverter to single (combined) MPPT zone. See Section 5.2 for a detailed explanation on the difference between operating in combined or independent MPPT modes.



**WARNING:** Strings must be balanced for optimum performance and AC output. When calculating DC/AC ratio sizing, perform calculations on the zone level unless you intend to combine MPPT. Maximum DC/AC oversizing ratio is 1.35 STC conditions of the modules. Each zone's maximum input power is 15.5 kW for PVI 23TL and 18.9kW for PVI 28TL. Note for any application that may experience higher than 1000 W/m<sup>2</sup> on a regular basis, a smaller DC/AC ratio is recommended. The maximum input current per zone must not exceed 25A for PVI 23TL and 29A for PVI 28TL. Failure to follow these guidelines will result in damage to the inverter and void your warranty.

The wiring box design has been updated (see “Gen III” below). For Generation I or II, please refer to the previous revision of this manual, which can be obtained electronically through the Solectria website.

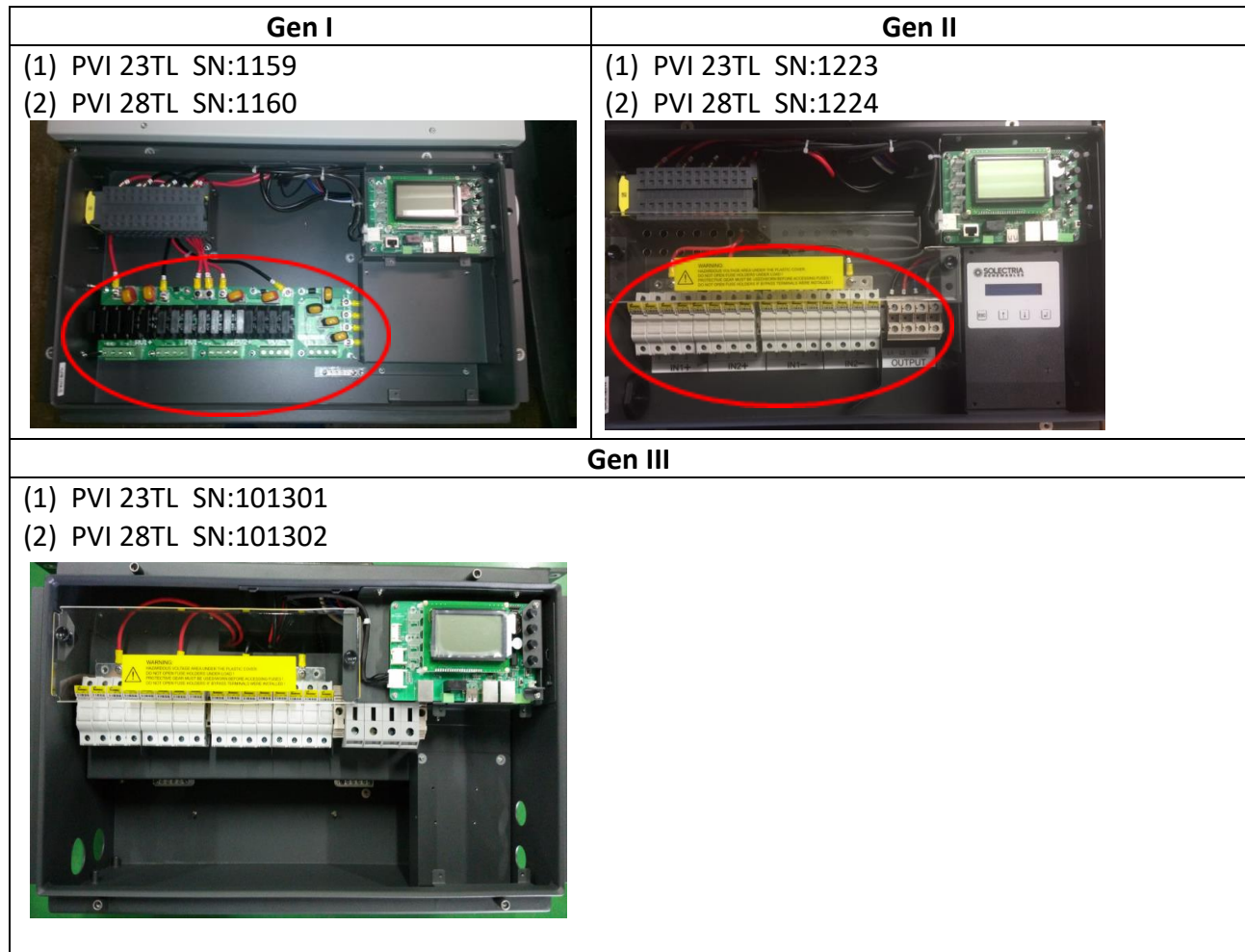


Figure 5.1 – Wiring Box Design Change

DC Inputs	Configuration	Max. DC Wire Size	Recommend PV Fuse	Conductors Torque (ALL)	Fuse Type
8 Inputs	Standard use of Integrated String Combiner Box	4AWG	12A/1000V for PVI 23-28TL	30in-lbs	PV Fuse
7 Inputs*	Standard use of Integrated String Combiner Box	4AWG	15A/1000V for PVI 23-28TL	30in-lbs	PV Fuse
6 Inputs	Standard use of Integrated String Combiner Box	4AWG	15A/1000V for PVI 23TL 20A/1000V for PVI 28TL	30in-lbs	PV Fuse
5 Inputs*	Standard use of Integrated String Combiner Box	4AWG	20A/1000V for PVI 23-28TL	30in-lbs	PV Fuse
4 Inputs	Standard use of Integrated String Combiner Box	4AWG	25A/1000V for PVI 23-28TL	30in-lbs	PV Fuse
2 Inputs Fuse Bypass	Two Inputs that Bypass Fuse Holder	2AWG	Fuse Bypass-option	50in-lbs	Fuse Bypass

Option					
1 Input* Fuse Bypass Option	One Input that Bypasses Fuse Holder and uses Combined MPPT Zones	2AWG	Fuse Bypass- option	50in-lbs	Fuse Bypass

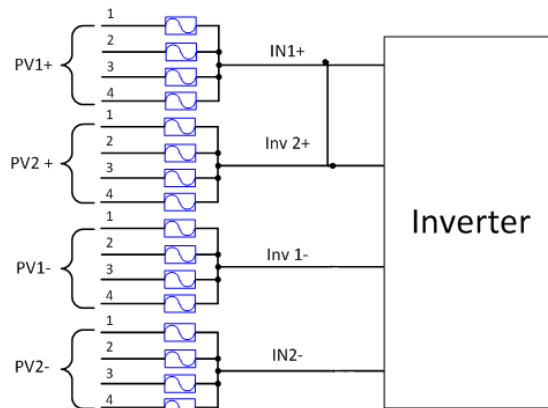
\*Consider combining MPPT zones for such configuration.

**Table 5.1 – DC Inputs and Configurations**

## 5.2 Dual Maximum Power Point Tracking

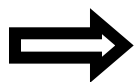
The inverter is designed with two separate MPP Trackers (Dual MPPT) which can operate independently or combined. The default is combined MPPT.

That means both MPP Trackers were combined to operate as one. This allows for the power to be evenly distributed between the two trackers such as applications of odd number of strings.



**Figure 5.2 – Two MPPTs Combined to Operate as One**

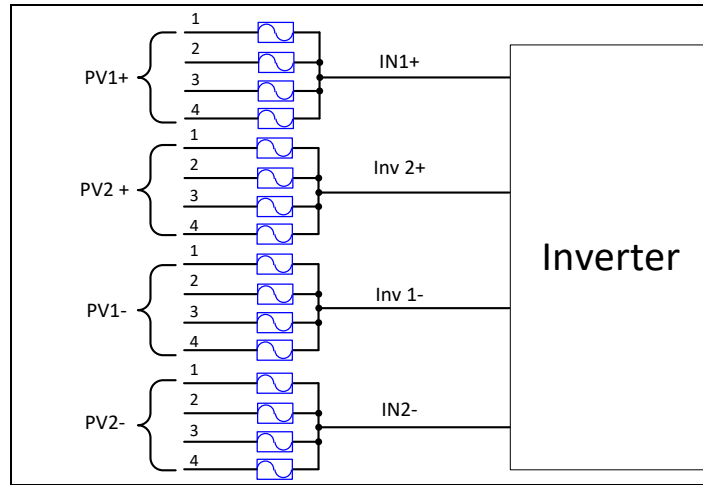
The second option is two MPP Trackers that operate separately, which can be very helpful for sites with shading. However, this also means that one must consider these two zones as two separate inverters and power must be balanced between the two MPPT zones.



**NOTE:** Always connect an equal number of wires to PV1 and PV2 connectors for dual MPPT zone operation. If an odd number of connections are required, we recommend setting the inverter to single (combined) MPPT zone.



**NOTE:** Connecting all of the inputs at zone “PV1” will result in only utilizing 50% of the inverter power.



**Figure 5.3 – Two MPPTs Operating Independently**

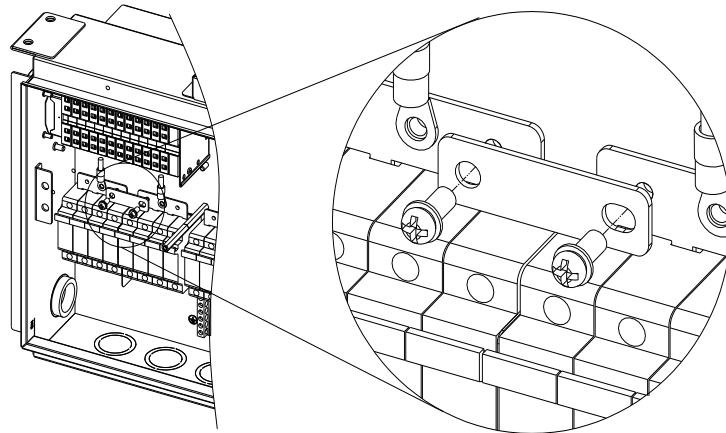


**WARNING:** Strings must be balanced for optimum performance and AC output. When calculating DC/AC ratio sizing, perform calculations on the zone level unless you intend to combine MPPTs.

### 5.2.1 Setting the Inverter to Operate with Two Independent MPPTs

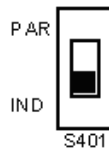
The two MPPT zones can be separated using the following steps:

1. Disconnect all AC and DC sources to the inverter.
2. Remove the Lexan cover of the wiring box.
3. Use a #2 Philips head screwdriver to remove the busbar that connects INV 1 + & INV 2+ at the top (see Figure 5.4 next page).

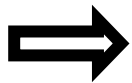


**Figure 5.4 – Busbar Connection Used for Single (Combined) MPPT Option Removed**

4. Set the S401 switch to Independent (IND) mode.



**Figure 5.5 – Switch Configuration for Two Individual (Dual) MPPT Zones**



**NOTE:** The S401 switch is located under the “Enter” control key inside of the wiring box.

Dual tracking MPPT might seem overwhelming at first, so contact Solectria Renewables at [support@solectria.com](mailto:support@solectria.com) if you have further questions.

### 5.3 Fuse Bypass OPT-FUSEBYPASS-PVI-23-28

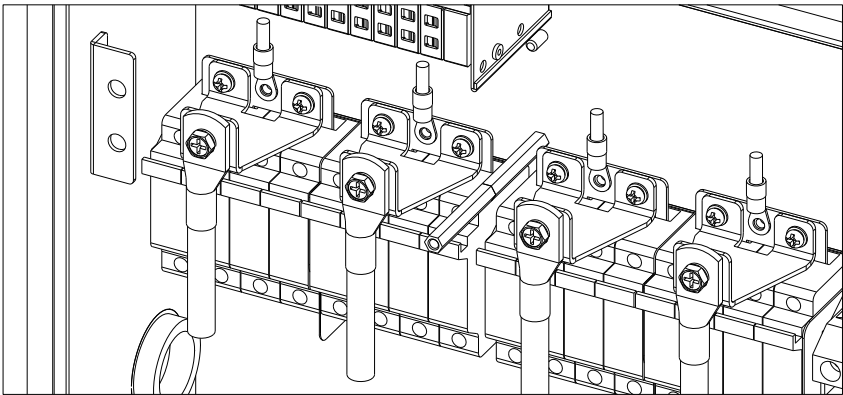
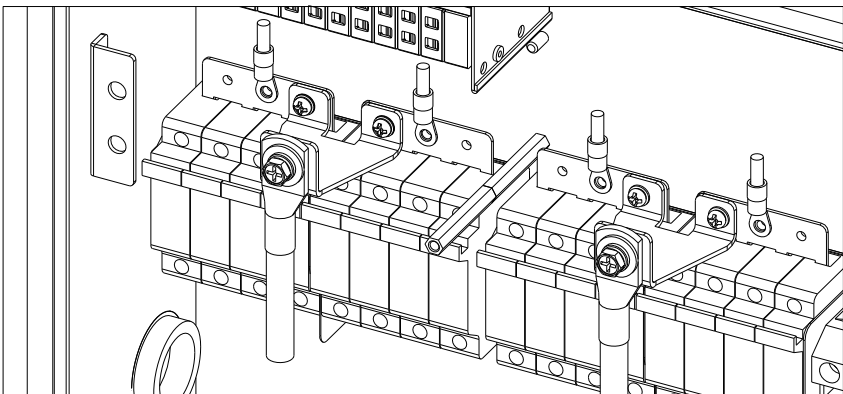
Fuse bypass is an option for customers that are interested in combining strings and fusing them outside the inverter. One can do so by ordering the fuse bypass accessory kit from Solectria Renewables. This allows for one to bypass the fuse holders.



**WARNING:** DC fuses inside the wiring box must be removed before any of the configurations in Table 5.2 are attempted.



**WARNING:** Fusing at an external combiner box is required for all of the connections in Table 5.2.

DC Inputs/MPPT Zones	Proper Wiring	S401 Switch	Wire
2 Inputs -2 Independent MPPT Zones		IND	2-4 AWG
1 Input - 1 Combined MPPT Zone		PAR	2AWG

**Table 5.2 – Internal String Combiner Bypass Option**

## 6.0 AC Connections at the Inverter

Both PVI 23TL and PVI 28TL 3-phase AC wiring is recommended to be installed with five conductors, one per phase along with a neutral and an AC equipment ground as per local requirements.



**WARNING:** The terminal is rated for CU and AL wire. Only Gen III AC terminal block is rated for CU and AL wire. Verify that you have a Gen III inverter before connecting AL wire.

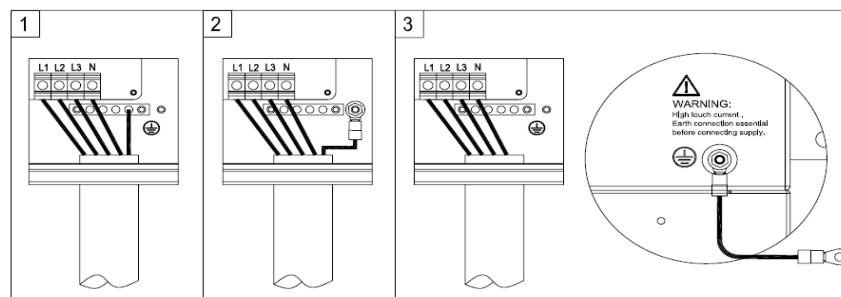
- The integrated disconnect switch terminals are listed for 75°C wire. See NEC 310.10 or the Canadian Electrical Code regarding the temperature ratings of wire and terminals.
- The conductor size shall not be smaller than the 75°C wire size based on the ampacities given in Table 310.16 of the NEC, ANSI/NFPA 70, and an additional derating factor of 125% as indicated by UL 1741. Temperature derating, voltage drop, and other considerations may dictate that larger than minimum wire sizes be used. Verify that wire size choices meet local codes and are properly sized to reduce voltage drop.

Inverter Model	AC Voltage	Number of Conductors	Max. AC Wire Size	Min. AC Wire Size	Torque	Max. AC Output Current	Recommended Breaker Size
PVI 23TL	480V	3 (1 per phase) plus neutral	1AWG	8AWG	30in-lbs	27.7A *	35A *
PVI 28TL	480V	3 (1 per phase) plus neutral	1AWG	8AWG	30in-lbs	33.7A *	45A *

\* Change is effective after S/N 1013011530001 and 1013021530001. For any prior S/N refer to Rev.E of this manual available on Solectria's website.

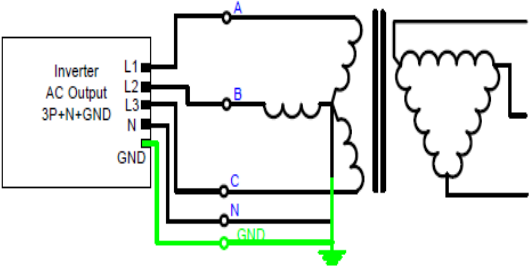
**Table 6.1 – AC Customer Connections and Interconnection Information**

The inverter includes an M5 stud for the connection of an AC Equipment Grounding Conductor (EGC). The stud can accept a single copper conductor ranging from 8-10AWG. AC EGC shall be sized per local code requirements. The AC EGC is connected to the stud via an M5 nut. A crimp lug is available in the accessory box provided (torque = 14 in-lbs).



**Figure 6.1 – AC Wire and Grounding Connections**

### 6.1 AC Interconnections to Grid

Description	Configuration	Inverter Compatibility
<p>4 Wire WYE (3 phase + Neutral +GND)</p>		<p>Compatible with 23TL Compatible with 28TL</p>
<p>Other Configurations</p>	<p>All other configurations not mentioned in this document, such as Corner Grounded Delta</p>	<p>Not compatible with 23TL Not compatible with 28TL</p>

**Table 6.2 – Allowable AC Interconnections to Grid**

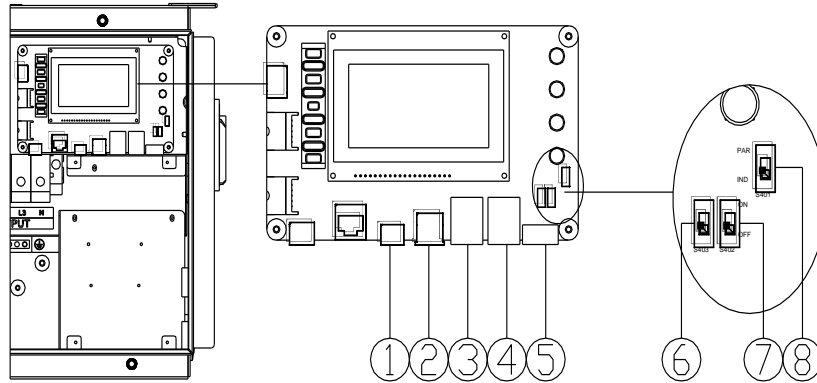


**WARNING:** Do not use power tools to reinstall the wiring box cover.



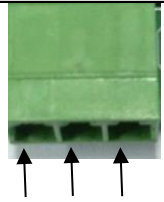
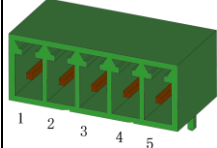

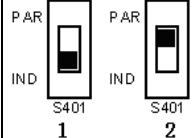
## 7.0 Communication Connections

The PVI 23-28TL inverters support industry standard Modbus RS-485 communications.



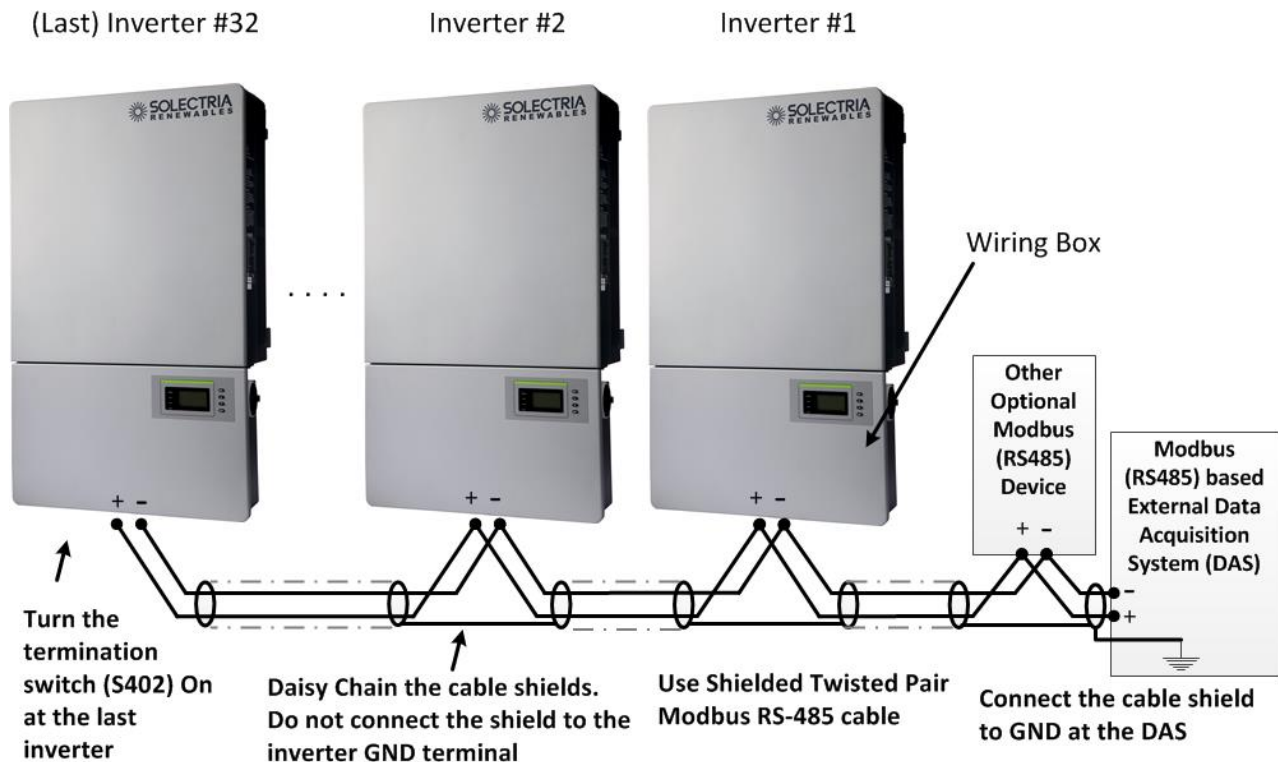
**Figure 7.1 - Communication/LCD and Component Locations Inside the Wiring Box**

**Table 7.1 - Communication Connections and Configuration Switches**

Item	Picture	Configuration description
1	 <p data-bbox="500 657 683 688">N.O. N.C. COM</p>	<p>P205 - Dry Contact Communication Port (3 Pin Connector)</p> <p>Please see section 7.3 Dry contact communication for more details.</p>
2		<p>P207 - USB port</p> <p>Reserved for factory use</p>
3		<p>P204 - Not Used</p>
4		<p>P203 - Not Used</p>
5		<p>P208 - Modbus (RS-485) connector</p> <p>1 - NC</p> <p>2 - NC</p> <p>3 - RS-485+</p> <p>4 - RS-485-</p> <p>5 - NC</p>
6		<p>S403 - Not Used</p>
7		<p>S402 - Selector switch for the 120Ω Modbus RS-485 termination resistor</p> <p>1 - Disable the RS-485 bus termination</p> <p>2 - Enable the RS-485 bus termination</p>
8		<p>S401 - Selector switch for setting the PV connection mode</p> <p>1 - Independent mode</p> <p>2 - Parallel mode</p> <p>See section 5.2 for more details</p>

## 7.1 Modbus (RS-485) Network Connections with External Monitoring Systems

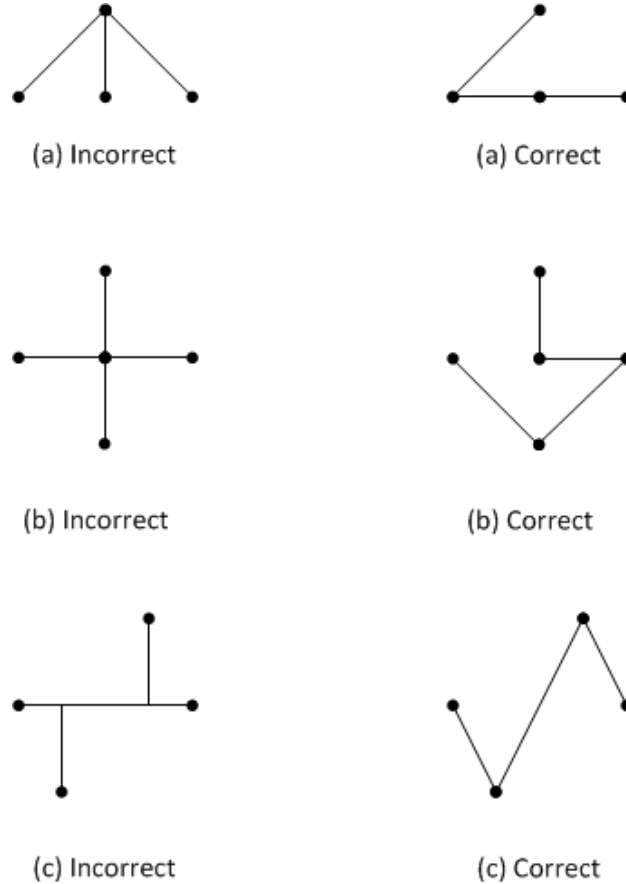
The PVI 23-28TL inverter can be connected to an external Data Acquisition System (DAS) via Modbus (RS-485) connection as shown in figure 7.2.



**Figure 7.2 - PVI 23-28TL Inverters in a Modbus (RS-485) Daisy Chain Connected to an External DAS**

- When connected to an external Data Acquisition System (DAS), Solectria PVI 23-28TL inverters support up to 32 inverters/devices on the Modbus (RS-485) daisy chain. The Inverter Modbus IDs are configurable from 1 to 128.
- Solectria recommends that the Modbus (RS-485) daisy chain for PVI 23-28TL inverters is limited to a maximum length of 1600 ft. (500m).
- Care must be taken when daisy chaining the inverters as shown above, utilizing a Shielded Twisted Pair Modbus cable such as Belden 9841.
- The shield continuity should be maintained for the entire length of the daisy chain and should only be connected to ground (GND) at the Data Acquisition System (DAS). The shield should not be connected to any of the inverters to prevent any possible ground loops.
- It is important to terminate the Modbus (RS-485) bus correctly to minimize any noise and reflections. The bus should be terminated at the source (the DAS) and at the last Modbus device in the daisy chain, typically an inverter. The PVI 23-28TL Modbus termination is turned on by flipping switch S402 to the ON position as shown in Table 7.1 should always be left in the off position except for the last inverter in the daisy chain.

- Star or T Modbus (RS-485) network topologies should always be avoided. See Figure 7.3.



**Figure 7.3**

It is important to daisy chain the inverter Modbus (RS-485) connections to minimize noise and bus reflections. Any network topologies shown to the left should be avoided. Equivalent daisy chain topologies shown to the right should be used instead.

**Connecting External DAS Modbus (RS-485) Network to the PVI 23-28TL Inverter:**

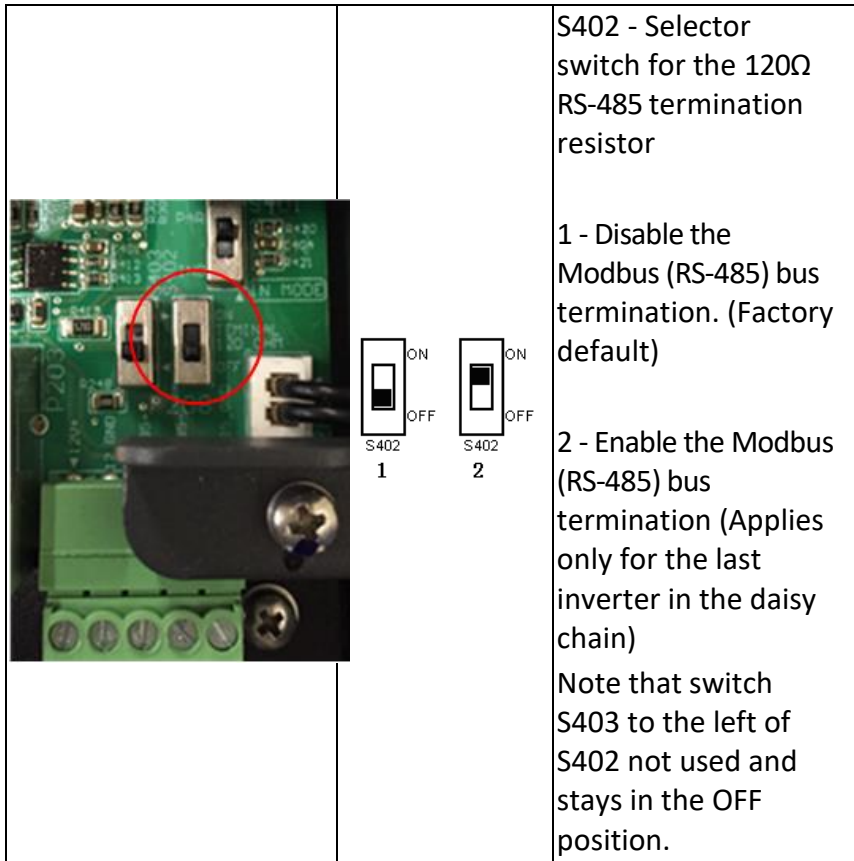


**Warning:** Risk of Electric Shock.

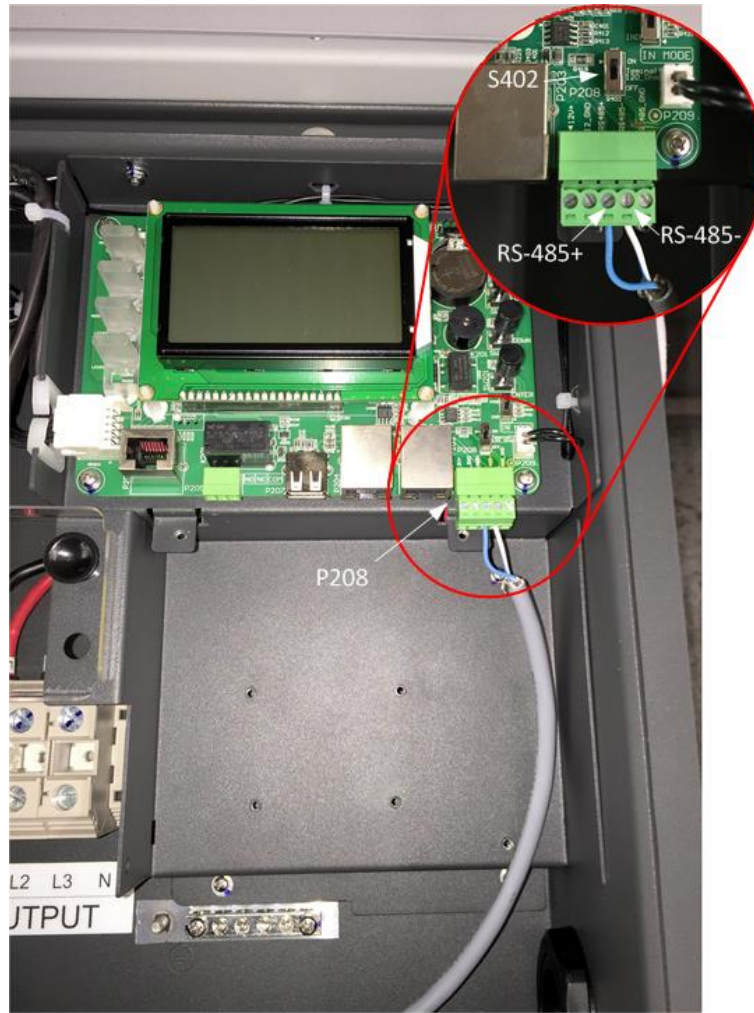
Make sure all DC and AC power to the unit has been disconnected before opening the inverter wiring box and make sure hazardous high voltage and energy inside the equipment has been discharged.

1. Open the inverter wiring box.
2. Bring the cable into wiring box through knockout holes at the bottom.
3. Connect the Modbus (RS-485) wires to the green Phoenix connector (P208) ensuring correct polarity and using a twisted pair in the shielded twisted pair cable.

4. If the inverter is the **last** Modbus device in the daisy chain, make sure the Modbus termination switch S402 is in the ON position (Up towards the LCD) enabling Modbus termination. Do **not** turn the switch to the ON position in any other inverters in the daisy chain.



**Figure 7.4 - The Modbus (RS485) Termination Switch (S402) Location and Settings on the LCD/Communication Board.**



**Figure 7.5**

The above image shows the Modbus (RS-485) cable connection where the Modbus daisy chain ends. Notice how the cable shield is not landed inside the inverter. The Modbus termination switch (S402) is in the on position.

5. **IMPORTANT:** The cable shield should only be connected to ground (GND) at the external DAS. Do not connect the shield to any of the inverters

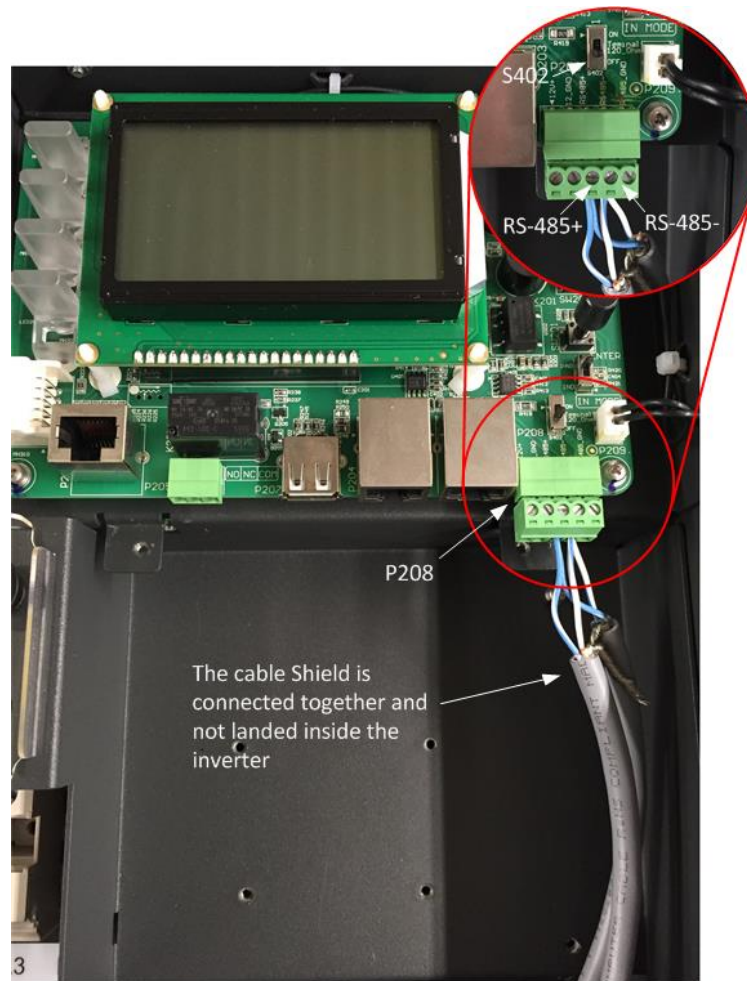


Figure 7.6

Notice how the cable shield is daisy chained together and not landed inside the inverter. S402 is in the OFF position, or down towards the Phoenix connector when the inverter is in the middle of the daisy chain.



**Warning:** Risk of Electric Shock.

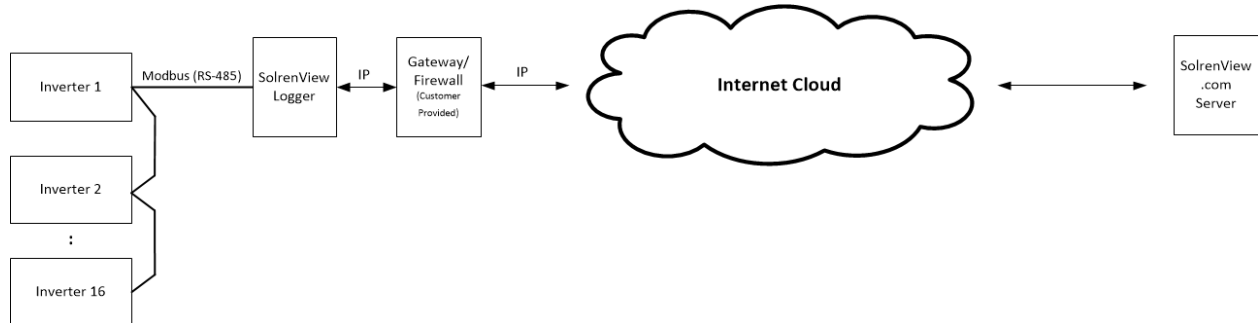
Make sure all shield wires are properly secured and insulated to prevent shorting to any other components inside the inverter.

6. Close the wiring box.
7. Reconnect AC and DC power and turn the inverter on when it is safe.
8. Configure the Inverter Modbus ID and Baud rate.

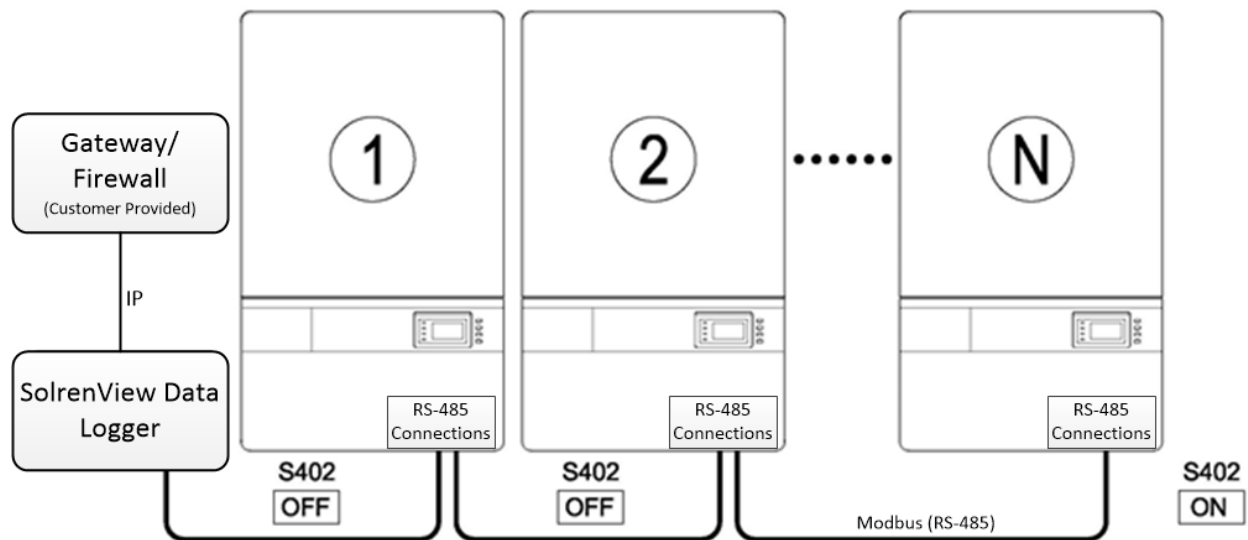
## 7.2 Connecting TL Inverters using SolrenView Monitoring Option

Solectria offers SolrenView monitoring as an option for the PVI 23-28TL inverters. In Gen III PVI 23-28TL inverters, SolrenView hardware is no longer an integrated option, only external. This option (SRV-LCD-3PTL-OUTDOOR) includes the SolrenView data logger which comes in an outdoor rated enclosure. The SolrenView logger is used to connect the TL inverters to the Solectria SolrenView web-based monitoring site.

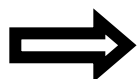
In Gen III the SolrenView gateway cannot be factory installed inside of the inverter.



**Figure 7.7 – High Level Block Diagram of the SolrenView Data Acquisition Infrastructure**



**Figure 7.8 – Multiple Inverters with SolrenView Data Logger**

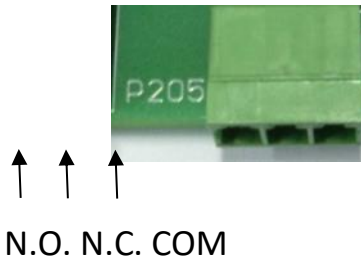


**NOTE:** The SolrenView data logger in Figure 7.8 is installed next to the first inverter. This is a typical installation.



### 7.3 Dry Contact Communication

The inverter features an alarm function that opens or closes a dry contact on the communication board. (available both as contact normally open – N.O. – and as contact normally closed – N.C.), as shown below:



**Figure 7.9 - Dry Contact Communication Port**

The voltage and current rating of the dry contact shown in the following table must not be exceeded under any circumstances.

**Table 7.2 - Dry Contact Rating**

	Voltage	Current
AC	Maximum 277 V	Maximum 3 A
DC	Maximum 30 V	Maximum 1 A

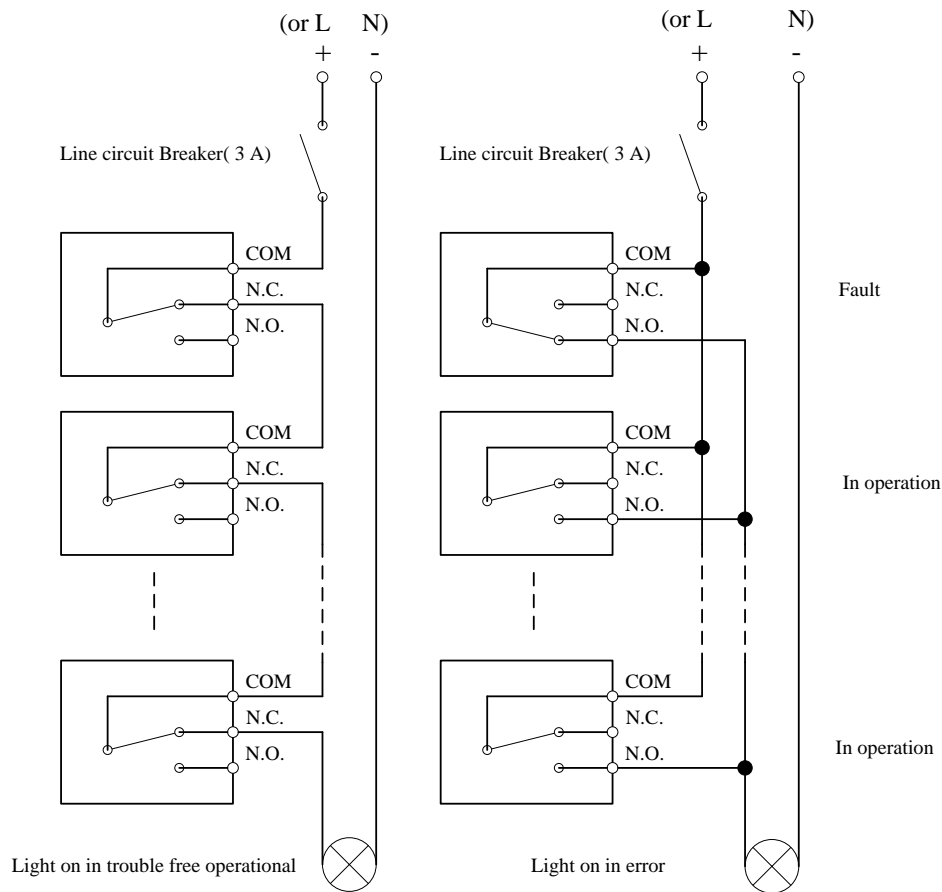
Different modes of dry contact output can be accessed by connecting different pins of the P205 connector, as shown in following table.

**Table 7.3 - Working Modes of Dry Contact**

Dry contact communication port	Status in fault condition	Status without fault condition
P205: N.O. — COM	Closed	Open
P205: N.C. — COM	Open	Closed

**Connection Plan:**

You can connect a LED or other loads to indicate the operational status of the inverter, as shown in the following figure:



**Figure 7.10 - Dry Contact Communication Schematic Diagram**

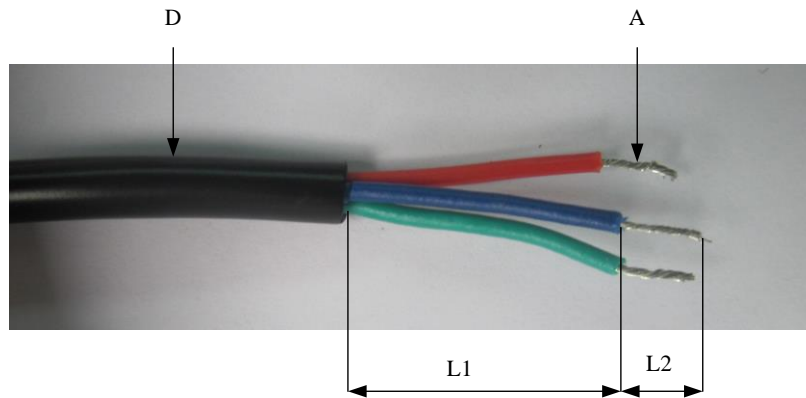
If you connect the contact port to the power distribution grid, you must install an individual miniature circuit-breaker between the dry contact and the power distribution grid.

**Dry Contact Communication Cable Connection:**

**Warning: If the unit is running, turn off both disconnects and wait 5 minutes before performing any work.**

- a.) Remove the plugs from holes for suitable cable conduits of 3/4 inch.
- b.) Put the dry contact communication cable through the cable conduit and inside the wiring box.
- c.) Use double-layer insulated cables. Strip the cables according to the following requirements.

Tool: Wire stripping pliers



**Figure 7.11 - Wire Stripping**

**Table 7.4 Cable Set-Up**

Position	Description	Value
	Cable type	Double-layer insulated cable
D	Outer diameter	4.5 mm~ 6 mm
A	Cross-section area of conductor	0.2 mm <sup>2</sup> ~ 0.75 mm <sup>2</sup>
L1	Length of stripped outer wire skin	Maximum 15mm
L2	Length of stripped inner wire skin	Maximum 7 mm

d.) Connect wires to the terminal.

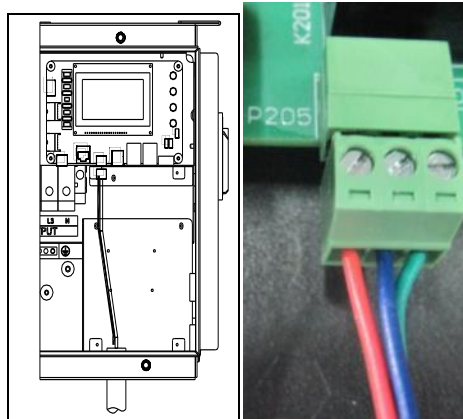
Tool: 2 or 2.5mm flat screwdriver



No.	Cable Color	Function
1	Red	N.O.
2	Blue	N.C.
3	Green	COM

**Figure 7-12 - Wire Connection**

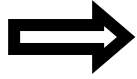
Plug the cable terminal into the P205 connector.



**Figure 7.13 - Dry Contact Communication Cable Connection**

## 8.0 Commissioning the Inverter PV System

Before commissioning, ensure that the inverter is mounted, all connections are made, and the inverter is ready to power up.



**NOTE:** Make sure all tools, parts, etc., are removed from the vicinity of the inverter before turning it on.



**WARNING:** Make a final check of all AC and DC wiring to the inverter and in the system before turning on.



**WARNING:** Connecting the inverter to the electric utility grid must only be completed after receiving prior approval from the utility company. Installation must be performed only by qualified personnel/licensed electrician(s).



**NOTE:** With the PV modules connected and inverter disconnect switches still off, perform a final check of the PV voltage and polarity once more using a digital volt meter and probing the positive (+) and negative (-) PV connections.

### 8.1 Turning On the Inverter

1. Turn on the dedicated three-phase circuit breaker or disconnect switch at the building service.
2. Turn on AC disconnect.
3. Turn on DC disconnect.

### 8.2 Operation

The inverter will connect to the electric grid when the DC voltage first exceeds 330VDC (strike voltage) and 300W of power is available. The inverter will shut down when the DC voltage falls below 300VDC.

### 8.3 Turning Off the Inverter

1. Choose “4 settings” from the **Main Menu**, and press **ENT**.
2. Choose “1 ON/OFF”. Move the cursor to “OFF” and press **ENT**.
3. The inverter will slowly ramp down the current and shutdown.
4. Turn off the DC disconnect followed by the AC disconnect.

## 9.0 LCD and LED Indicators

The inverter operates automatically without the need for user interaction. The LCD and LED indicators on the front of the inverter provide valuable operating information.

### 9.1 LCD

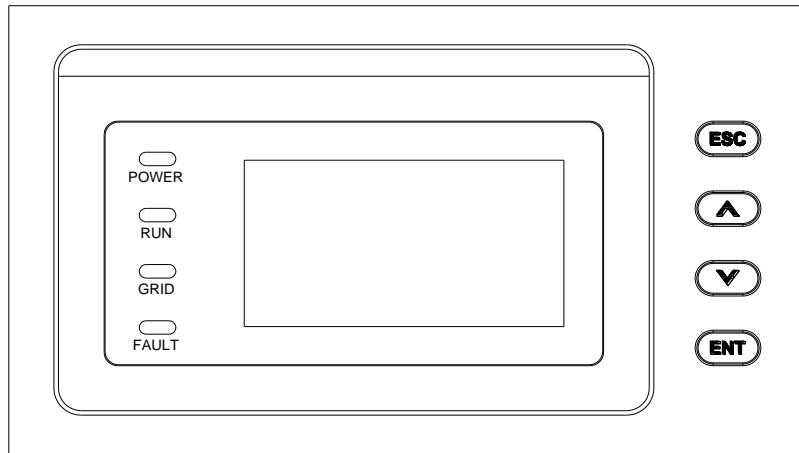


Figure 9.1 – LCD

The four touch keys below are available to help the customer scroll through the information.





Key	Description	Function
	Escape key	Back/End/Mute
	Enter key	Confirm entering the menu/Confirm set point
	Up	Page-up in selection menu/+1 setting increment
	Down	Page-down in selection menu/-1 setting decrement

Table 9.1 – Key Descriptions

The LEDs on the left indicate the operational status of the inverter.

LED Light	Status	Indication	Troubleshooting
<b>Power</b>	Light on	DC voltage available at the inverter	No need, Standard Operation
	Light off	Low DC or possible power supply problem	1. Check DC input polarity is correct. 2. Verify DC voltage above 180VDC. 3. Verify DC disconnect switch is on.
<b>RUN</b>	Light on	Inverter is producing power	No need, Standard Operation
	Flash	Derating (light on 0.5s, light off 1.5s)	Verify Inverters ambient temperature isn't above 45°C. <b>NOTE:</b> If the input power is above the rated output power the inverter will derate.
	Light off	Inverter is not producing power	1. Verify that there is no Snow on the array. 2. Check if Error light is on or flashing; if so skip to Section 10.
<b>GRID</b>	Light on	AC voltage is available at the inverter	No need, Standard Operation
	Flash	AC voltage out of setting range (light on 0.5s, light off 1.5s)	Check AC voltage and verify it is within range IEEE 1547 specified range.
	Light off	No AC voltage at the inverter	Verify that AC is available at the inverter.
<b>FAULT</b>	Light on	Indicates a possible fault	Note the LCD message and refer to the Fault part of Section 10.
	Slow flash	Indicates an Alarm (light on 0.5s, light off 2s)	Note the LCD message and refer to the Alarm part of Section 10.
	Fast flash	Indicates protective action being triggered (light on 0.5s, light off 0.5s)	Note the LCD message and refer to the Protection part of Section 10.
	Light off	No fault	No need, Standard Operation

**Table 9.2 – LED Indicators Meaning**

## 9.2 Screen Descriptions




### 9.2.1 Main Screen (Default)

Press **ESC** to move from the **Main (Default)** screen into the **Start Menu**.

### 9.2.2 Start Menu

1. Operation Info
2. Alarm
3. History
4. Settings
5. Power Dispatch

### 9.2.3 Operation Info Menu




The **Info Menu** displays the data stored in the inverter memory. Use the   buttons to scroll **UP** and **DOWN** through the list. Pressing  will take the screen back to the **Start Menu**.

<div style="border: 1px solid black; padding: 5px; width: fit-content;">1 OP.Info</div> <div style="margin-left: 20px;">→</div>	EDay 23.5kWh PDayPk 19kW DayT 12.1 h	<i>AC Energy (EDay) Energy (kWh)</i>	<i>Cumulative AC</i>	
	Uab 400.2V Ubc 400.9V Uca 399.7V Freq 60.0Hz	<i>AC Power Output (PDayPk) (kW)</i>	<i>AC Power Output</i>	<i>Hours</i>
	Ia 13.9A Ib 14.1A Ic 13.1A	<i>Run Time (DayT)</i>	<i>AC1 Voltage (Uab)</i>	<i>AC Voltage (V)</i>
	Tmod 78.2C Tamb 50 C	<i>AC2 Voltage (Ubc)</i>	<i>AC Voltage (V)</i>	<i>AC Voltage (V)</i>
	Upv 1 360.0V Ipv1 14.7A Upv 2 360.4V Ipv2 14.3A	<i>AC3 Voltage (Uca)</i>	<i>AC Voltage (V)</i>	<i>AC Frequency (Hz)</i>
	Sac 17KVA Pac 16.7kW	<i>AC Freq.</i>	<i>AC Current (Ia)</i>	<i>AC Current (A)</i>
		<i>AC2 Current (Ib)</i>	<i>AC Current (A)</i>	<i>AC Current (A)</i>
		<i>AC3 Current (Ic)</i>	<i>Heatsink Temperature</i>	<i>°C</i>
		<i>Heatsink Temperature</i>	<i>Ambient Temperature</i>	<i>°C</i>
		<i>Ambient Temperature</i>	<i>DC Voltage (Upv1)</i>	<i>DC Voltage (V)</i>
	<i>DC Voltage (Upv1)</i>	<i>DC Current (Ipv1)</i>	<i>DC Current (A)</i>	
	<i>DC Current (Ipv1)</i>	<i>DC Voltage (Upv2)</i>	<i>DC Voltage (V)</i>	
	<i>DC Voltage (Upv2)</i>	<i>DC Current (Ipv2)</i>	<i>DC Current (A)</i>	
	<i>DC Current (Ipv2)</i>	Sac	<i>Apparent Power (kVA)</i>	
	Sac	Pac	<i>Real Power (kW)</i>	

**Table 9.3 – Operation Information Submenu**



### 9.2.4 Alarm Menu

The **Alarm Menu** displays inverter alarms and faults, some of which may be modified with the keypad. Use the  and  buttons to scroll up and down through the list. Pressing  will take the screen back to the **Start Menu**. Any fault message will be indicated in the **Alarm Menu**.

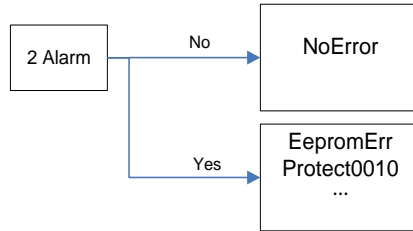





Figure 9.2 – Present Fault Information

### 9.2.5 History Menu

The **History Menu** displays inverter data history, some of which may be modified with the keypad. Use the  and  buttons to scroll **UP** and **DOWN** through the list. Pressing  will take the screen back to the **Start Menu**.

The following information can be found in the menu:

1. Up to 100 entries of the most recent fault messages recorded and retrieved.
2. The last 21 days of operation history data is available.
3. Product software/hardware and serial number information.
4. Cumulative generated power information.

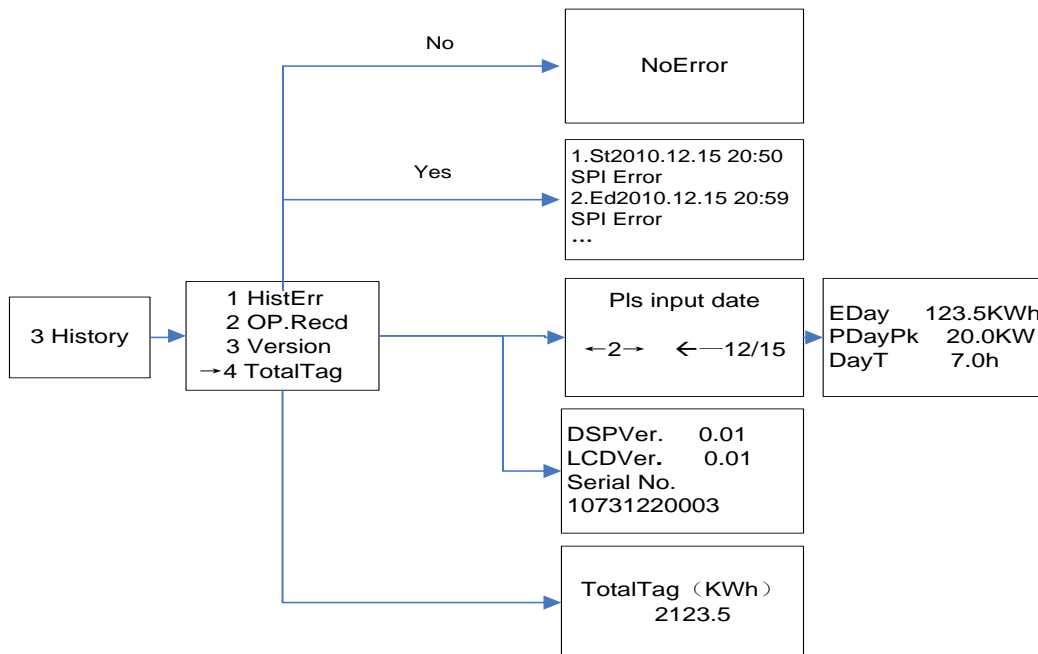
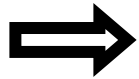


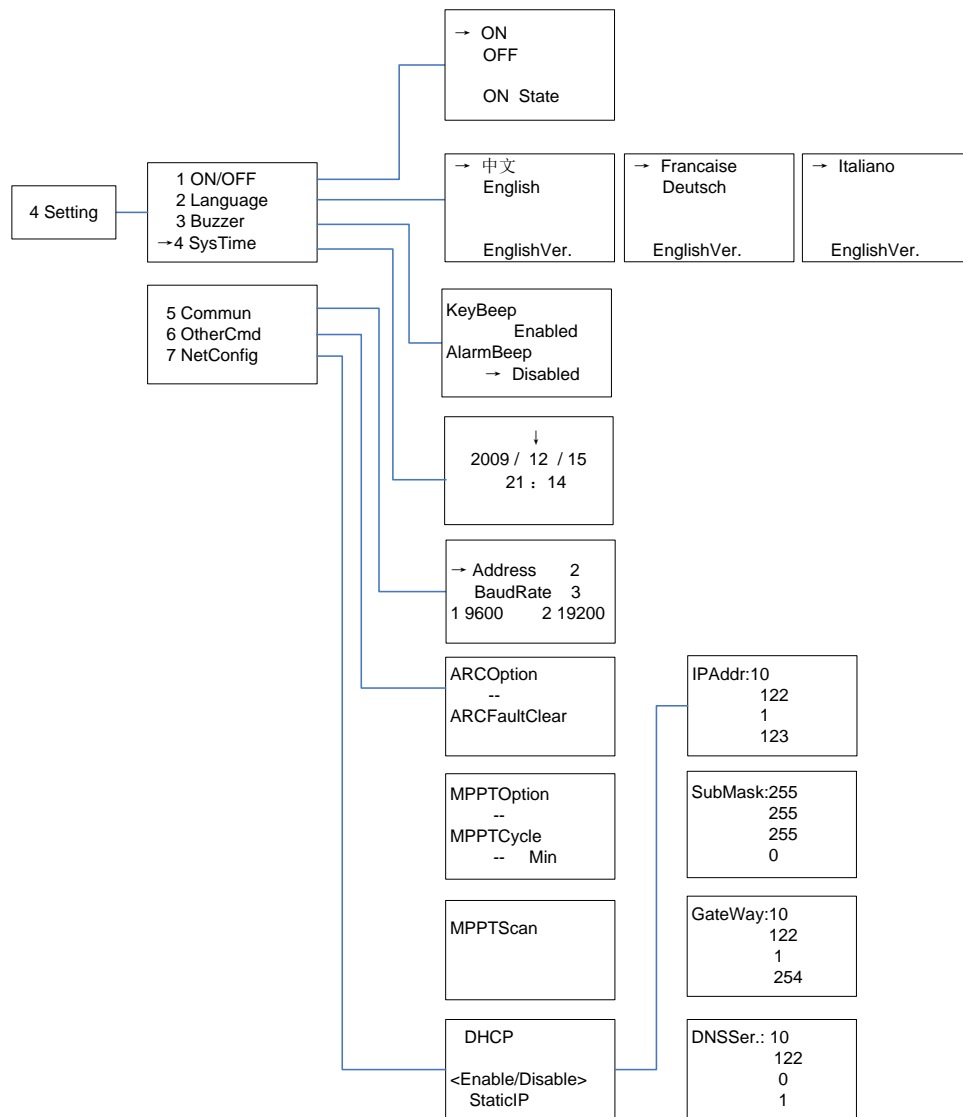
Figure 9.3 – History Menu and Submenu

### 9.2.6 Settings Menu

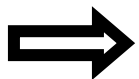
The inverter parameters can be adjusted by using commands in the **Settings Menu** as shown in Figure 9.7 below. Options such as Power ON/OFF, Language, Sounds, Date, Communications, and MPPT can simply be changed/set from the **Settings Menu**.



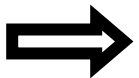
**NOTE:** When prompted for a password, enter the following: **UP, DOWN, UP, DOWN**, then **ENT**.



**Figure 9.4 – System Setup Menu and Submenu**



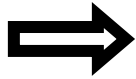
**NOTE:** The inverter and SolrenView (see Section 7.7) must have the same **Baud Rate (9600)** and **Address (Inverter ID)** for proper communication.



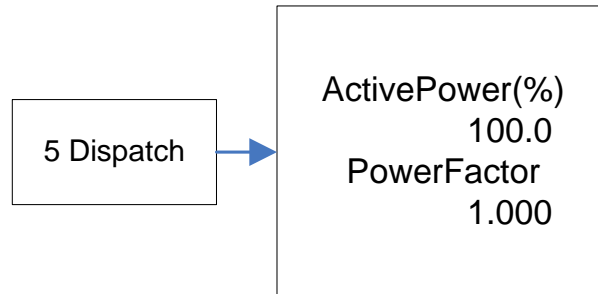
**NOTE:** When connecting multiple inverter (up to 16) to a single data logger each inverter requires a unique **Address (Inverter ID)**.

### 9.2.7 Power Dispatch

“ActivePower” and “PowerFactor” parameters can be set up through the LCD as well as remotely.



**NOTE:** These parameters are only adjustable with permission from the local utility.



**Figure 9.5 – Active Power and Power Factor Settings**



**NOTE:** When prompted for a password, enter the following: **UP, DOWN, UP, DOWN**, then **ENT**.



**NOTE:** It is often common at sites with High AC voltage above 1.05p.u that the Utility would like to modify the power factor to reduce the voltage at the point of common coupling. This can be done by setting the inverter to absorb vars. For the PVI 23-28TL this can be achieved by setting the inverter to a negative value. For example, one would set the power factor to -0.95 which will help reduce the AC voltage at site by allowing the inverter to absorb vars.

If you are interested in enabling these features or in further understanding their capabilities, please contact us at [support@solectria.com](mailto:support@solectria.com) for more details.

## 10.0 Troubleshooting and Inverter Messages

Although the inverter is designed for many years of power production, there may be instances where error messages are displayed on the LCD. This table can be used to help identify the error and resolve it.

Type	Name	Definition	Possible Causes	Recommended Solutions
Alarm	1. TempSensorErr	Abnormal temperature reading	1. Internal temperature sensor is making poor contact.	1. Verify temperature reading off of the display. 2. Switch off the inverter's internal disconnects. 3. Switch the Inverter back on. 4. If error does not clear, contact Solectria Customer Service.
			2. Temperature sensor is damaged.	
Alarm	2. SPICommErr	Inverter's internal communication failure	1. Poor connection of the inverter's internal communication connector.	1. Observe for 5min and see whether the alarm is cleared automatically. 2. Switch off the inverter's internal disconnects. 3. Switch the Inverter back on. 4. If error does not clear, contact Solectria Customer Service.
Alarm	3. IntFanErr	Inverter's internal fan (can't be seen externally) is not operating properly	1. Fan service life has expired.	1. Observe for 5min and see whether the alarm is cleared automatically. 2. Switch off the inverter's internal disconnects. 3. Switch the Inverter back on. 4. If error does not clear, contact Solectria Customer Service.
			2. Fan connector is making a poor connection.	
Alarm	4. ExtFanErr	One of the three external fans is not operating properly	1. Fan is blocked.	1. Observe for 5min and see whether the alarm is cleared automatically. 2. Switch off the inverter's internal disconnects. 3. Check the fan blades for debris.

			2. Fan service life has ended.	4. Switch the Inverter back on. 5. If error does not clear, contact Solectria Customer Service.
			3. Fan socket connecter is making a poor connection.	
Alarm	5. EepromErr	Incorrect memory reading	1. A problem with the inverter's internal memory.	1. Observe for 5min and see whether the alarm is cleared automatically. 2. If error does not clear, contact Solectria Customer Service.
Protection	1. Arc Board Error	Internal Arc board self-check error	1. Possible communication error between Arc board and Inverter. 2. Abnormal reading within the Arc board.	1. Observe for 5min and see whether the alarm is cleared automatically. 2. If error does not clear, contact Solectria Customer Service.
Protection	2. OverTemp	Ambient temperature or temperature inside inverter is too high	1. Ambient temperature outside the inverter is too high. 2. Fan is blocked. 3. Poor cooling due to improper installation.	1. Confirm that external ambient temperature is within the specified range of operating temperature. 2. Verify air inlet and outlet are not blocked. 3. Verify fan is not blocked. 4. Verify proper spacing was followed during installation. 5. Observe for 30min and see whether the alarm is cleared automatically. 6. If error does not clear, contact Solectria Customer Service.
Protection	3. GridV.OutLim	Grid voltage exceeds the specified range	1. Grid voltage is abnormal. 2. No AC voltage at the inverter. 3. Improper AC wiring (see Section 6.1). 4. Loose AC connections.	1. Observe for 10min and see whether the alarm is cleared automatically. 2. Verify Grid Voltage is within range. 3. Verify proper AC wiring. 4. If error does not clear, contact Solectria Customer Service.

Protection	4. GridF.OutLim	Grid voltage frequency is abnormal	1. Grid frequency is out of range.	1. Observe for 10min and see whether the alarm is cleared automatically. 2. Verify grid frequency is within range. 3. Verify proper AC wiring. 4. If error does not clear, Contact Solectria Customer Service.
			2. Loose AC connections.	
Protection	5- PV1 (2) VoltOver	DC input voltage exceeds the specified value	1. DC over-voltage.	1. Observe for 30min and see whether the alarm is cleared automatically. 2. Verify DC open circuit input voltage is within specified range. 3. Switch off the inverter's internal disconnects. Switch the Inverter back on. 4. If error does not clear, contact Solectria Customer Service.
Protection	6. PV1 (2) Reverse	DC inputs connected with incorrect polarities	1. PV positive pole and negative pole are connected in reverse.	1. Verify DC voltage polarity is correct on all inputs. 2. If error does not clear, contact Solectria Customer Service.
Protection	7. GFCI.Err	DC leakage current is above recommended value	1. Excessive parasitic capacitance on PV module due to insulation failure.	1. Observe for 10min and see whether the alarm is cleared automatically. 2. Contact System installer to check installation for possible Ground Fault. 3. If error does not clear, contact Solectria Customer Service.
			2. Abnormal grounding conditions.	
Protection	8. IsolationErr	DC insulation impedance to ground	1. Insulation to ground is below recommended value.	Contact System installer to check installation for possible Ground Fault.

Protection	9. IntProtect 0010-0260	Internal problem within the inverter	1. One of the inverter’s internal protection features was triggered causing the inverter to shut down.	1. Observe for 10min and see whether the alarm is cleared automatically. 2. If error does not clear, contact Solectria Customer Service.
Protection	10. Arc Protect	Inverter shuts down due to a possible Arc fault concern	1. An internal Arc fault occurred on the DC side.	1. Have qualified Electrical Personnel inspect wiring section of Inverter. 2. If no issues are found, contact Solectria Customer Service.
			2. Fault with the Arc board.	
Fault	1. IntFault0010- 150	Internal non- critical fault within the inverter	1. A fault occurred internally within the inverter.	1. The inverter will restart once the fault is cleared. 2. If error does not clear, contact Solectria Customer Service.

**Table 10.1 – Troubleshooting**

## 11.0 Product Maintenance

Regular maintenance helps extend product lifetime and performance.

### 11.1 Check the Electrical Connection

Check all the cable connections once every 6 months, by performing the following steps:

1. Turn off inverter DC disconnect.
2. Turn off inverter AC disconnect.
3. Lock out all DC and AC sources to the inverter.
4. Verify absence of DC and AC voltages at the wiring box.
5. Check for loose or untightened cables; follow torque and safety instructions in the manual.
6. Check for cable damage, especially whether the cable surface is scratched or smooth. Repair or replace the cables if necessary.

### 11.2 Clean the Air Vent Filter

On average, it is recommended to check the air vent of the fans once every 6 months. Do so by performing the following steps:

1. Turn off inverter DC disconnect.
2. Turn off inverter AC disconnect.
3. Lock out all DC and AC sources to the inverter.
4. Verify absence of DC and AC voltages at the wiring box.
5. Use Philips Screw driver to remove Vent covers.
6. Clean vents using dry cloth.
7. Return Screws (torque = 10in-lbs).

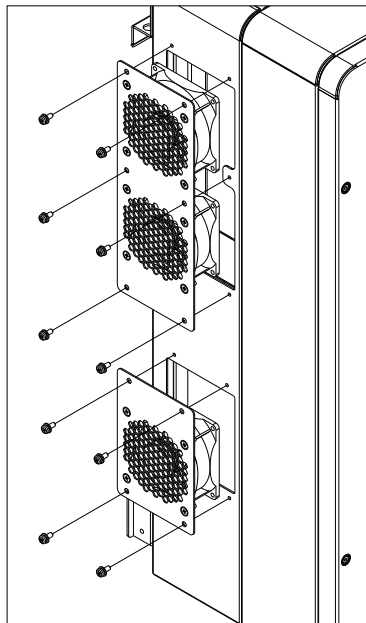


Figure 11.1 – Fan Vent Locations



## 12.0 Product Warranty and RMA Policy

The current warranty and RMA statement for the product is available online at <http://www.solectria.com/support/documentation/warranty-information/grid-tied-inverter-warranty-letter/>. If you do not have access to the internet or to request a copy to be mailed to you, please contact our Technical Service department 978-683-9700 x 2.

## 13.0 Technical Data

### 13.1 Output AC Specifications

The inverters are designed to feed power into a standard 60Hz, three-phase AC utility service provided within a facility with a rating of not less than the rating of the inverter(s) connected to it.

The inverter is designed to work with the range of AC voltages for a three-phase service defined by IEEE 1547-2003 and ANSI C84.1.

	PVI 23TL	PVI 28TL	Unit
Nominal Output Voltage	480	480	VAC
Operating AC Voltage Range	88 – 110%		VAC
Operating Frequency	60		Hz
Output Frequency Range	59.3-60.5 (adjustable 55-65)		
Power Factor	Unity, > 0.99 (adjustable ±0.8)		
Total Harmonic Distortion (THD) @ Rated Load	< 3%		
Continuous Output Power	23	28	kW
Max Output Current	27.7*	33.7*	Amps
Grid Connection Type	3ø+/N/GND		
One Cycle Short Circuit Current (L-N/GND)/Duration	52.9Amps RMS/20ms		
One Cycle Short Circuit Current (L1/L2/L3)/Duration	69.6Amps RMS/20ms		

\* Change is effective after S/N 12241447010 and 12231447001. For any prior S/N refer to Rev.D of this manual available thru Solectria Customer Service.

**Table 13.1 – AC Output Specifications**

	PVI 23TL	PVI 28TL
Peak Efficiency	98.6%	98.5%
CEC Weighted Efficiency	98.0%	98.0%
Tare Loss	1W	1W

**Table 13.2 – Efficiency of Inverters**

### 13.2 Input DC (PV) Specifications

	PVI23TL	PVI 28TL	Units
Absolute Maximum Input Voltage	1000		VDC
Maximum PV Power	15.5 per MPPT (31)	19 per MPPT (38)	kW
Operating Input Voltage	300-900		VDC
Strike (Startup Voltage/Power)	330VDC/300W		
MPPT Input Voltage Range	480-800	500-800	VDC
MPPT Trackers	2 with 4-Fused Inputs per Zone		
Maximum Operating Input Current	25 per MPPT (50)	29 per MPPT (58)	Amps
Maximum Short Circuit Current	41 per MPPT (82)	48 per MPPT (96)	Amps

**Table 13.3 – DC Input Specifications**

### 13.3 Other Specifications

Integrated String Combiner Option	8 String Inputs , 12-15 A (4 per MPPT)
Operational Ambient Temperature	-13° to 140°F (-25° to 60°C) Derating occurs above 45°C
Storage Temperature	-22° to 158°F (-30° to 70°C)
dBA (Decibel) Rating	< 55dBA @ 3m
Operating Altitude	13123ft/400m (derating from 6562ft/2000m)
Inverter Enclosure	Type 4
Safety Listings & Certifications	UL 1741/IEEE 1547, IEEE 1547.1, UL 1699B CSA C22.2#107.1, FCC part 15 B
Certification Agency	CSA
Weight	122lbs (55kg)
BTU Rating	1911BTU/Hr

**Table 13.4 – Other Specifications**

### 13.4 Temperature Derating Curve

Figure 13.1 shows the standard power derating curve for a PVI 23-28TL inverter. The inverter operates at full power up to 45°C and derates linearly until 60°C where it shuts down to protect itself.

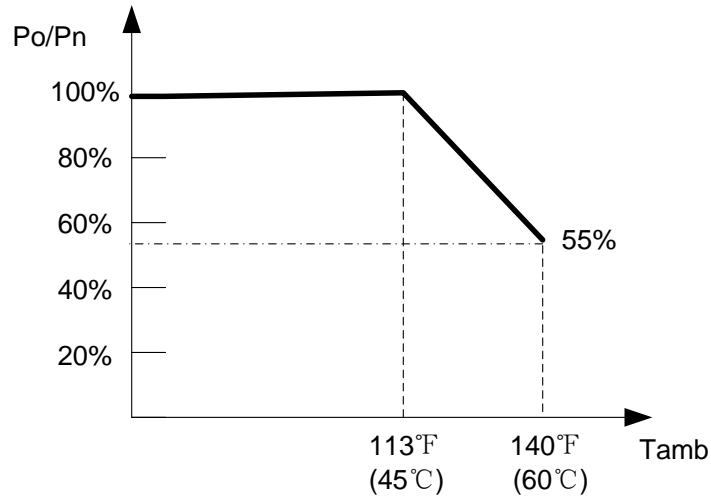


Figure 13.1 – Temperature Derating Curve

### 13.5 Power Derating Curve Out of MPPT Zone

Figure 13.2 below shows the standard derating curve outside of the MPPT zone. Inverters derate linearly outside their rated MPPT range.

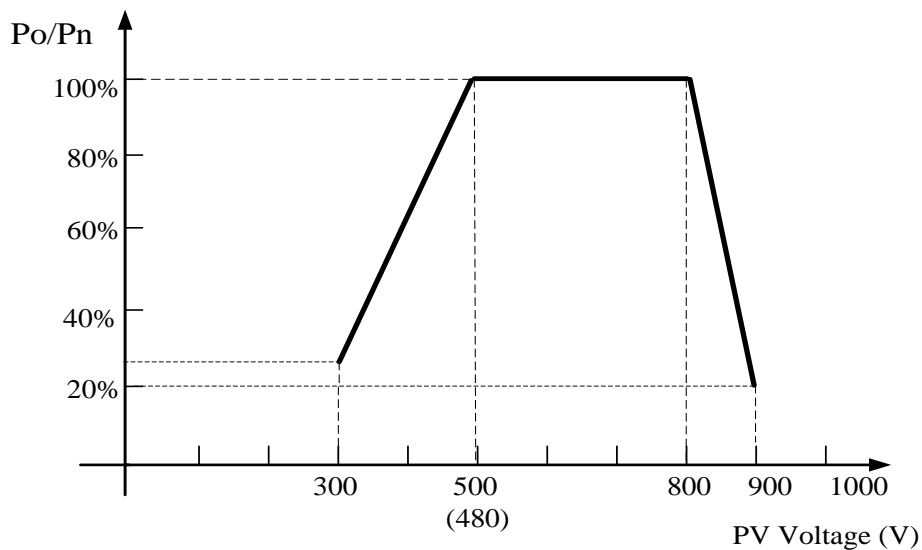


Figure 13.2 – Power Derating Outside of MPPT Range

### 13.6 Altitude Derating Curve

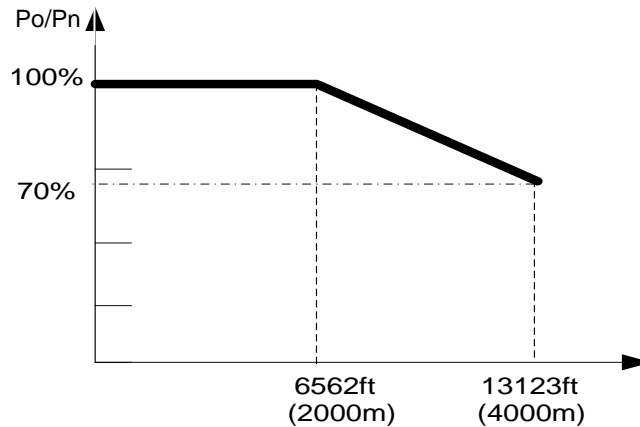


Figure 13.3 – Derating at High Altitudes

### 13.7 Internal Circuit Diagram

The basic power flow within the PVI 23-28TL series of inverters is below. Note that the GFDI circuit is not depicted.

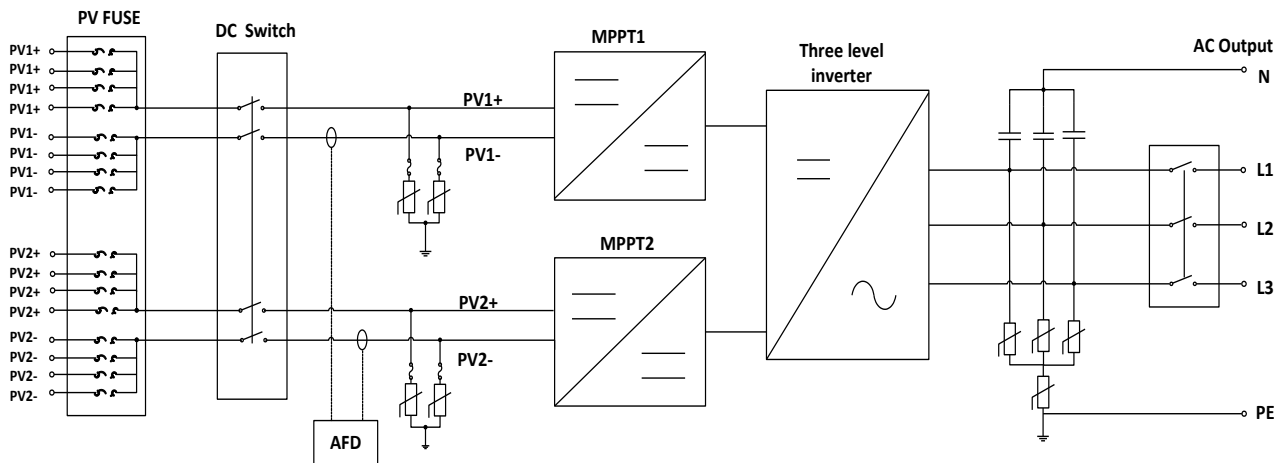


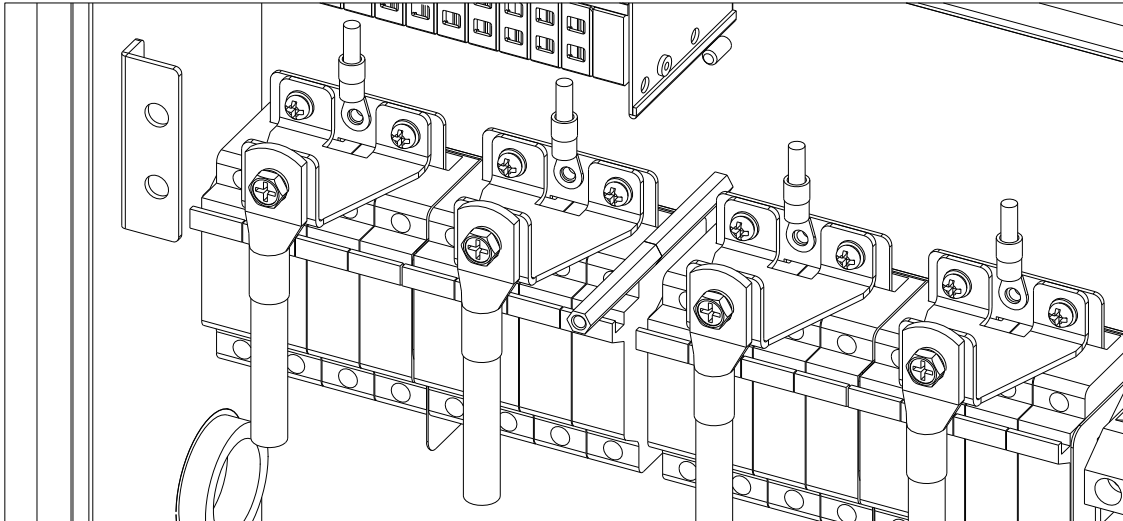
Figure 13.4 – Simplified Internal Circuit Diagram for PVI 23-28TL Series Inverters

## 14.0 Accessory Options

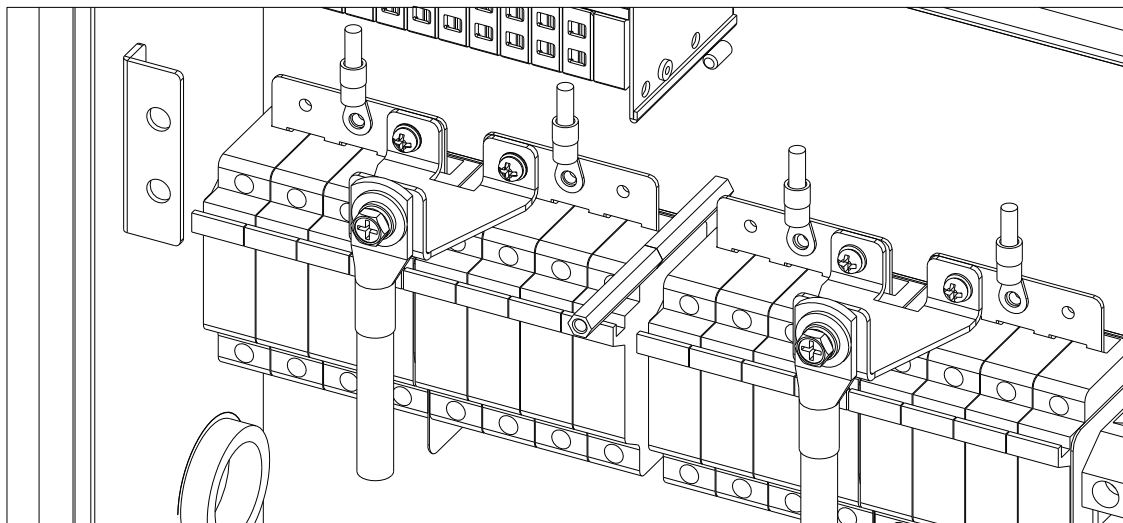
The PVI 23-28TL comes with several options that allow the inverter to support a wide range of real life applications.

### 14.1 Fuse Bypass

OPT-FUSEBYPASS-PVI-23-28, as discussed in Section 5.3, allows customers to combine the DC inputs outside the inverter and enter with only one or two combined inputs.



**Figure 14.1 – Fuse Bypass Two Inputs (Two Independent MPPTs)**



**Figure 14.2 – Fuse Bypass Single Input (Combined MPPT)**

### 14.2 SolrenView Monitoring

SRV-LCD-3PTL-OUTDOOR, as discussed in Section 7.2, allows customers to purchase the only monitoring system that is designed to support PVI 23-28TL to the fullest. SolrenView can be placed next to the inverter. RS-485 and DC wires can be fed into SolrenView directly off of the inverter.

### 14.3 Shade Cover

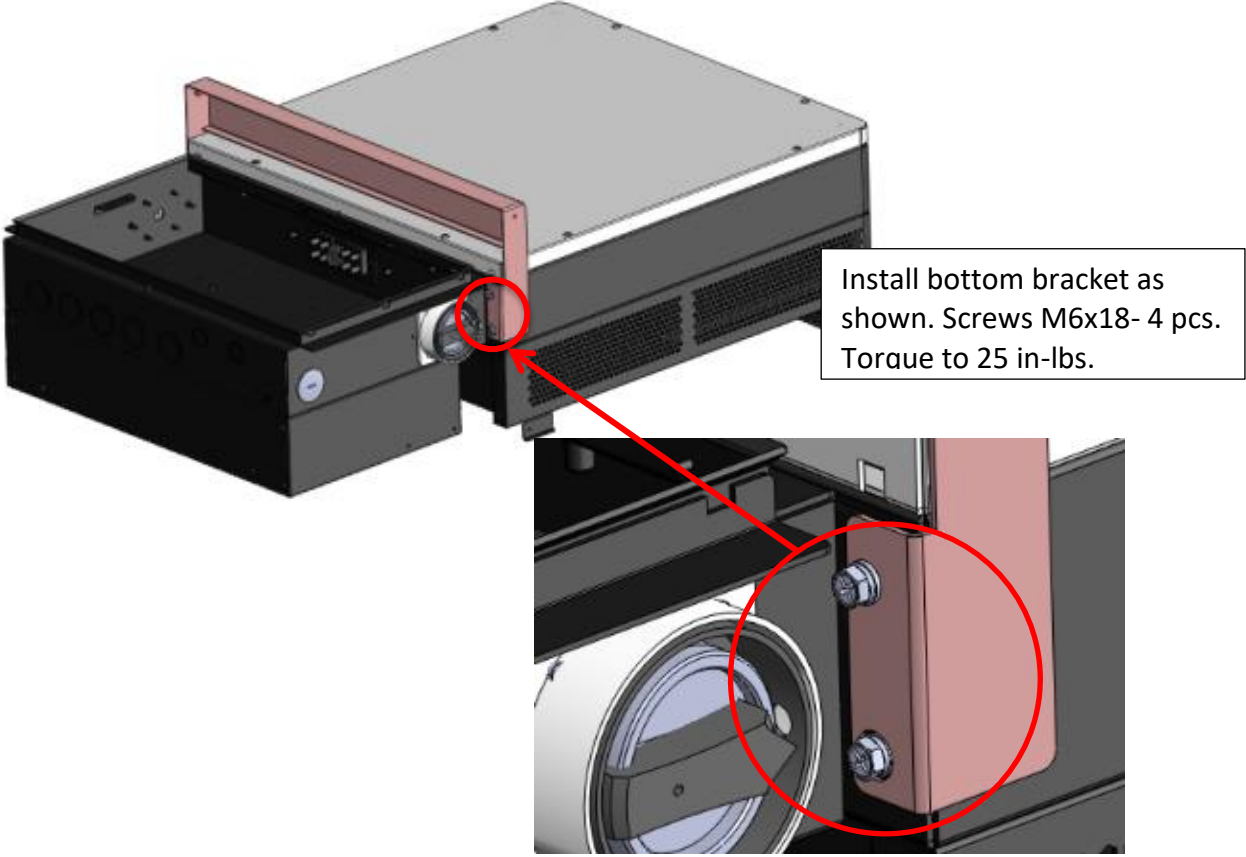
OPT-SHADECOVER-PVI-23-36 is specifically designed for inverters mounted at a 15-degree tilt angle. It protects the inverter from harsh weather and direct sunlight/extremely hot temperatures while reducing thermal gain on the inverter and increasing energy production.

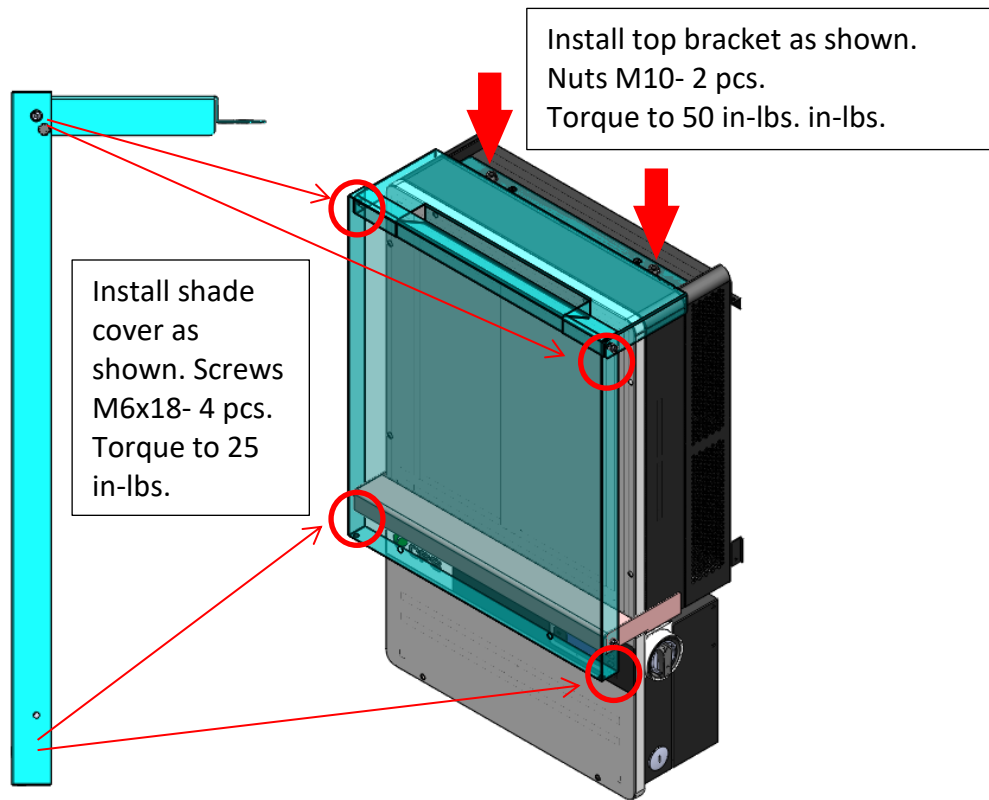
PVEL, now part of BEW/DNV Kema, performed field testing of the shade cover temperature effects of the inverter case temperatures. The normalized data analysis showed 2-15% less temperature rise on the inverter case temperatures. Front, Back and Top temp rise was 6%, 4%, 15% lower with the Shade cover (as shown in table below).

Measurement Location	Inverter1					
	Top	East	West	Front	Back	Bottom
Without Shade Plate [ $T_{Case}/T_{Ambient}$ ]	1.98	1.53	1.71	1.54	1.47	1.26
Shade Plate on Inverter1 [ $T_{Case}/T_{Ambient}$ ]	1.67	1.47	1.66	1.45	1.41	1.23
Percent Difference [Shade Plate-Without Shade Plate](%)	-15.65	-3.36	-3.01	-6.26	-4.20	-2.34

**Table 5.1 – Normalized (to Measure Ambient Temperatures) Case Temperatures at Various Locations on the Inverter**

**14.3.1 Installation instructions for OPT-SHADECOVER-PVI-23-28TL**





**Figure 14.4 – Inverter With Shade Cover Installed**

#### **14.4 AC & DC Disconnect Covers**

OPT-DISCOCOVER-PVI-23-28TL is a tamper resistant cover for the AC and DC disconnects. It is recommended for customers that have inverters in public places so the disconnects cannot be turned while the inverter is running.



**Figure 14.5 – Tamper Proof Cover**



## 15.0 Appendices

### Appendix A – PVI 23-28TL Datasheet

<https://solectria.com/support/documentation/inverter-datasheets/pvi-23tl-pvi-28tl-pvi-36tl-transformerless-3-ph-string-inverters-datasheet/>

### Appendix B – String Sizing Tool

<http://solectria.com/support/string-sizing-tool/>

### Appendix C – Contact Information

Yaskawa – Solectria Solar  
360 Merrimack Street  
Building 9, Floor 2  
Lawrence, Massachusetts 01843  
USA

Tel:	978.683.9700
Fax:	978.683.9702
Sales/ general info:	<a href="mailto:inverters@solectria.com">inverters@solectria.com</a>
Technical Support & Service:	978-683-9700 x2
Website:	<a href="http://www.solectria.com">www.solectria.com</a>

### Appendix D – Authorized Distributors

<http://www.solectria.com/products/how-to-buy/>

## Appendix E – UL 1741 / UL 1699B/ IEEE 1547 / CSA 22.2#107.1 Authorization to Mark

	
<h1>Certificate of Compliance</h1>	
<b>Certificate:</b> 2665124	<b>Master Contract:</b> 259363
<b>Project:</b> 2716241	<b>Date Issued:</b> April 1, 2014
<b>Issued to:</b> Solectria Renewables,LLC. 360 Merrimack St.Bldg 9, Lawrence, MA,01843, USA <b>Attention:</b> Mr. James Worden	
<p><i>The products listed below are eligible to bear the CSA Mark shown with adjacent indicators 'C' and 'US' for Canada and US or with adjacent indicator 'US' for US only or without either indicator for Canada only</i></p>	
	
<b>Issued by:</b> Kyle Song Kyle Song	
<b><u>PRODUCTS</u></b>	
CLASS 5311 09 - POWER SUPPLIES - Distributed Generation Power Systems Equipment CLASS 5311 89 - POWER SUPPLIES - Distributed Generation Power Systems Equipment - Certified to U.S. Standards	
Utility Interactive Inverter, Model PVI 23TL-480 and PVI 28TL-480, permanently connected.	
For details related to rating, size, configuration, etc., reference should be made to the CSA Certification Record,Certificate of Compliance Annex A, or the Descriptive Report.	
<b><u>APPLICABLE REQUIREMENTS</u></b>	
CSA-C22.2 No. 107.1-01 - General Use Power Supplies	
*UL Std. No.1741-Second Edition - Inverters, Converters, Controllers and Interconnection System Equipment for Use With Distributed Energy Resources(January 28, 2010)	
UL 1699B - Outline of Investigation for Photovoltaic (PV) DC Arc-Fault Circuit Protection (Issue Number 2, January 14, 2013)	
DQD 507 Rev. 2012-05-22	Page 1