

Application Note

Interconnection Guidelines for Yaskawa Solectria Solar XGI 1500 & XGI 1000 Inverters

XGI 1000:

XGI 1000-50/60-UL, XGI 1000-60/60-UL,
XGI 1000-60/65-UL, XGI 1000-65/65-UL

XGI 1500:

XGI 1500-125/125-UL, XGI 1500-125/150-UL,
XGI 1500-150/166-UL, XGI 1500-166/166-UL,
XGI 1500-175-480, XGI 1500-200/200-480,
XGI-225-600, XGI 1500 250/250-600

October 26, 2022

1. Interconnection Service Requirements

Yaskawa Solectria Solar's XGI 1000 and XGI 1500 three-phase transformerless inverters require AC output connection to a wye configured service with a solidly grounded neutral. The XGI inverter leaves the factory with Neutral bonded to Equipment Ground; the Neutral is used by the XGI inverter for AC voltage sensing. Note that the XGI inverter comes with the necessary parts to isolate the Neutral terminal, when that is desired. It is not necessary to run a neutral conductor. However, if a neutral conductor is installed in the field between the service and the XGI inverter, it will not carry current. Therefore, if the installer chooses to run a neutral conductor between the transformer and the inverter, the size of the neutral conductor may be reduced to the same size as the EGC, but not smaller than the EGC. Acceptable service configurations are depicted in the table below.

Acceptable Service Configurations

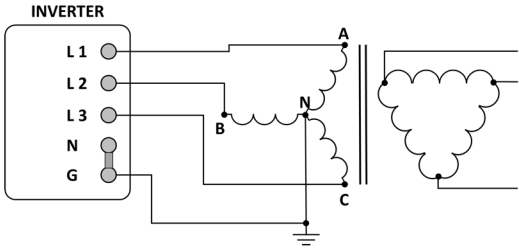
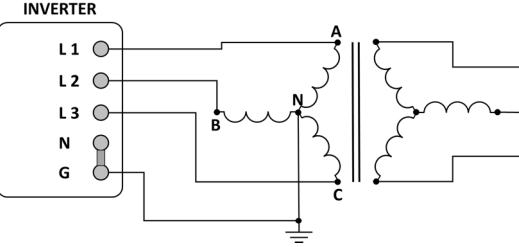
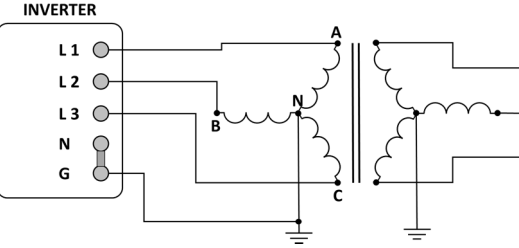
XGI 1500 Inverter-Facing Transformer Winding	System Configuration	XGI 1500 Utility-Facing Transformer Winding	XGI 1500 Inverter Compatibility
Grounded-WYE	Neutral Bonded to Ground 	Delta	Compatible
Grounded-WYE	Neutral Bonded to Ground 	WYE	Compatible
Grounded-WYE	Neutral Bonded to Ground 	Grounded-WYE	Compatible

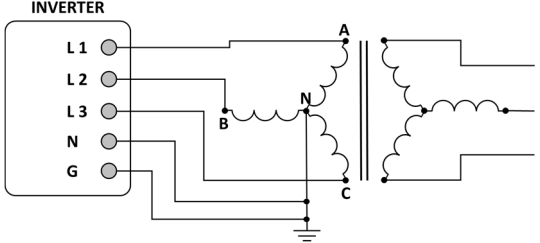
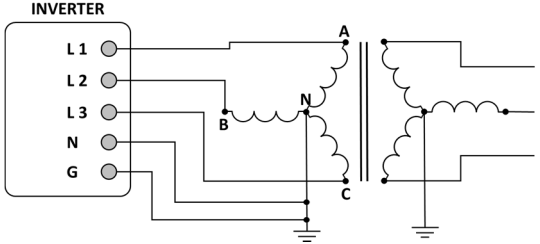
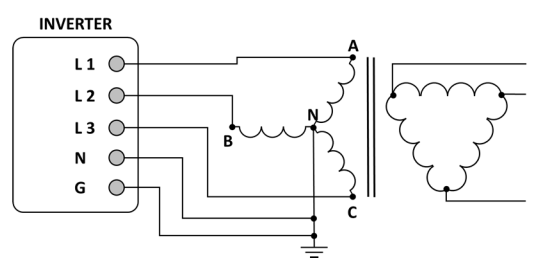
XGI 1000 Inverter-Facing Transformer Winding	System Configuration	XGI 1000 Utility-Facing Transformer Winding	XGI 1000 Inverter Compatibility
Grounded-WYE	<p style="text-align: center;">Isolated Neutral</p> 	WYE	Compatible
Grounded-WYE	<p style="text-align: center;">Isolated Neutral</p> 	Grounded-WYE	Compatible
Grounded-WYE	<p style="text-align: center;">Isolated Neutral</p> 	Delta	Compatible

Note: Any system configurations not shown in the tables above are NOT compatible with the XGI 1000 or XGI 1500 inverters, and an intermediary transformer must be used.

2. Paralleling Multiple Inverters

2.1 Maximum Numbers of Inverters in Parallel

The maximum number of Yaskawa Solectria Solar's XGI 1000 and XGI 1500 three-phase, transformerless inverters that may be connected in parallel to one common point of connection, in a single building block, is shown in the table below:

Inverter Model	Maximum Number of XGI Inverters Allowed in Parallel
XGI 1000-50/60-UL, XGI 1000-60/60-UL, XGI 1000-60/65-UL, XGI 1000-65/65-UL	60 inverters per transformer
XGI 1500-125/125-UL, XGI 1500-125/150-UL XGI 1500-150/166-UL, XGI 1500-166/166-UL	30 inverters per transformer
XGI 1500-175-480, XGI 1500-200/200-480, XGI-225-600, XGI 1500 250/250-600	30 inverters per transformer

2.2 Direct Connection to Grid Service

The Yaskawa Solectria Solar XGI 1000 and XGI 1500 three phase transformerless inverters may be installed in parallel with AC output at a single point of connection creating a low-voltage building block. The low voltage blocks may then be connected directly to grid service without a step-up transformer if the inverter AC voltage matches the supply voltage. The requirements for direct connection to grid service are:

1. The grid’s nominal voltage/frequency and variation range must follow U.S. grid standard/code.
2. The inverter AC voltage must match the supply voltage.
3. System voltage drop between the inverter’s AC output and the grid connection point should not significantly affect the grid voltage at the inverter. If the system AC voltage drop is too high, the inverter will disconnect from the grid due to AC over-voltage. The AC-side wiring voltage drop should be limited to minimize power loss in the wires. **Yaskawa Solectria Solar recommends that the AC voltage drop be < 2% of Vnom (nominal AC voltage) at maximum power production.** The temperature rise in cables and the ambient temperature should be considered in the voltage drop calculation.

Inverter Model	Nominal Voltage
XGI 1000-50/60-UL, XGI 1000-60/60-UL, XGI 1000-60/65-UL, XGI 1000-65/65-UL, XGI 1500-175-480, XGI 1500-200/200-480	480/277 VAC
XGI 1500-125/125-UL, XGI 1500-125/150-UL, XGI 1500-150/166-UL, XGI 1500-166/166-UL, XGI-225-600, XGI 1500 250/250-600	600/347 VAC

2.3 Connection via Transformer

The use of a transformer is acceptable if it is required to step-up/down nominal voltage and/or to comply with the above acceptable service configurations for Yaskawa Solectria Solar’s XGI 1000 and XGI 1500 three-phase transformerless inverters.

If the connection to the grid is through a transformer, then the following additional requirements apply:

1. The transformer impedance must be no greater than 6%.
2. No oversizing of the transformer is required by Yaskawa Solectria Solar. However, the transformer kVA rating must be at least the sum of the kVA ratings of all the XGI inverters connected to it.
3. Additionally, it is suggested that the transformer be selected based on IEEE C57.159-2016 *Guide on Transformers for Application in Distributed Photovoltaic (DPV) Power Generation Systems* and IEEE C57.91-2011 *Guide for Loading Mineral Oil Immersed Transformers*. It is the responsibility of the system designer to determine the reliability of the transformer and all other system parameters.

Example 1: 4.5 MWac building block with XGI 1500-225 inverters set to default kVA of 225kVA

The XGI 1500-225 inverters have a standard, continuous, apparent output power rating of 225 kVA. If twenty (20) of these inverters are paralleled onto one winding of a transformer, the minimum rating of the transformer should be calculated as follows:

Tr (minimum apparent power rating of transformer) = (# inverters) x (inverter apparent power rating)

$$Tr = 20 \times 225 \text{ kVA} = 4,500 \text{ kVA or } 4.5 \text{ MVA}$$

A transformer with a **minimum** rating of 4.5 MVA may be used with (20) XGI 1500-225 inverters in the default standard mode and connected in parallel to a secondary winding or to the low voltage side of the transformer.

Example 2: 4.5 MW building block with XGI 1500-225 inverters, apparent power overhead mode (via password protected selection)

XGI 1500-225 inverters in apparent power overhead mode have a continuous apparent output power rating of 250 kVA. If twenty (20) of these inverters are paralleled onto one winding of a transformer, the minimum rating of the transformer should be calculated by the following:

Tr (minimum apparent power rating of transformer) = (# inverters) x (inverter apparent power rating)

$$Tr = 20 \times 250 \text{ kVA} = 5,000 \text{ kVA or } 5 \text{ MVA}$$

A transformer with a **minimum** rating of 5 MVA may be used with (20) XGI 1500-225 inverters in apparent power overhead mode connected in parallel to a secondary winding or to the low-voltage side of this transformer.

Conclusion

System designs utilizing multiple inverters in parallel must follow the recommendations in this document. Additional requirements for installation of these inverters can be found in their respective Installation and Operation Manuals (<https://www.solectria.com/support/documentation/>). It is recommended that customers contact a Yaskawa Solectria Solar Application Engineer to review projects with complex AC system designs.

Yaskawa Solectria Solar is not liable or responsible for any damages, including indirect, special, incidental or consequential damage caused by reliance on the content presented, including, but not limited to any omissions, typographical errors, arithmetic errors or listing errors.

The technical information and cross references in this document are subject to further development, and Yaskawa Solectria Solar reserves the right to make changes at any time without notification.

For further information, please contact:

Yaskawa Solectria Solar
360 Merrimack Street
Lawrence, MA 01843
(978) 683-9700
inverters@solectria.com

SOLECTRIA SOLAR