



Integrating Utility Interactive Inverters into the Grid

A Case Study of EPRI/Yaskawa/Utility R&D under the DoE Sunshot Initiative Program and practical considerations

Introduction

The number of PV installations in the US for the last 5 years has been increased dramatically and the Solar Investment Tax Credit (ITC) extension in 2016 has set the stage for even more continuous growth of PV installations for years to come. After many years of subsidies and supportive strategic policies by federal and state governments, PV plants are now commercially competitive with the conventional generators with the additional benefit of presenting much fewer environmental concerns.

One major advantage of PV plants is that they are connected to distribution lines proximity to customer loads, which is desirable in that the generation loss can be minimized and there is no need for new line installations even with the load increasing. Another advantage of PV plants is the fact that they depend on the control of power electronics technologies which can provide fast and flexible protection and functions that increase the reliability of the grid which conventional rotating type generators cannot provide.

On the flip side, as PV penetration increases on the distribution network, the possibility of reverse power flow, overvoltage and increase in fault current need to be studied during the screening process of a PV plant. Utility companies often limit the generation to load ratio so that influence of PV plants to the grid can be controlled. Grid supporting functions such as power curtailment and reactive power control are used to solve such concerns and in many cases to increase the DER holding capacity in the feeders without risking the reliability of distribution service. The PV Industry and Yaskawa-Solectria Solar have used such grid supporting functions for several years. Figure 1 shows a 30MW PV plant installed in 2011 over 225 acres in Alamosa, Colorado using 504 Yaskawa-Solectria Solar PVI82kW inverters. These inverters are designed to provide fixed power factor, voltage regulation, constant reactive power and real power curtailment functions.



Figure 1. The world largest PV plant using concentrated PV in Alamosa CO

In order to control the power flow and plant terminal voltage, inverters were connected to the utility SCADA and generation of real and reactive power was adjusted in real time. Inverters were customized to meet the project based requirements, and the needs for standardized control functions and communication were just started to be discussed in the US PV industry.

Since 2011, Yaskawa, Solectria Solar has participated in the DoE Sunshot Initiative Solar Energy Grid Integration System (SEGIS) - Advanced Concepts, to demonstrate smart grid ready inverters with utility communication lead by the Electric Power Research Institute (EPRI) and in collaboration with several leading U.S. electric utility companies including National Grid (NGRID), Detroit Edison (DTE), Pepco Holdings, and Xcel Energy. The main objective was to implement state of the art grid supporting functions and communication with the existing inverters using industry standards, so that this developed technology could be adopted industry-wide.

After several years of development, deployment and demonstration, the project was successfully completed resulting in many technical and commercial accomplishments. As a result, the developed technologies have been adopted by Yaskawa-Solectria Solar and implemented into its products as optional functions. This article will discuss the test results of the field demonstration phase of the project and introduce practical considerations, operational strategy and commercialization of the technology.

Site Demonstrations

With the support from EPRI, NGRID, DTE and Pepco Holdings, two different series of Yaskawa-Solectria Solar PV inverters were tested at four different sites in Massachusetts, Michigan and New Jersey using the developed grid supporting functions. While several control strategies and demonstration scenarios were tested, this article will focus on the voltage regulation functions at the PV plants in Haverhill and Everett, Massachusetts.

1) Haverhill Site Preparation

The PV plant of consideration is located in a residential area of Haverhill, Massachusetts and generates 1MW of power using two Yaskawa-Solectria Solar SGI500, 500kW central inverters. This plant has been in operation since 2012 and was modified to demonstrate grid supporting features for the DoE Sunshot project. It is connected to a 13.2kV feeder and a substation 1.3 miles away. The short distribution feeder indicates low impedance of the feeder, which results in stiff voltage characteristics. There are one capacitor bank and a regulator at the substation for the voltage regulation of the feeder. Several different points along the feeder were monitored to evaluate how the reactive power generated by the PV inverters influences the longitudinal voltage profile.



Figure 2. PV Plant in Haverhill, MA: Residential area, short distribution line, Courtesy of EPRI and NGRID

The PV inverter hardware was modified to accommodate ride through operation at very low ac voltages and enable the industry standard DNP communication on the communications interface. The software modification also includes state of the art grid supporting functions including power factor control, fixed var control, volt-var, volt-watt, frequency-watt, abnormal voltage/frequency ride through, and dynamic reactive current support (DRCS). As a part of this research project, the site was modified to allow remote operation and data acquisition from utility controls using the industry standard DNP3 communication protocol as shown in Figure 3.

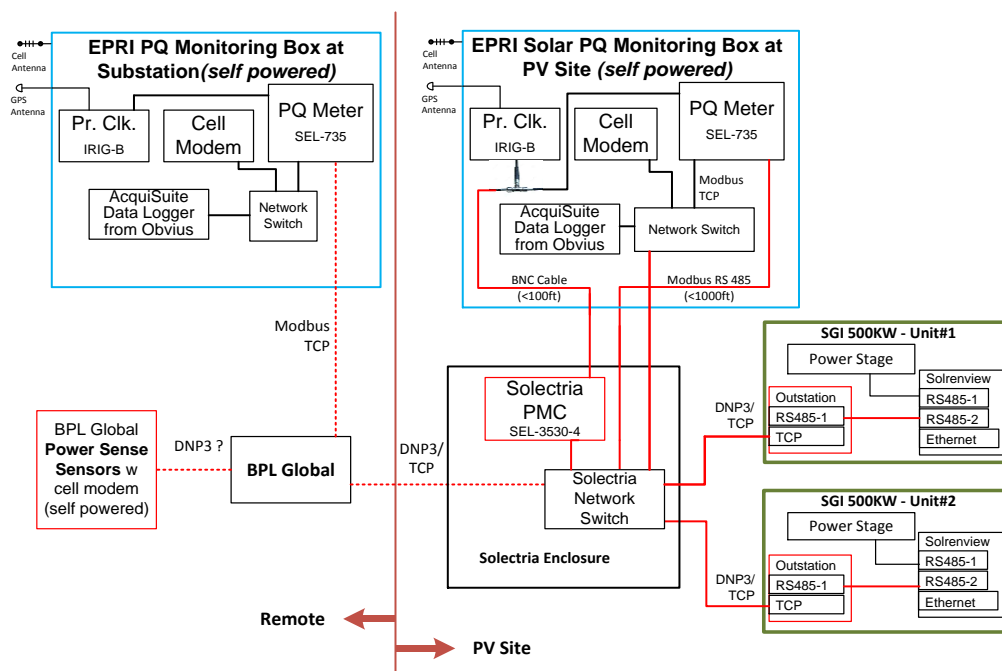

Figure 3. Communication and Monitoring Map of the PV Plant in Haverhill, Massachusetts

The DER management Solution (DERMS) from BPL Global, LLC, was used for utility side remote controller, which controls the PV plant for the planned operational strategies and interfaces with the data acquisition system for power monitoring. The Plant Master Controller (PMC) developed by Yaskawa-Solectria Solar was used as a data aggregator and a plant level supervisory controller, which received utility commands, distributed them to individual inverters at the plant, collected individual inverter information and sent the plant level operation status back to the utility controller. It can also serve as a master controller to enable coordinated operations using external equipment such as energy storage system, capacitor bank or voltage regulators.

2) Demonstration Scenario

One of the most important grid supporting functions of PV plants is the capability to minimize transient and steady state voltage flicker by providing reactive power to the grid. The self-induced voltage flicker caused by irradiation change can be mitigated effectively by simply controlling the power factor, which is presently done by many US utilities. The volt-var function is a more aggressive voltage control strategy that not only reduces the self-induced voltage flicker but also mitigates the voltage variation caused by external load changes on the feeder. For this reason, volt-var has been a target of industry standards for one of the mandatory grid supporting functions together with the power factor control. The volt-var function was studied extensively at the demonstration site to evaluate the practical effectiveness of the function.

The volt-var function regulates feeder voltage by injecting/absorbing reactive power using the reactive power capability of DERs. When the feeder voltage increases, the PV plant absorbs reactive power (an inductive operation) to pull down the voltage, and injects reactive power (a capacitive operation) when the voltage is reduced by heavy loads on the same feeder.

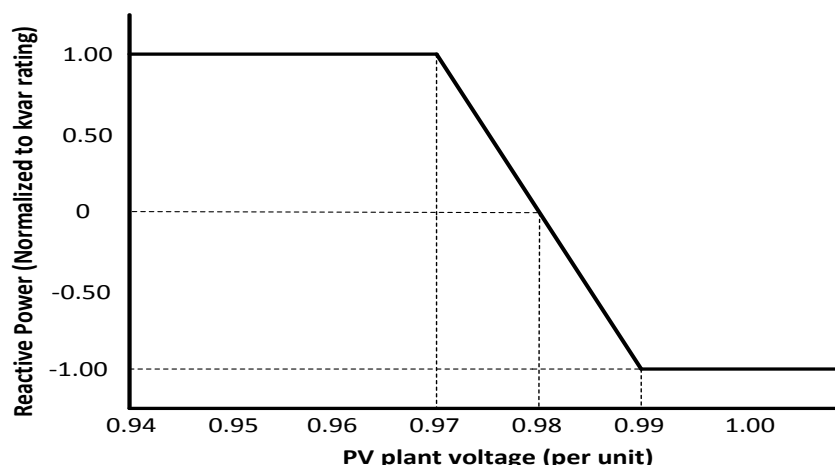

Figure 4. Volt-var control profile used for PV Plant in Haverhill, Massachusetts

For the field demonstration, a volt-var profile was defined as shown in Figure 4. The SGI inverter reactive power capability was set to 60% of its kVA rating, resulting in a maximum reactive power capacity for this site of $2EA \times 60\% \times 500kW = 600kvar$, which is normalized in the y axis of the curve. According to the curve defined by the figure, when the feeder voltage is at 0.98pu, the PV plant is expected to generate zero reactive power. When the voltage goes down to 0.97 pu, the PV plant generates its full rated reactive power to pull the voltage up. As the feeder voltage changes with applied reactive power, and as this control is a closed loop control in nature, the reactive power output is continuously being adjusted until regulation is achieved (to 0.98 pu) as long as the allowed reactive power is not limited.

This volt-var curve was chosen to maintain the feeder voltage level at less than nominal 1.00 pu so energy can be conserved, while remaining within the ANSI limit. For the purpose of evaluation, the volt-var function was enabled for 10 minutes and disabled for 10 minutes for the duration of several days in an alternating fashion. This approach of short operation intervals allows comparison of inverter operations with and without volt-var function at very similar weather conditions and distribution feeder load variations, minimizing the effect of these two important variables.

3) Volt-var Operation Results

Figure 5 shows the PV plant voltage with the volt-var function OFF(red) and ON(blue) over a full day operation. When the function was not enabled, inverters were generating power with unity power factor, so that the PV plant voltage was increased. The voltage fluctuation shown in red was caused by the irradiation changes and the load variations on the distribution feeder. As shown in the blue trace, the PV plant voltage was effectively regulated to about 272 volt, which corresponds to 0.982 pu. The voltage was maintained almost flat throughout the day, which indicates the voltage was not disturbed by the irradiation or load changes on the feeder.

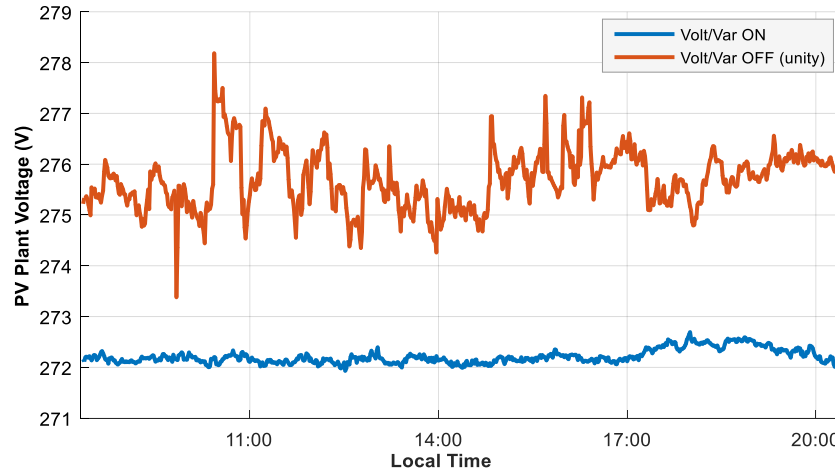

Figure 5. Haverhill PV plant voltage with and without volt-var function enabled, Courtesy of EPRI

Figure 6 shows the substation phase voltage of the 13.2kV feeder 1.3 miles away from the PV plant, which was also maintained relatively constant when the volt-var function was enabled. This indicates that even though the substation is away from the PV plant and connected to a relatively strong network, the substation voltage was influenced in a positive way by the reactive power generation change in the PV plant and the volt-var control.

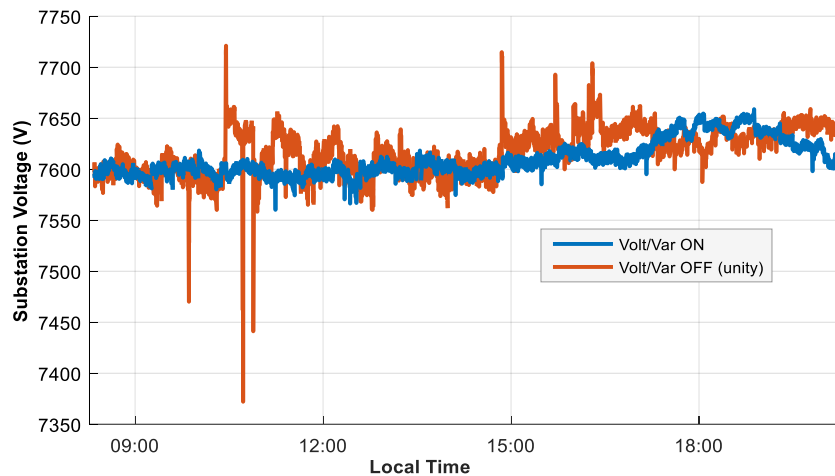

Figure 6. Substation voltage with and without volt-var function enabled, Courtesy of EPRI

The voltage profile along the feeder is shown using the box and whiskers plot in Figure 7. In general, the range of both the box (2nd and 3rd quartiles) and the whiskers (minimum and maximum) with the volt-var function enabled is narrower, which indicates the effectiveness of voltage regulation of the volt-var function.

Obviously the voltage regulation at the PV plant was the most effective with minimum ranges in the box and whiskers plot. The substation voltage variation range was naturally smaller than other points in the feeder because it is connected to a strong network or transmission line. As the voltage sensing point moves away from the PV plant, the range of the box and whiskers increases, which proves the reactive power does not travel far and is mostly consumed at the point of regulation.

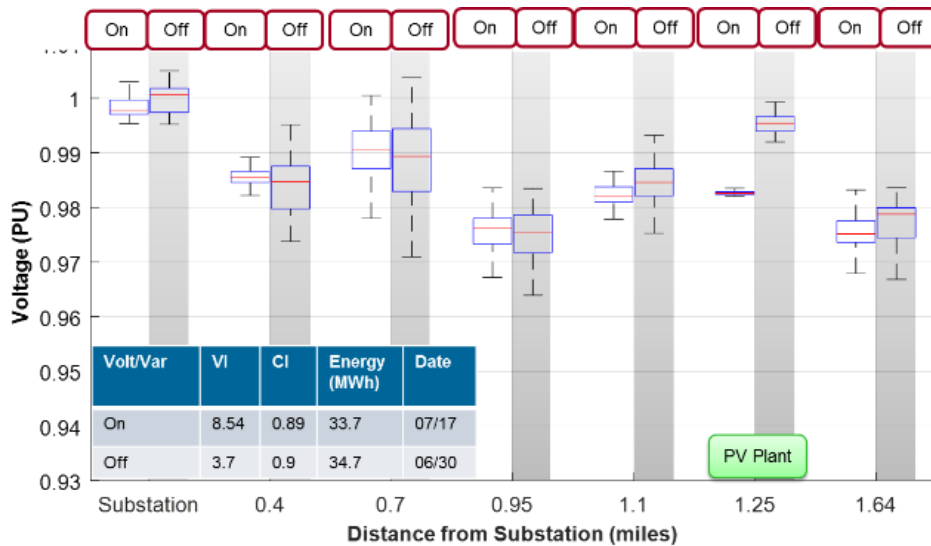

Figure 7. Voltages along the Haverhill feeder with and without the volt-var function, Courtesy of EPRI

Figure 8 shows the control characteristics of the volt-var function at the Haverhill site. The green curve is the desired volt-var characteristics, the blue dots are the data points after the test, and the red trace is the trend line of the blue data points. As is shown, the feeder voltage ranged between 0.978 to 0.985 and aligned to the assigned graph with a minor offset, which indicated that the function operated well according to the assigned voltage profile.

At Haverhill, the PV plant absorbed the reactive power to lower the voltage to the target value, so that the data points were distributed on the lower part of the figure. There was a slight mismatch between the assigned volt-var characteristic curve (green) and inverter operation (red). The voltage sensing tolerance in the PV inverter can generate this type of offset mismatch. However, considering the 1~2% tolerance in voltage sensing in the industry, the result shown is better than the industry standard.

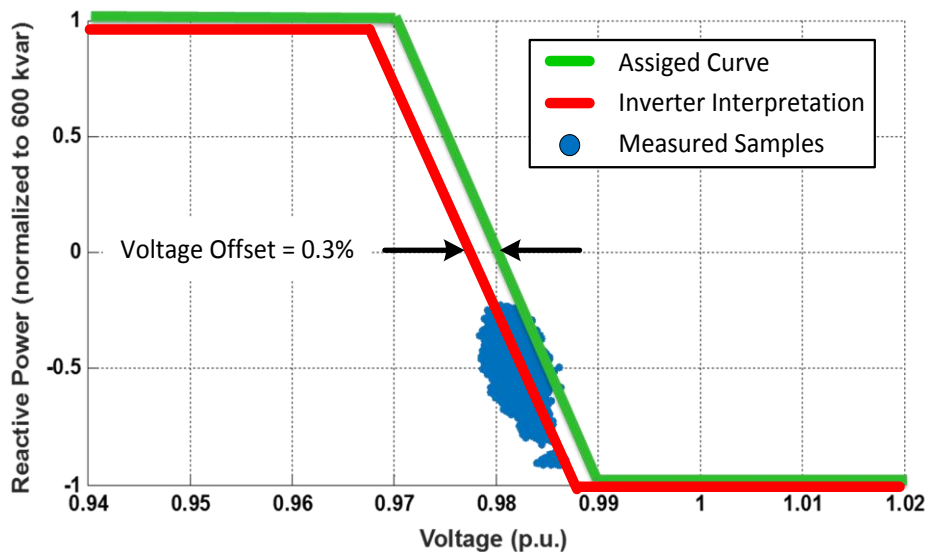

Figure 8. Voltages at the Haverhill PV Plant with and without the volt-var function, Courtesy of EPRI

Practical Considerations

After testing various grid supporting functions at multiple sites, several characteristics were monitored, that can be used to develop operational strategies of the PV plants in the distribution line and/or to investigate options in the planning stage or during impact studies.

1) Voltage regulation to increase the penetration level

The volt-var function is effective in regulating the inverter terminal voltage as is shown in the previous section. Similar control effectiveness could be achieved with power factor control. Figure 9 shows the voltage distribution at a PV plant in Cedarville, New Jersey. Initially, the feeder voltage increased higher than 1.05pu as the PV plant generation increased. The utility company, Pepco Holding, had to prohibit additional PV installations in that feeder and study options for a control strategy to reduce the overvoltage. Finally, they decided to set the power factor of the PV plant at 0.97 inductive and were able to achieve voltage regulation as shown on the right side of the figure. The flat voltage profile over the full PV generation ranges (right) indicates that the feeder voltage was not influenced by irradiation changes. The vertical distribution of voltage in both traces was caused by the feeder load changes, which power factor control does not compensate for.

This solution was possible by a minor software modification without additional equipment in the feeder or hardware modification in the PV inverter. Moreover, with the stabilized voltage profile, Pepco Holdings decided to host additional PV plants on the same feeder.

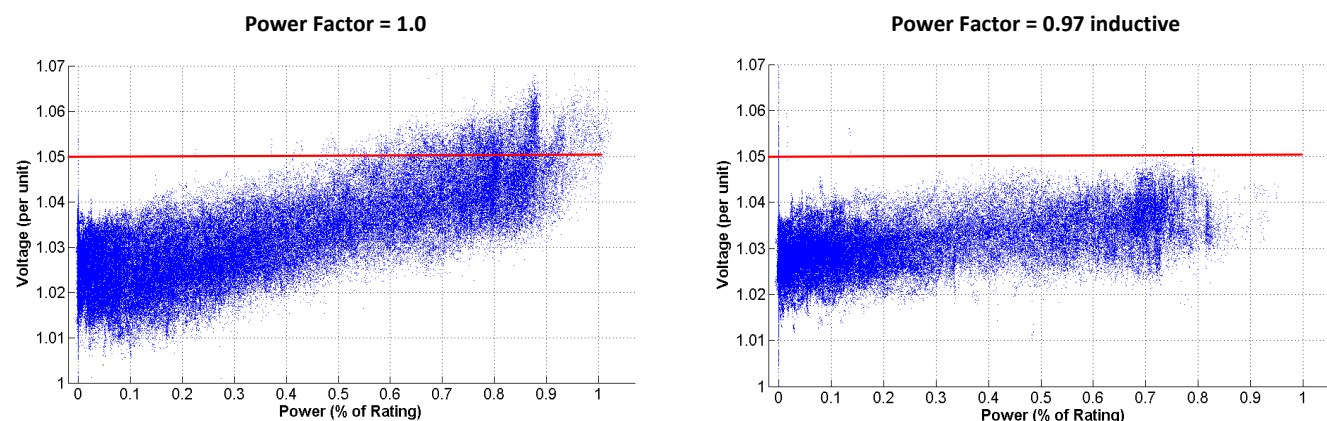

Figure 9. Voltage Regulation by using power factor control: Cedarville New Jersey, Courtesy of Pepco Holdings

The required power factor is largely dependent on grid impedance, and is usually higher than 0.95, so this control is practical without noticeable reduction in power generation. Currently, many utility companies in the U.S. use power factor control on PV plants for the same purpose. In Hawaii, there exists a new mandate to have an inductive power factor at 0.95 for all PV plants.

Volt-var and power factor control functions are used for the same purposes. Even though volt-var control is more aggressive in controlling the voltage since it compensates the voltage variation due to load change, the characteristics of the functions are similar and can be summarized as follows:

- They compensate for the voltage fluctuations during the steady state as well as during the transient. The voltage flicker caused by irradiation change is being compensated very effectively.

- During normal operation, the generation loss due to these controls is less than a fraction of a percent. Instead, the PV plant hosting capacity of a given feeder can increase by more than 10%. Therefore, the coordinated control can be necessary for areas with high DER penetration.
- These controls are autonomous within the PV inverter, and thus do not require additional hardware modifications or communication requirements. This provides an economical solution for voltage regulation with high reliability.
- A conventional PV plant with unity power factor can increase the voltage flicker caused by irradiation changes, which in turn increases the number of operations of the regulators and capacitor banks. The power factor and volt-var control compensate the voltage effectively and will reduce the number of those ancillary service operations and the associated wear out of the equipment.

2) Weather Dependent Resources

Figure 10 shows the inverter operation in Haverhill PV site to control the power factor at the substation. With the operation of two inverters, the power factor of the substation is maintained to be unity during the daytime.

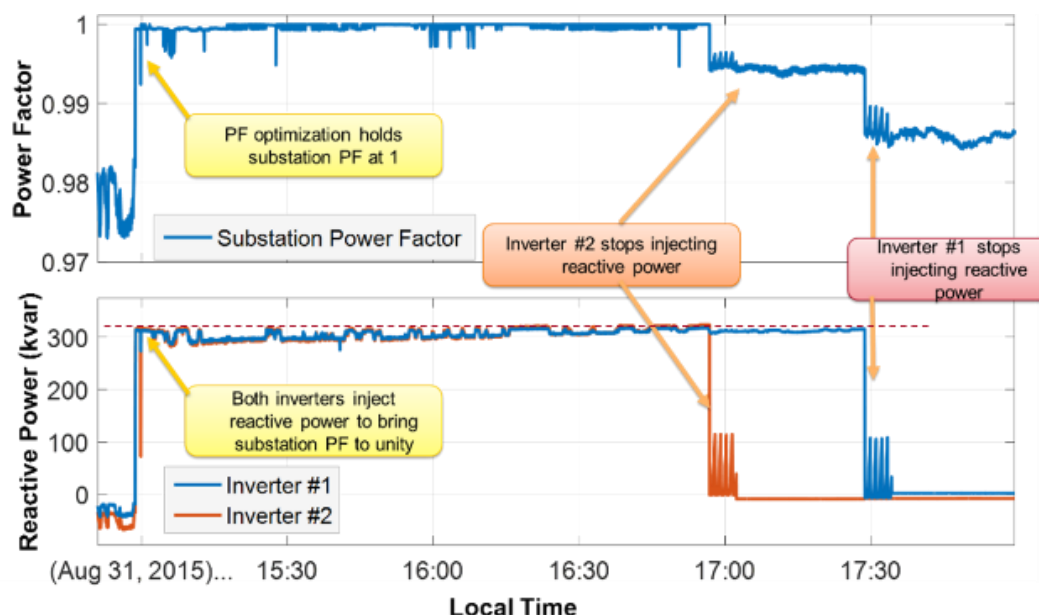

Figure 10. Power Factor Control at the Haverhill Massachusetts PV plant, Courtesy of EPRI

At around 5 pm in Figure 10, the reactive power output of inverter #2 (South facing array) went to zero while inverter #1 was still operating, thereby the power factor was reduced slightly. Inverter #2 turned off because of low irradiation; and inverter #1 shut down at around 5:30 pm (West facing array). The several pulse flickers before the reactive power went to zero for the night are the signatures of 'shut down and trying to restart' operation at sunset as the irradiation level approached inverter turn on/off threshold.

Figure 11 shows the Haverhill site PV array tables with different tilt angles. This angle difference generated a 30 minutes gap between two inverter shut-down operations. This type of uneven turn-off is not rare and will be even more obvious if there are multiple PV plants with different installation characteristics on different feeders of one substation.

For the same reason of weather dependency, power factor control of a substation should not be solely dependent upon PV plants but also dependent on the lack of inverter operation at night. This is an obvious limitation of a PV plant used as ancillary equipment for voltage regulation. In order to overcome this, PV plants can be coordinated with capacitor banks to regulate power factor throughout a full 24 hours. In the future, night time operation of the PV inverter can be considered. The technology is available; and its implementation can be achieved with some modifications.



Figure 11. PV Panel Installation with different tilt angle at Haverhill site

3) Designing a volt-var curve

As briefly discussed in the previous section, a volt-var curve should be defined specifically for each PV plant taking existing feeder characteristics into consideration. Figure 12 shows two volt-var curves and test results during the demonstration period. It can be noticed that the regulation voltages were not set to 1.0 pu to prevent saturation of the reactive power outputs.

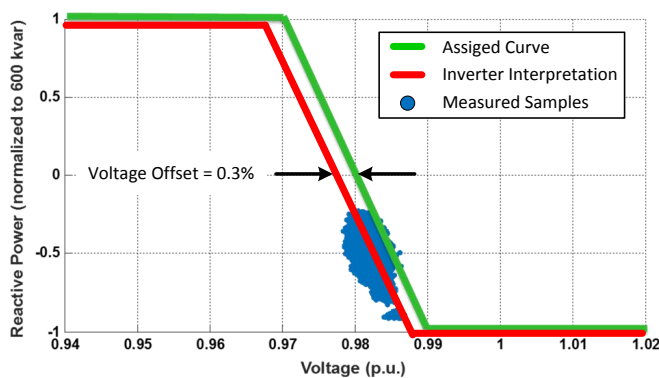

a) Haverhill PV Plant

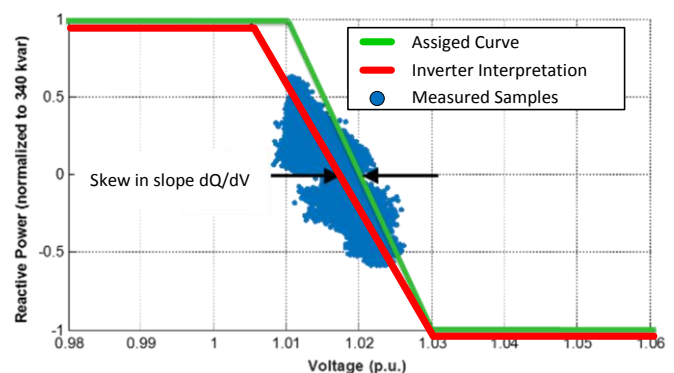

b) Everett PV Plant

Figure 12. Two volt-var curves and test results with different characteristics, Courtesy of EPRI

The reactive power ranges (span of blue dots on the y-axis) were less than the PV plant reactive power capacities, showing the PV inverters had enough capacity margins to perform voltage regulation. The reactive power output of the Everett site spanned evenly from -0.5 to 0.5 pu centered at zero, which means the inverters at the site did not need to limit the real power generation much in order to achieve the required var output. In contrast, the reactive power output was biased from -0.9 to -0.3pu. Although it is still acceptable, a better curve for Haverhill site to maximize the real energy harvest would be to shift the curve slightly to the right and set the regulation voltage to 0.983, which would move the reactive power output to around -0.3 to 0.3pu.

The magnitude of the scheduled voltage and the stiffness of the feeder also played an important role in defining the curve. For example, the midpoint voltage was set to 0.98 for the Haverhill site and 1.02 for the Everett site. These set points were close to the scheduled voltage by the utility, and could be adjusted based on the time of the day, season or load/generation forecast information. For this purpose, the volt-var control was coordinated with the utility SCADA through an industry standard communication protocol.

	Haverhill PV Plant	Everett PV Plant
Midpoint voltage	0.98	1.02
dQ/dV (var/V)	4,500	6,800
Reactive power range	Biased on negative	Evenly distributed

Table 1. Volt var curve characteristics

Another minor observation was that there was a slight mismatch between the planned volt-var curve and the PV plant reactive power output. This could be caused by the voltage sensing offset (Haverhill) or a slope error (Everett) from the sensing circuit tolerance of the equipment, that was discussed previously. In the planning phase, the manufacturer’s stated accuracy and industry standard requirements should be taken into account.

4) Plant Level Operation

When there are multiple inverters at a large PV plant, plant level control may be desirable to ensure a coherent operation and that the inverter output is evenly distributed. Plant level control is also desirable when some inverters are in maintenance service or malfunctioning; in this situation, the remaining inverters can achieve the required function by sharing the control burden.

The plant level power factor control at the remote substation mentioned previously is a good example. The volt-var is programmed in each inverter as an autonomous function. However, the actual outcome of the function is similar to plant level control. Figure 13 shows test results at the Haverhill site.

When the volt-var function was enabled for both inverters, the two inverters shared reactive power outputs. The difference in the reactive power output could have been caused by differences in voltage and current sensing tolerances. There could be cases in which one inverter generates reactive power while the other inverter does not. This could be caused by communication errors. The output reactive power of the functioning inverter in this case was the sum of the two inverter output reactive power in the previous stage as shown in Figure 13.

One inverter generated the expected reactive power but the terminal voltage was not regulated, resulting in the inverter generating the reactive power that the other inverter should have supplied. In conclusion, volt-var function has the characteristics of a self-compensation effect even with an inverter malfunction.

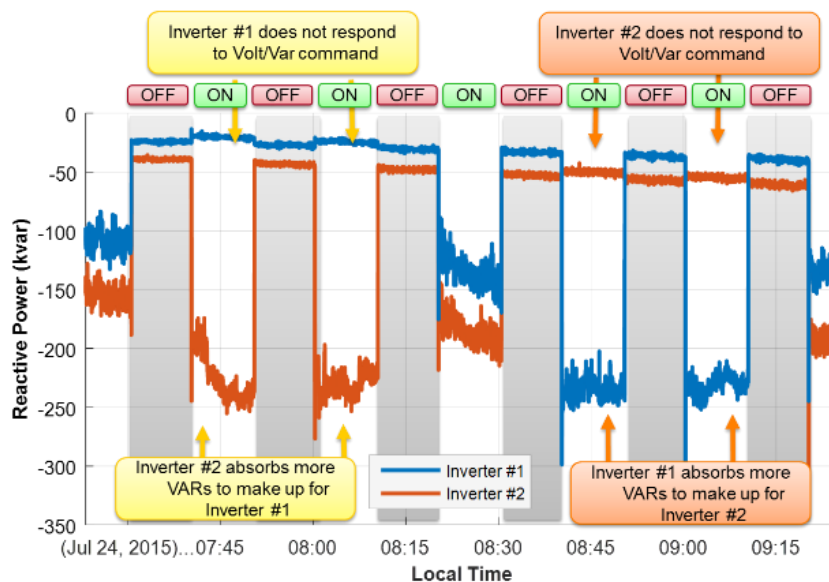

Figure 13. Volt-var operation of two inverters with a communication concerns, Courtesy of EPRI

Commercialization

The DoE project under the Sunshot Initiative advanced the development of software functionalities that can be adopted into existing Yaskawa-Solectria Solar products. Although the scope of the project was defined back in 2011, it included all grid supporting functions defined in CPUC Rule 21 Phase 1 in 2014, and more than 80% of the functions that will be mandatory in the US under the new IEEE1547 standard to be published in 2018.



Figure 14. 1.0MW PV plant with grid supporting functions in Shirley, MA

Even before the research project was officially closed, Yaskawa-Solectria Solar was able to deploy the developed functions into commercial products and they are currently installed at several PV plants in Massachusetts. Commercialization was possible due to industry pressure to solve high penetration issues and the associated need for the advanced grid supporting functions. Figure 14 shows two SGI 500kW XTM central inverters installed at Shirley, Massachusetts on a separate project done with National Grid. The inverters are equipped with state of the grid supporting functions including voltage/frequency ride through, volt-var, power factor, and slew rate control.

In order to commercialize this derivative product, Yaskawa worked closely with National Renewable Energy Laboratory (NREL) in Golden Colorado. Since new functions need to meet certain performance criteria and dynamic requirements, the inverters needed to be tested at full power with different normal and abnormal grid conditions and panel voltages. The ESIF in Golden, Colorado is one of the few test facilities in the US that can host full power test of large PV inverters with different grid abnormal grid conditions.

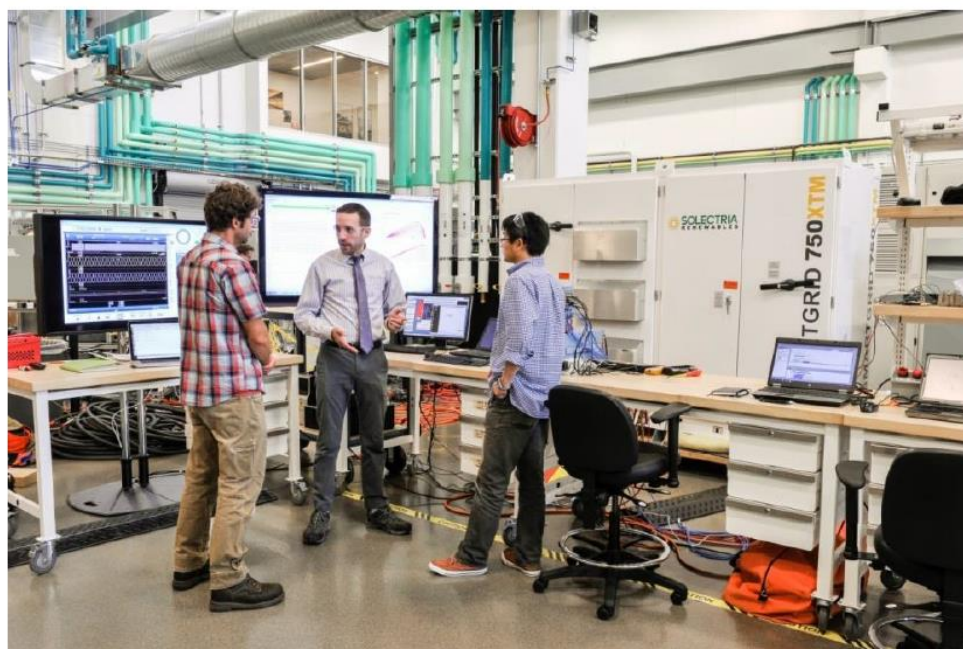

Figure 15. SGI XTM inverter testing at ESIF, NREL

Summary

This article introduces PV inverter grid supporting functions developed under the DoE Sunshot Initiative Program. The functions were embedded into Yaskawa-Solectria Solar PV inverters at several PV plants to evaluate functionalities of the grid supporting function. Test results are analyzed taking operational strategies and grid characteristics into account.

This article is focused on the voltage regulation aspect of the grid supporting functions intended to mitigate voltage flicker caused by the intermittent nature of PV plants or load changes. Field test results showed very promising regulation effects and introduced several practical choices that can be evaluated during PV plant planning stages.

Finally, the article introduces a new Yaskawa-Solectria Solar XTM inverter series which includes the grid supporting functions developed during this DoE project. This new XTM inverter series has been launched in the U.S. market in early 2015 even before this DoE research project was finished and the developed grid supporting functions are currently being used in many PV plants throughout the U.S.

Reference

EPRI Document No. 3002008557 “Smart Grid Ready PV Inverters with Utility Communication: Results from Field Demonstrations’ published May 26, 2016