

Application Note

Interconnection Guidelines for Yaskawa Solectria Solar XGI 1500-DCG Inverters

XGI 1500-DCG Models

XGI 1500-250/250-600-DCG

XGI 1500-225-600-DCG

XGI 1500-200/200-480-DCG

XGI 1500-175-480-DCG

Yaskawa Solectria Solar's XGI 1500-DCG inverters provide a DC negative ground, and require AC output connection to a wye-configured service with a floating neutral (see Figure 1), or an ungrounded delta. The XGI inverter uses Neutral for AC voltage sensing, when a Neutral is available. Acceptable service configurations are depicted in the Figure 1 below.

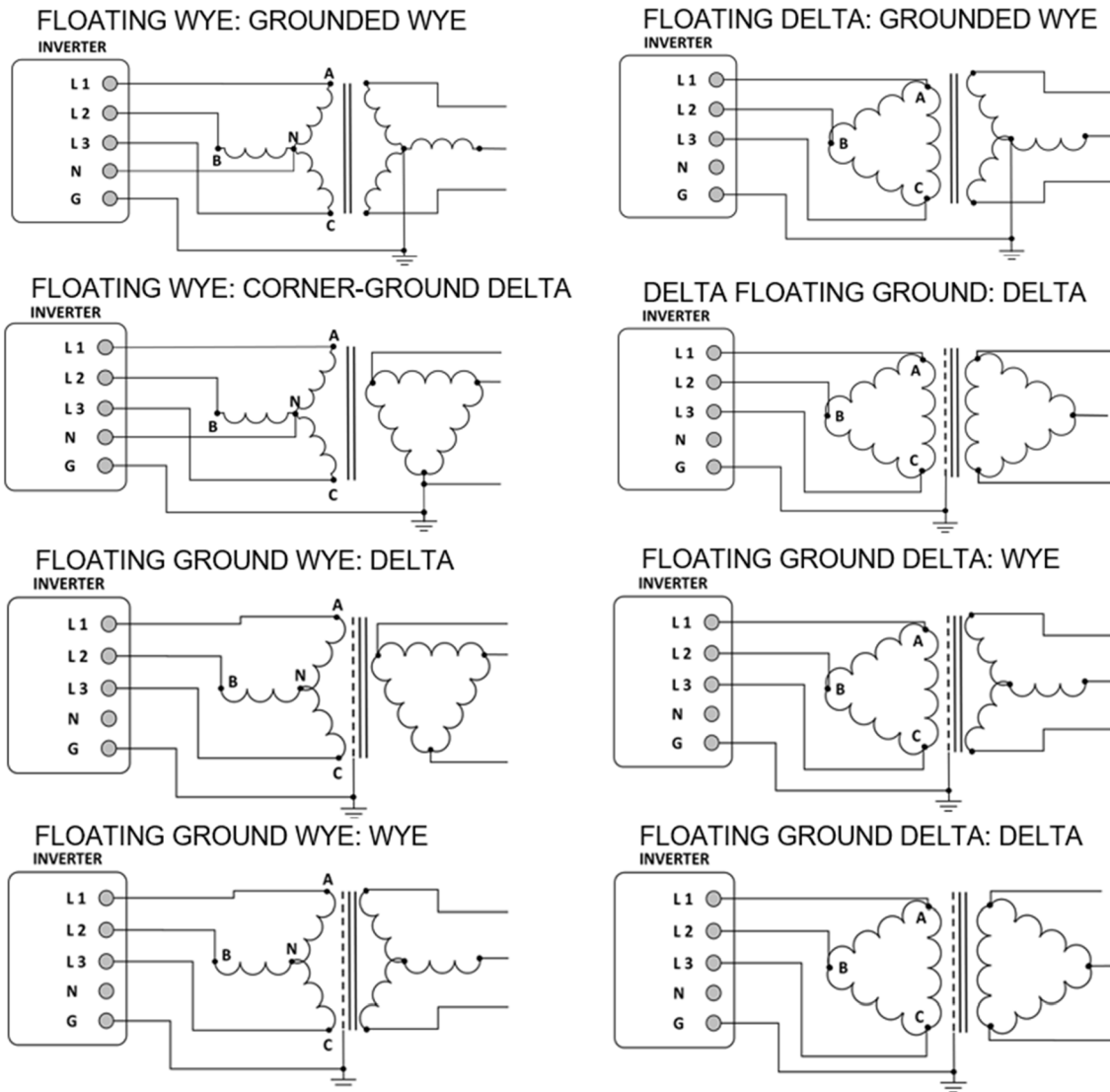

Figure 1. Permitted Transformer Configurations for XGI 1500-DCG Interconnection

INFO →	<p>Maximum Number of Inverters on a Transformer Winding</p> <p>Connect no more than eight (8) XGI 1500-DCG inverters to the same winding of a transformer. Up to 16 XGI 1500-DCG inverters can be connected to a transformer with dual windings, with no more than 8 inverters per winding. All other connections, such as for site loads (lighting, metering, etc), must be galvanically isolated from the inverters. See the <i>External Transformer Specification Guide</i> for the XGI 1500-DCG inverters at the end of this document.</p>
---------------	---

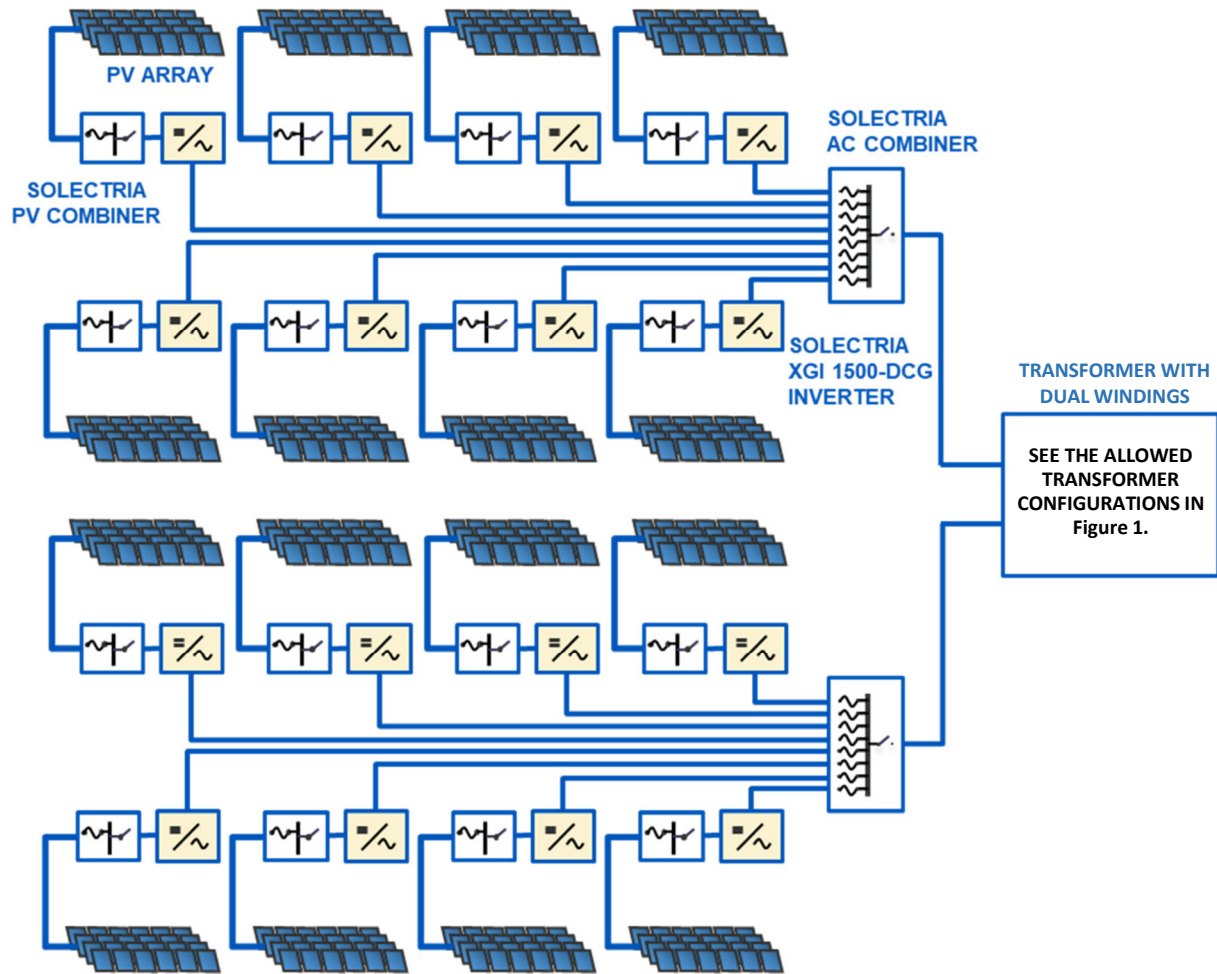

Figure 2. Maximum number of XGI 1500-DCG inverters per transformer winding

No more than 8 XGI 1500-DCG inverters, in parallel, may be connected to a single winding of a transformer, to ensure proper functioning of the GFDI functionality. Up to 16 XGI 1500-DCG inverters may be connected to separate windings of a dual-winding transformer, with a maximum of 8 per winding, as in Figure 2.

Transformer Specification Guide

For XGI 1500-DCG Compatibility

1 Intended Audience

This specification is intended to guide the solar system designer in choosing the correct medium-voltage transformer.

2 Applicable XGI 1500 Inverter Models

- XGI 1500-250/250-600-DCG
- XGI 1500-225-600-DCG
- XGI 1500-200/200-480-DCG
- XGI 1500-175-480-DCG

(Note: this family of inverters is referred to, collectively, as the *XGI 1500-DCG* models in this guide)

NOTICE

Up to 8 inverters of the XGI 1500-DCG type can be paralleled on the same transformer winding. Up to 16 XGI 1500-DCG inverters can be connected to a transformer with dual windings, with no more than 8 inverters per winding.



WARNING

No other non-isolated loads are allowed to be connected in parallel with the XGI 1500-DCG inverters on the transformer windings.

3 Specification



WARNING

This document establishes the general guidelines to selecting the correct external transformer to work in conjunction with Yaskawa's XGI 1500-DCG inverters. Many more transformer parameters are project specific (e.g. transformer efficiency, protection, kVA level, medium voltage level, etc.) and vary from case to case. **Please submit your complete transformer specification together with the project single line diagram for review by the Solectria Application Engineering team.**

3.1 Transformer Type and Specifications

- The transformer shall be three phase.
- The transformer shall be oil cooled.
- The transformer shall be UL listed.
- Pad mount, distribution-type transformers shall comply with the latest issue of IEEE/ANSI C57.12.34.
- The LV windings shall be 600V (or 480V, as needed) ungrounded delta or ungrounded wye.
- There shall be taps at -5%, -2.5%, +2.5% and +5%.
- The HV windings shall be WYE (grounded or floating) or Delta (floating or corner-grounded).
- Transformer shall operate at 60Hz nominal and shall be tolerant of continuous frequencies between 57.0Hz and 62Hz.
- Transformer shall be capable of operating at 1.1 p.u. voltage at full load without saturation for periods of time typical of the expected generation profile.

3.2 Transformer Rating

- 250kVA - 2.0MVA, 5.75%-7.5%IZ @ 85%, 65C rise.

3.3 Construction

- The core and coil shall be vacuum processed to ensure maximum penetration of insulating fluid into the coil insulation system. While under vacuum, the windings will be energized to heat the coils and drive out moisture, and the transformer will be filled with preheated filtered de-gassed insulating fluid.
- The core shall be manufactured from burr-free, grain-oriented silicon steel and shall be precisely stacked to eliminate gaps in the corner joints.
- The coil shall be insulated with B-stage, epoxy coated, diamond pattern, insulating paper, which shall be thermally cured under pressure to ensure proper bonding of conductor and paper.
- Coils shall be either aluminum or copper.
- The tank shall be complete with an anodized aluminum laser engraved nameplate. This nameplate shall meet Nameplate B per ANSI C57.12.00.
- Clamp-type tank grounding connections shall be provided for pad mount distribution transformers in accordance with ANSI C57.12.34.
- A primary switch shall be provided.
- Externally-mounted, Distribution Class M.O.V.E. dead-front elbow arrestors shall be supplied.