

Commercial 1000VDC String Inverters

Solectria® PVI 25TL-208

Solectria® PVI-36TL-480-V2

Solectria® PVI 50TL-480

Solectria® PVI 60TL-480

Installation and Operation Guide

Listing File Model: PVI 25TL-208
 PVI-36TL-480-V2
 PVI 50TL-480
 PVI 60TL-480



- 1. Document Modification History 4
- Before You Start..... 5
- 2. Important Safety Instructions 6
 - 2.1 Hazard Symbols..... 6
 - 2.2 Symbols on Labels..... 7
 - 2.3 General Safety Messages..... 7
- 3. Overview 10
 - 3.1 Intended Use..... 10
 - 3.2 Inverter Features 11
 - 3.3 Inverter Protections..... 12
 - 3.4 Smart Inverter Functions (default state) 12
 - 3.5 Inverter Diagrams 13
 - 3.6 Schematic Diagram and Circuit Design 15
 - 3.7 Anti-islanding Detection 17
 - 3.8 DC Ground Fault Protection..... 17
 - 3.9 Surge Suppression..... 17
 - 3.10 DC Arc-fault Protection..... 18
 - 3.11 Module-Level Rapid Shutdown..... 18
 - 3.12 Communication Overview 18
 - 3.13 Labels 19
 - 3.14 Unpacking 20
- 4. Installation 20
 - 4.1 Installation Sequence Overview 23
 - 4.2 Mechanical Installation..... 24
 - 4.3 Electrical Installation..... 39
 - 4.4 Communication Installation..... 60
 - 4.5 Communication Wiring 63
- 5. User Interface 64

- 5.1 Description of the Interface.....64
- 5.2 Operation State.....66
- 5.3 Interface Types66
- 6. Commissioning.....68
 - 6.1 Commissioning Checklist68
 - 6.2 Commissioning Steps.....69
- 7. Menu Functions72
- 8. Fault Shutdown and Troubleshooting103
 - 8.1 LED Status Panel Testing.....103
 - 8.2 LCD Fault and Troubleshooting.....104
- 9. Maintenance and Decommissioning of Inverters.....113
 - 9.1 Product Maintenance114
 - 9.2 Uninstall the Inverter.....118
- 10. Accessories.....118
 - 10.1 Fuse Bypass Terminals118
 - 10.2 Shade Cover Kit (MTLSR-070551)121
- 11. Technical Data.....124
 - 11.1 Datasheet.....124
 - 11.2 Measurement Tolerances126
 - 11.3 Production Graphs127
- 12. Appendix136
 - 12.1 Warranty and RMA Instructions136
 - 12.2 Datasheet.....136
 - 12.3 Contact Information136

1. Document Modification History

DATE	VERSION	SECTION	MODIFICATION	BY
2022 OCT 07	A		Creation of document. Labeled DRAFT	ECH/HA
2024 JAN 15	B	All 4 10	DOCR version changed from DOCR-071030-A to DOCR-071086-B Addition of water ingress issues in regards to warranty. Removal of PVI 25TL-208 fuse bypass capability.	ECH ECH ECH
2024 APR 12	C	4	Removal of PVI 25TL-208 fuse bypass capability	ECH

Before You Start



This manual contains important information regarding installation and safe operation of the PVI 25TL-208 and the PVI-36TL-480-V2 & PVI 50/60TL-480 and is intended for qualified personnel only. Qualified personnel having training, knowledge and experience in:

- Installing electrical equipment and PV power systems (up to 1000VDC).
- Applying all local installation codes.
- Analyzing and eliminating the hazards involved in performing electrical work.
- Selecting and using Personal Protective Equipment (PPE).

Installation, commissioning, troubleshooting, and maintenance of the inverter must be done only by qualified personnel. Be sure to read this manual carefully before using the inverter.

Thank you for choosing a Yaskawa Solectria Solar grid-tied PV inverter. This PV inverter is a high performance and highly reliable product specifically designed for the North American Solar market.

If you encounter any problems during installation or operation of this unit, first check the user manual before contacting your local dealer or supplier. This user manual is applicable for the following models: **PVI 25TL-208, PVI-36TL-480-V2, PVI 50TL-480 & PVI 60TL-480.**

Instructions inside this user manual will help you solve most installation and operation difficulties. Contact your local supplier if the problem still exists.

Please keep this user manual on hand for quick reference. Always check online for an updated version of this product manual. The contents of this document are subject to change without notice.

2. Important Safety Instructions

SAVE THESE INSTRUCTIONS

This manual contains important instructions for models:

PVI 25TL-208

PVI-36TL-480-V2

PVI 50TL-480

PVI 60TL-480

Please read this user manual carefully before installation of the inverter. Yaskawa Solectria Solar reserves the right to refuse warranty claims for equipment damage if the user fails to install the product according to the instructions in this manual. Failure to follow these instructions and other relevant safety procedures may result in voiding of the product warranty and/or damage to the inverter or other property.

2.1 Hazard Symbols



Indicates a hazardous situation, which, if not avoided, will result in death or serious injury.



Indicates a hazardous situation, which, if not avoided, could result in death or serious injury.



Indicates a hazardous situation, which, if not avoided, could result in minor or moderate injury.















Indicates a hazardous condition, which, if not avoided, could result in property damage.



Indicates important supplementary information to use the product effectively.

2.2 Symbols on Labels

Table 2-1 Explanation of Symbols on Labels

SYMBOL	DESCRIPTION
	DC Signal
	AC Signal
	Equipment Ground
	Phase
	Off
	On
	Refer to Operating Instructions
	Caution: Risk of Electric Shock Do not remove cover until 5 minutes after disconnecting all supply sources
	Caution: Risk of Electric Shock Timed Discharge
	Caution: Hot Surface Do Not Touch
	Warning: Hazardous voltage area under plastic cover. Do not open fuse holders under load. Proper PPE must be used while accessing fuses. For continued protection against risk of fire, replace only with same make and type of fuse.
	Information: For more information, please see the installation and operations manual

2.3 General Safety Messages

 **DANGER**

Electric Shock Hazard: Components with hazardous voltage and energy will electrocute operator. Operator shall avoid touching live components with hazardous voltage and energy.

Operator may contact components with hazardous voltage and energy. Use proper safety equipment including Personal Protective Equipment (PPE) when de-energizing the unit. De-energize both the AC and DC power from the unit, wait 5 minutes, and verify the absence of voltage before opening the equipment or removing any protective shields.

WARNING

Unqualified Operator Hazard: Operator may cause a hazardous situation by making incorrect installation or wiring connections. A qualified technician shall do all installation and wiring connections to comply with all local, national, and country specific guidelines for safety.

Risk of electric shock and fire: Use only with PV modules that have a maximum system voltage of rating of 1000VDC or higher

Electrical Shock Hazard: The DC conductors of this photovoltaic system are normally ungrounded but will become intermittently grounded without indication when the inverter performs the PV array isolation measurement.

Chemicals Hazard: This product can expose you to chemicals including lead, known to the State of California to cause cancer and birth defects or other reproductive harm. For more information, go to www.P65Warnings.ca.gov.

CAUTION

Heavy Lifting Hazard: Solectria PVI 25TL-208, PVI-36TL-480-V2, PVI 50TL-480, and PVI 60TL-480 inverters weigh 56 kg (123.5 lbs). The wiring box weighs 15 kg (33 lbs). Ensure the mounting bracket is properly installed prior to hanging the inverter and wiring box on the bracket. A team of more than two is recommended to lift and place the inverter and wiring box into position.

NOTICE!

General Damage to Equipment: Attempting to service the inverter improperly may result in damage. Contact Yaskawa Solectria Solar Technical Support for maintenance.

Use as Intended: Solectria PVI 25TL-208, PVI-36TL-480-V2, PVI 50TL-480, and PVI 60TL-480 inverters are designed for PV grid-tied systems. The inverters are to be installed with floating or ungrounded PV arrays only.

INFO ✓

Read and Follow Instructions: Failure to read and follow instructions may void the warranty. Install the inverter according to the instructions in this manual.

Grid Standard: Please check with the local electric utility supply company before selecting a grid standard. If the inverter is operated with an incorrect grid standard, the electric utility supply company may cancel the

interconnection agreement. Placing the inverter into operation before the overall system complies with the national codes, rules and safety regulations of the application is not permitted.

If there is a fault; and it is safe to access the inverter:

1. Read/record the fault code(s) displayed on the LCD interface.
2. Turn OFF the inverter via the LCD/Keypad or Remote access.
3. Turn OFF the AC feed breaker.
4. Turn OFF the AC Switch.
5. If possible, read the DC MPPT currents displayed on the LCD interface:
 - a. If the MPPT current is $<20A$ or the irradiation is obviously low, turn OFF the DC switch.
 - b. If it is safe to open the wiring box, proceed with troubleshooting procedures listed in Table 8-1. Make sure appropriate safety precautions and PPE are used.
6. If it is not possible to read the DC MPPT currents through the LCD interface, and no fire, smoke, or voltage (AC or DC) to ground is present in the enclosure:
 - a. Follow general safety practices including PPE to open the wiring box.
 - b. Measure the DC current on each string. If zero, open the fuse holder for each string reading approximately zero amps.
 - c. If the DC current is $>0.25A$, do not open the fuse holder.
 - d. When all possible fuses are open, measure the total MPPT current. If it is $<20A$, turn OFF the DC switch.
 - e. If turning OFF the DC switch causes smoke, then (if safe) turn the DC switch back ON and wait until low irradiance $\sim 30\text{min}$ prior to sunset to continue troubleshooting.

If there is a fault and it is unsafe to access the inverter:

1. Notify someone else. Initiate emergency mitigation plan if necessary.
 - a. If smoke or fire exists, procure a fire extinguisher.
2. If a fire has escaped the inverter enclosure – call 911 immediately!
3. Turn OFF the AC feed breaker as soon as possible/safe.
4. If safe but conditions are deteriorating, consider:
 - a. Using the fire extinguisher.
 - b. Cutting the string conductors – one cable at a time with insulated cutters (while wearing appropriate PPE).

5. Monitor conditions until low irradiance ~30min prior to sunset. If safe, turn OFF AC and DC switches on the inverter and proceed with normal troubleshooting procedures listed in Table 8-1.

3. Overview

3.1 Intended Use

The SOLECTRIA PVI 25TL-208, PVI-36TL-480-V2, PVI 50TL-480, and PVI 60TL-480 are grid-tied, photovoltaic (PV), three-phase inverter, suitable for use in commercial or utility-scale installations. The SOLECTRIA PVI 25TL-208, PVI-36TL-480-V2, PVI 50TL-480, and PVI 60TL-480 inverters are an integral part of a typical PV installation, which typically includes PV modules, DC power distribution equipment, a PV inverter, and AC power distribution equipment. The SOLECTRIA PVI 25TL-208, PVI-36TL-480-V2, PVI 50TL-480, and PVI 60TL-480 inverters convert solar power (DC) to AC power suitable for use in buildings and back feeding onto the electrical grid. This inverter is a grid following inverter, which means it synchronizes the output current with the voltage waveform of the grid. The SOLECTRIA PVI 25TL-208, PVI-36TL-480-V2, PVI 50TL-480, AND PVI 60TL-480 inverters are an ideal product for use in rooftop, carport, or ground mount installations where quality and performance are paramount.

The SOLECTRIA PVI 25TL-208, PVI-36TL-480-V2, PVI 50TL-480, and PVI 60TL-480 inverters are not intended for use in a micro-grid or off-grid application. Although successful integration into AC-coupled storage systems is possible, Yaskawa Solectria Solar does not support or provide guidance for use in this type of application.

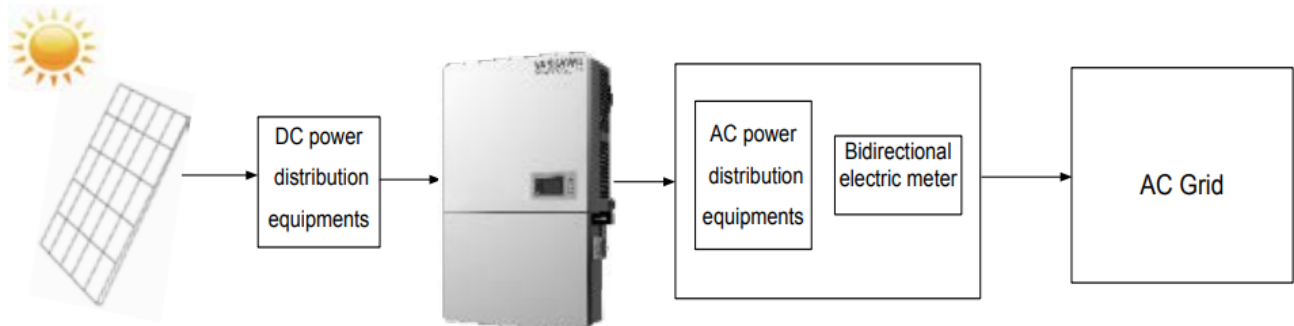

Figure 3-1 Grid-Tied PV System

3.2 Inverter Features

	PVI 25TL-208	PVI-36TL-480-V2 & PVI 50/60TL-480
CONVERSION TECHNOLOGY	3 – Level conversion technology with space-vector PWM	
HIGH EFFICIENCY	Max 97%, CEC 96.5%	Max 98.8%, CEC 98.5%
GRID ADAPTABILITY	Supports multiple grid trip set points Pre-set grid set points: IEEE 1547, CA Rule 21, HECO, ISO-NE Adjustable reactive power Adjustable power factor (PF) ±0.8 Remote power curtailment	Supports multiple grid trip set points Pre-set grid set points: IEEE 1547, CA Rule 21, HECO, ISO-NE Adjustable reactive power Adjustable power factor (PF) ±0.8 Remote power curtailment <i>(For 50&60TL only) Dual Rated</i> Selectable apparent power overhead that allows full power output down to a power factor of 0.91
CONNECTIVITY	Modbus RTU, SunSpec Modbus and HTTPS/XML Ethernet Network Card (optional) allows for remote firmware upgrades and advanced controls of the inverter	
USER INTERFACE (UI)	LCD screen with touchpad controls	
LONG SERVICE LIFE	Designed with thin-film capacitors to extend the inverter service life	
MULTICHANNEL MPPT CONFIGURATION	3 MPPT zones 2 strings per zone	3 MPPT zones 5 strings per zone
PROTECTIVE ENCLOSURE	NEMA Type 4X Corrosion resistant aluminum Rated for indoor and outdoor use	
RAPID SHUTDOWN READY	APsmart PLC transmitter, power supply, and CT's installed in wiring box	Optional: APsmart PLC transmitter, power supply, and CT's installed in wiring box
EASY INTEGRATION	Integrated AC and DC switches 6 positive-fused string input positions *positive-fused per 2017 National Electric Code allowance	Integrated AC and DC switches Standard wiring box: 15 positive & negative-fused string input positions RSD wiring boxes: 15 positive-fused string input positions
BIFACIAL MODULES	Compatible with Bifacial Modules. Please see Yaskawa Solectria Solar Bifacial Module Application Note.	

3.3 Inverter Protections

OUTPUT MONITORING	AC output voltage and frequency monitoring
ANTI-ISLANDING	Bidirectional frequency perturbation based on Sandia Frequency Shift Detection
OVER VOLTAGE PROTECTION	Integrated input and output over-voltage protection
OVER CURRENT PROTECTION	Input and output over-current protection
GROUND MONITORING	DC input insulation to ground monitoring
SHORT CIRCUIT PROTECTION	AC and DC short circuit protection
ARC FAULT	DC series arc fault detection and circuit interruption
LEAKAGE CURRENT MONITORING	Leakage current to ground monitoring
TEMPERATURE MONITORING	Internal enclosure temperature monitoring IGBT power module temperature monitoring
KVA OVERHEAD	kVA overhead to produce rated Active Power at 0.91 power factor
LOAD REJECTION OVER VOLTAGE (LROV) PROTECTION	Protection from LROV events
NO NEUTRAL REQUIRED	No neutral connection required
RAPID SHUTDOWN	PVRSS certified rapid shutdown compliant to 2017 NEC
CONTINUOUSLY MONITORED VARIABLES	DC input insulation resistance with respect to ground Third harmonic injection AC output voltage and frequency Leakage current to ground Internal enclosure temperature IGBT power module temperature

3.4 Smart Inverter Functions (default state)

PARAMETER	IEEE1547-2018	RULE 21	ISO-NE
ANTI-ISLANDING	Enabled	Enabled	Enabled
LOW/HIGH VOLTAGE RIDE-THROUGH	Enabled	Enabled	Enabled
LOW/HIGH FREQUENCY RIDE-THROUGH	Enabled	Enabled	Enabled
DYNAMIC VOLT/VAR	Enabled	Enabled	Not Activated
RAMP RATES	Enabled	Enabled	Enabled
FIXED POWER FACTOR	Enabled	Not Activated	Not Activated
SOFT START RECONNECTION	Enabled	Enabled	Enabled
FREQUENCY-WATT	Not Activated	Enabled	Not Activated
VOLT-WATT	Enabled	Enabled	Not Activated

**ACTIVE POWER
CURTAILMENT**

Not Activated

Not Activated

3.5 Inverter Diagrams

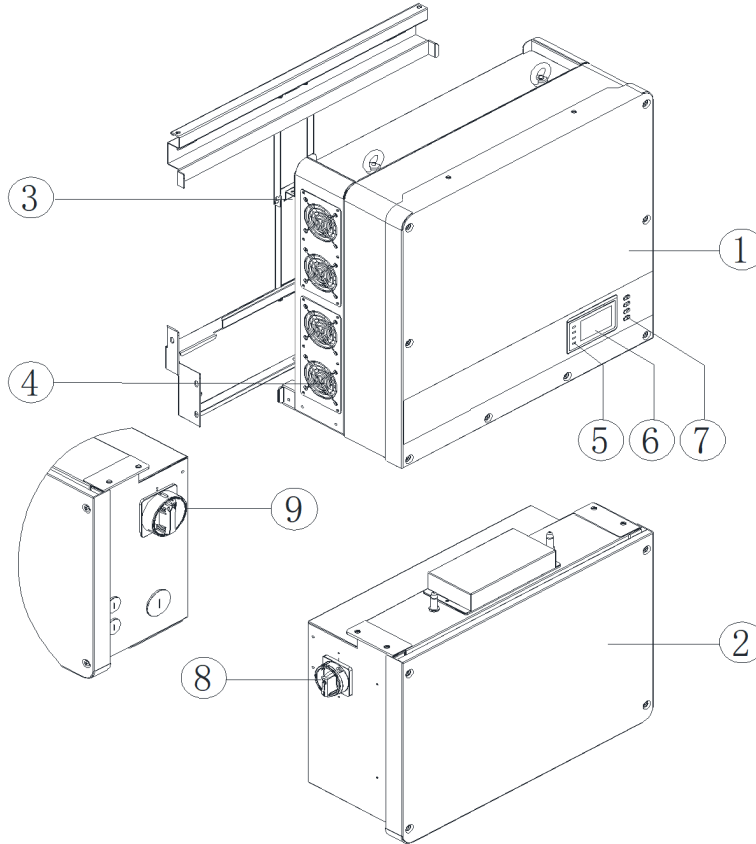

Figure 3-2 SOLECTRIA PVI 25TL-208, PVI-36TL-480-V2, PVI 50TL-480, and PVI 60TL-480 Inverter

Main Items of the Inverter:

- ① Main inverter enclosure
- ② Inverter wiring box
- ③ Inverter mounting bracket
- ④ Cooling fans
- ⑤ LED indicator lights
- ⑥ User LCD display
- ⑦ User Key buttons
- ⑧ DC switch: DC power on/off
- ⑨ AC switch: AC power on/off

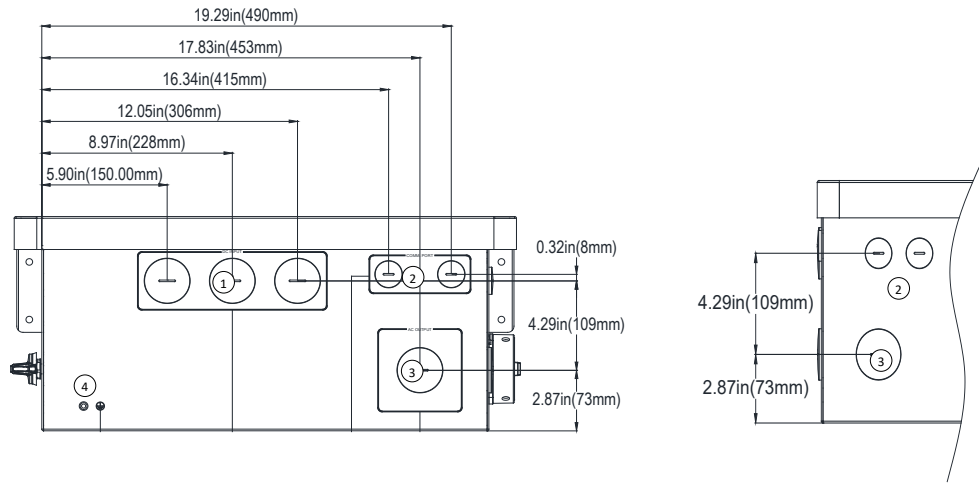

Figure 2-4 Wire-box Conduit Knockout Locations

- ① Knockouts for DC input, (1) 1-1/2 inch Trade Size
- ② Knockout for communication, (4) 3/4 inch Trade Size
- ③ Knockouts for AC output, (2) 1-1/2 inch Trade Size
- ④ External ground connection point (M6)

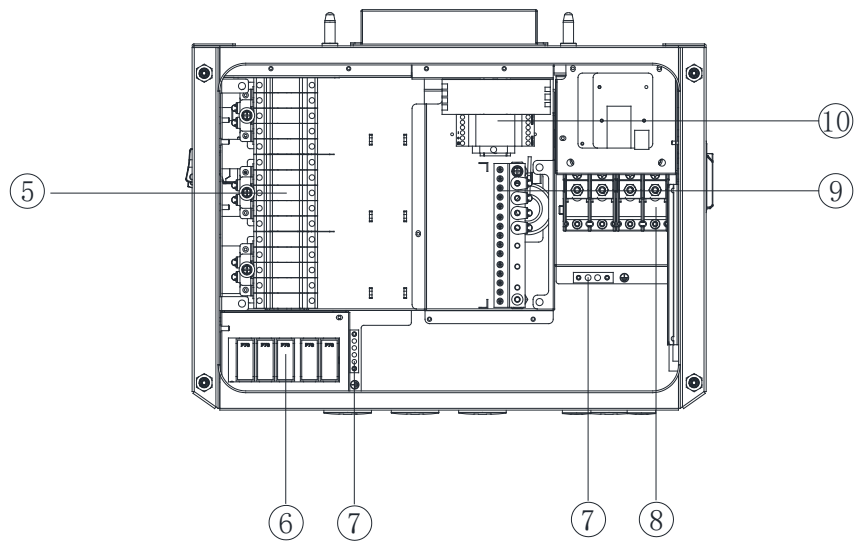

Figure 2-5 Wire-box Internal Connection Points (PVI 50/60TL-480) See Section 4.3.2 for all configurations.

- ⑤ DC Input fuse holder/terminal

- ⑥ DC SPD (Surge Protective Device)
- ⑦ Internal ground terminal
- ⑧ AC output terminal block
- ⑨ Negative DC input busbar
- ⑩ Rapid Shutdown transmitter

3.6 Schematic Diagram and Circuit Design

The basic electrical schematic diagram of the PVI-36TL-480-V2, PVI 50TL-480 and PVI 60TL-480 inverters with a standard wire box is shown in Figure 3-3; the schematic diagram of the same inverters with the MLPE (rapid shutdown transmitter integrated) wire box is show in Figure 3-4. The diagram for the PVI 25TL-208 is shown in Figure 3-5.

The input from PV source circuits passes through surge protection circuitry, DC EMI wave filters, and independent DC-DC boost circuitry to achieve maximum-power-point tracking and boost the voltages to a common DC bus. The inverter uses line voltage and frequency measurements to synchronize to the grid and converts the available PV power to AC power by injecting balanced 3-phase AC current into the electric utility grid. Any high frequency AC component is removed by passing through a two-stage relay and EMI wave filter to produce high quality AC power.

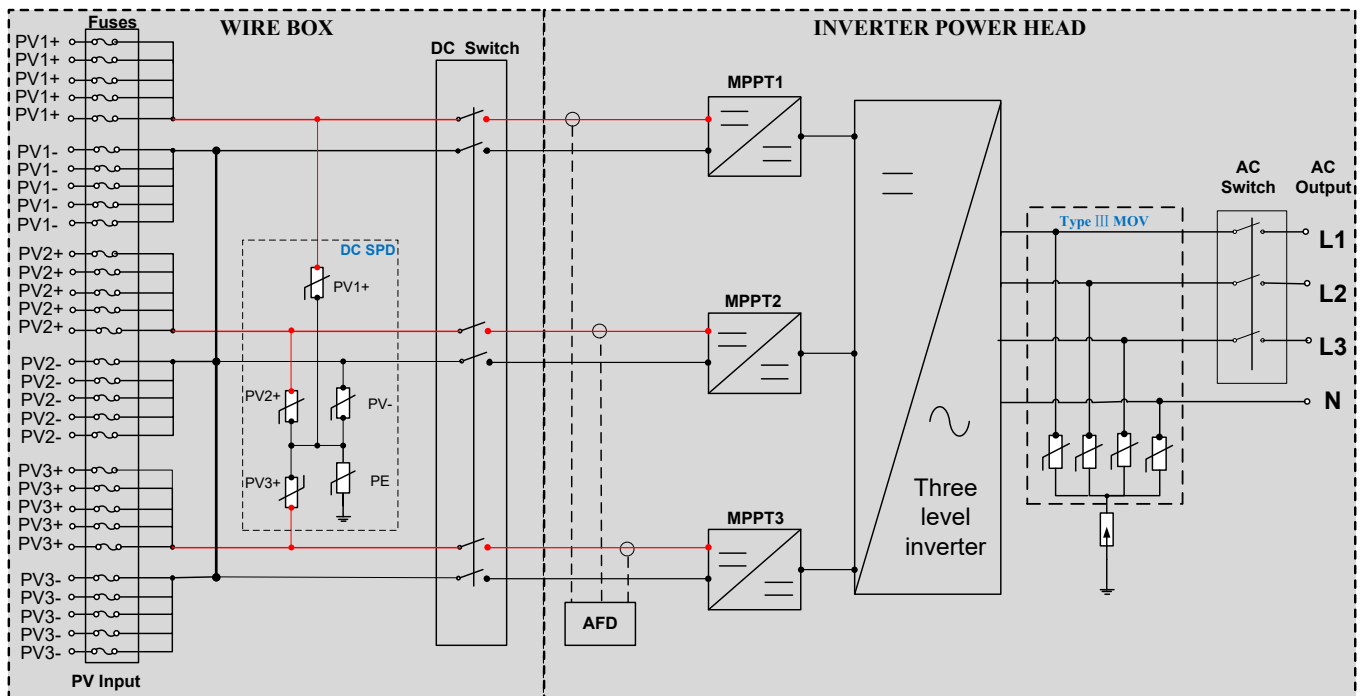

Figure 3-3 PVI-36TL-480-V2 & PVI 50/60TL-480 Inverter Schematic, Standard Wire Box

The Rapid Shutdown wire box has been designed specifically for NEC 2017+ Rapid Shutdown applications. This wire box includes a powerline communications transmitter, powered by AC at the inverter output. This transmitter sends a “stay alive” signal to AP Smart receivers at the array. When the inverter senses the loss of AC

voltage by way of opening the PV system disconnect switch, inverter circuit breaker or under loss of grid events, the transmitter stops transmitting the “stay alive” signal sending the MLPE devices into rapid shutdown. This rapid shutdown system has been UL PVRSS listed and compatibility tested and is a certified platform to conform to 690.12 of the 2017 National Electric Code. Please refer to the RSD Compatibility and Listing Matrix Application Note for the most up to date information on models that have been tested and listed with Solectria inverters.

The wire boxes that have module-level rapid shutdown transmitters integrated into them do not have negative fusing. This is in conformance with NEC 2017 690.9(C).

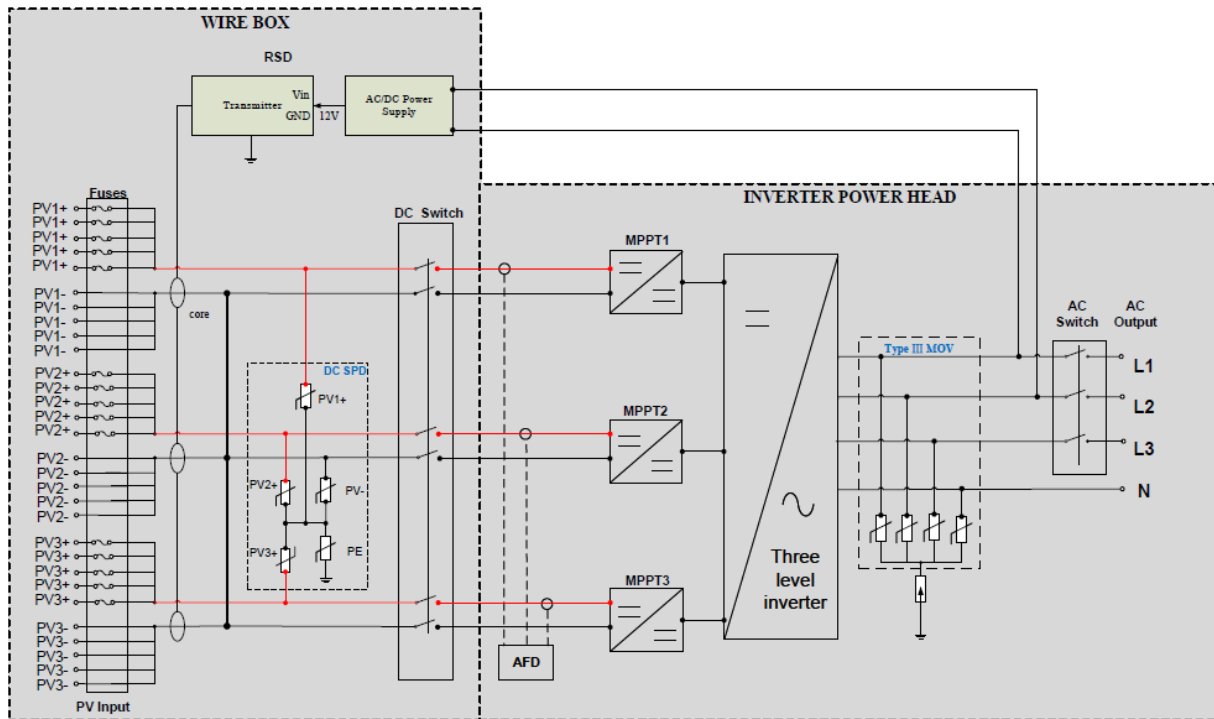

Figure 3-4 PVI 50/60TL-480 Inverter Schematic, Module-Level Rapid Shutdown Wire Box

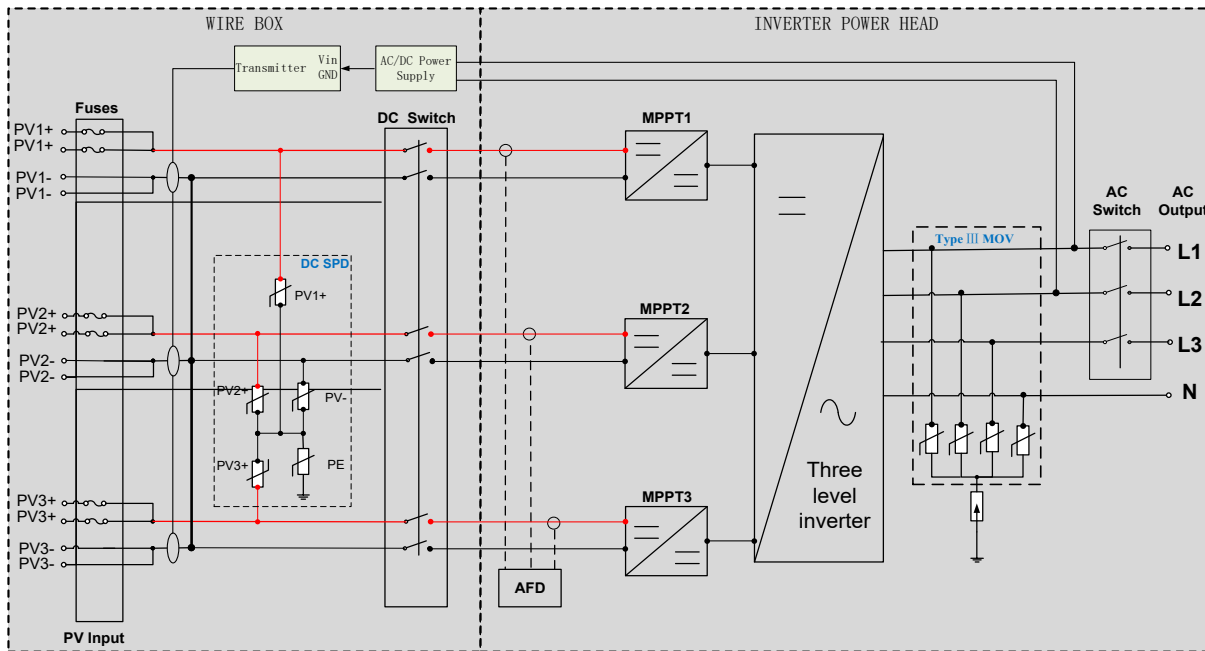

Figure 3-5 PVI 25TL-208 Inverter Schematic, Module-Level Rapid Shutdown Wire Box

3.7 Anti-islanding Detection

The SOLECTRIA PVI 25TL-208, PVI-36TL-480-V2, PVI 50TL-480, and PVI 60TL-480 3-Phase String Inverters include unintentional islanding detection as required by UL 1741/IEEE 1547. The inverter will continuously make bi-directional perturbations to the frequency of the output current by injecting a small amount of reactive power to detect a possible islanding condition. If the grid is stable, these small perturbations will have negligible effects on the system voltage frequency. However, in an islanded condition the changes in reactive power will force the frequency of the system voltage to deviate significantly, which will trigger the inverter to cease operation and disconnect from the grid.

3.8 DC Ground Fault Protection

The inverters include residual current detection GFCI as part of the DC ground fault detection method required by UL 1741. If there is a ground fault in the PV array, the ground fault detection circuitry will detect leakage current, trigger an alarm, and the inverter will cease operation. See section 7.1.2.8 for further information regarding GFCI Static and Dynamic trip thresholds and operation.

3.9 Surge Suppression

Table 3-1 Standard Waveform Peak Values

STANDARD WAVEFORM PEAK VALUES		
SURGE CATEGORY	Ring Wave	Combination Wave
B	6kV/0.5kA	6kV/3kA

- "Standard 1.2/50 μ s - 8/20 μ s Combination Wave"
- "Standard 0.5 μ s - 100 kHz Ring Wave"

3.10 DC Arc-fault Protection

The inverters include DC Arc-fault detection compliant with UL 1699B-2018. The inverter will detect electrical noise that is indicative of a DC series arc. Upon detection of an arc-fault, the inverter will cease operation.

3.11 Module-Level Rapid Shutdown

The RSD versions of the inverter wire boxes include a SunSpec powerline communication transmitter for use with certain APsmart receivers. Please order the corresponding wire box to the receivers used on site as the transmitters are different. These inverters are PVRSS certified with APsmart, NEP and Tigo devices to perform module-level rapid shutdown in compliance with 2017 NEC 690.12.

When the inverter is connected to AC power, the PLC transmitter receives power via an integrated power supply. Once the transmitter is powered it will send a “keep alive” signal to the rapid shutdown receivers at the array. Once the inverter senses the grid is missing, whether by the opening of the PV system disconnect, inverter circuit breaker or by a loss of grid, the transmitter will cease sending this signal. When the rapid shutdown receivers at the PV modules do not receive the “keep alive” signal, they enter shutdown mode reducing the module output to at most 0.6V. The transmitter is capable of signaling these devices up to 500’ (1000’ entire circuit length; to the module and back).

Please refer to the RSD Compatibility and Listing Matrix Application Note for the most up to date information on models that have been tested and listed with Solectria inverters.

Every module-level rapid shutdown system has specific installation instructions for its receivers. These installation instructions, found on the original manufacturer’s websites, must be followed for a successful and safe installation.

3.12 Communication Overview

The SOLECTRIA PVI 25TL-208, PVI-36TL-480-V2, PVI 50TL-480, and PVI 60TL-480 inverters support industry standard Modbus RS-485 communications for monitoring purposes. In addition to SolrenView and/or third party monitoring, these inverters are also able to send data to an online portal which is used for remote diagnostic purposes. This capability can provide remote firmware upgrades and remote troubleshooting and is an accessory that is available for individual purchase. This function is performed by the Ethernet Network Card (version ENC-G4 and above).

Each Ethernet Network Card can handle up to 32 inverters. If a site has more than 32 inverters, additional Ethernet Network Cards will be needed. When a third party monitoring system is used, the DAS can be connected to the Ethernet Network Card, and the Ethernet Network Card is then connected to the inverters or if no Ethernet Network Card is desired, the DAS can be connected directly to the Communications Card.

Each inverter has a Communication Board installed in the wiring box which is used to daisy chain the inverters using RS-485 for communication purposes. The Ethernet Network Card should be mounted on the communications card of the first or last inverter in the daisy chain.

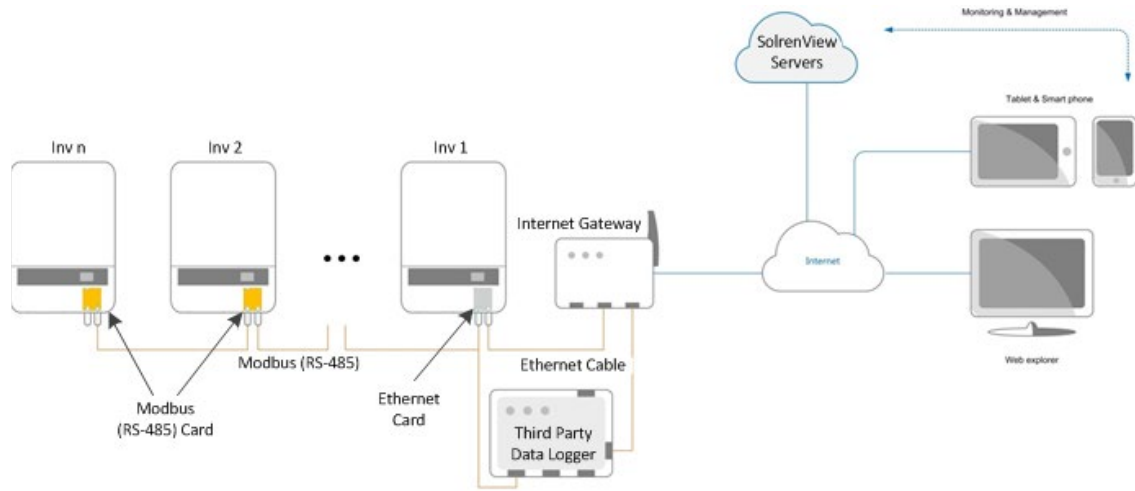

Figure 3-6 Communications Overview

3.13 Labels

The SOLECTRIA PVI 25TL-208, PVI-36TL-480-V2, PVI 50TL-480, AND PVI 60TL-480 has labels on the Power Head. Do not deface these labels as they contain important information required for warranty service. The labels on the Power Head show the inverter specifications and FCC compliance. See Figure 3-7.

<p>YASKAWA SOLECTRIA SOLAR Grid-Tied PV Inverter(Grid Support Non-Isolated)</p> <p>Model No.: PVI25TL-208-R Nominal input power: 26kW Number of inputs: 3 x 2 Max. input voltage: 1000Vdc Operating input voltage range: 200—950Vdc MPPT voltage range: 480—850Vdc Max. input current: 3 x Each 18A Max. input short circuit current: 3 x Each 45A Nominal AC power: 25kVA Nominal AC voltage: 208Vac/183—228Vac 3Ø Nominal power frequency: 60Hz/57—63Hz Max. AC current: 69.5A AC current THD: <3% Power factor: >0.99(adj.±0.8) Max. Efficiency: 97% CEC Efficiency: 96.5% Operating temperature range: -30°C—+60°C (>45°C derating) Ingress protection: TYPE 4X Made in xxxxx</p> <p>FC This device complies with part 15 of the FCC Rules RoHS SP US Serial Number UL 1741 (including SA) Cert.to CSA Std.C22.2 No.107.1</p>	<p>YASKAWA SOLECTRIA SOLAR *This inverter is factory set at 36kVA DEFAULT.</p> <p>Product Series: PVI-36TL-480-V2 Max. input power: 61.2kWstc Number of inputs: 3 x 5 Max. input voltage: 1000Vdc Operating input voltage range: 200—950Vdc MPPT voltage range: 400—850Vdc Max. input current: 31A per MPPT (3 x) 68A per MPPT (3 x) Max. input short circuit current: 39kVA Max. Active power: 36kVA Max. Apparent power: 480Vac/422—528Vac: 3Ø Nominal AC voltage: 60Hz/59.5—60.5Hz Nominal AC current: 43.5A Max. AC current: 43.5A AC current THD: <3% Power factor: >0.99(adj.±0.8) Max. efficiency: 97.4% CEC efficiency: 98.8% Operating temperature range: -30°C—+60°C (>45°C derating) TYPE 4X Ingress protection: TYPE 4X Made in xxxxx</p> <p>FC This device complies with part 15 of the FCC Rules RoHS SP US Serial Number UL 1741 (including SA/SS) Cert.to CSA Std.C22.2 No.107.1</p>	<p>YASKAWA SOLECTRIA SOLAR *This inverter is factory set at 50kVA DEFAULT. Contact YASKAWA to enable 55kVA setting.</p> <p>Product Series: PVI50TL-480 Max. input power: 75kWstc Number of inputs: 3 x 5 Max. input voltage: 1000Vdc Operating input voltage range: 200—950Vdc MPPT voltage range: 480—850Vdc Max. input current: 38A per MPPT (3 x) 68A per MPPT (3 x) Max. input short circuit current: 50kVA Max. Active power @50kVA & @55kVA: 50kW Max. Apparent power @50kVA / @55kVA: 50kVA / 55kVA Nominal AC voltage: 480Vac/422—528Vac 3Ø Nominal power frequency: 60Hz/59.5—60.5Hz Nominal AC current @50kVA/@55kVA: 60.2A/66.2A Max. AC current @50kVA/@55kVA: 60.2A/66.2A AC current THD: <3% Power factor: >0.99(adj.±0.8) Max. efficiency: 98.5% CEC efficiency: 98.8% Operating temperature range: -30°C—+60°C (>45°C derating) TYPE 4X Ingress protection: TYPE 4X Made in xxxxx</p> <p>FC This device complies with part 15 of the FCC Rules RoHS SP US Serial Number UL 1741 (including SA) Cert.to CSA Std.C22.2 No.107.1</p>	<p>YASKAWA SOLECTRIA SOLAR *This inverter is factory set at 60kVA DEFAULT. Contact YASKAWA to enable 66kVA setting.</p> <p>Product Series: PVI60TL-480 Max. input power: 90kWstc Number of inputs: 3 x 5 Max. input voltage: 1000Vdc Operating input voltage range: 200—950Vdc MPPT voltage range: 540—850Vdc Max. input current: 38A per MPPT (3 x) 68A per MPPT (3 x) Max. input short circuit current: 60kVA Max. Active power @60kVA & @66kVA: 60kW Max. Apparent power @60kVA / @66kVA: 60kVA / 66kVA Nominal AC voltage: 480Vac/422—528Vac 3Ø Nominal power frequency: 60Hz/59.5—60.5Hz Nominal AC current @60kVA/@66kVA: 72.2A/72.2A Max. AC current @60kVA/@66kVA: 72.2A/72.4A AC current THD: <3% Power factor: >0.99(adj.±0.8) Max. efficiency: 98.8% CEC efficiency: 98.5% Operating temperature range: -30°C—+60°C (>45°C derating) TYPE 4X Ingress protection: TYPE 4X Made in xxxxx</p> <p>FC This device complies with part 15 of the FCC Rules RoHS SP US Serial Number UL 1741 (including SA) Cert.to CSA Std.C22.2 No.107.1</p>
--	---	--	--

Figure 3-7 Example Power Head Labels

3.14 Unpacking

The SOLECTRIA PVI 25TL-208, PVI-36TL-480-V2, PVI 50TL-480, and PVI 60TL-480 inverters ship in two separate packages, consisting of A) the main inverter enclosure and B) the wire box, mounting bracket, user manual, and accessory kit. Prior to installation, be sure to store the packaged inverter(s) out of the elements. The inverter enclosures are not NEMA Type 4X rated until fully installed. Storage temperatures are -40°F to +158°F (-40°C to +70°C). Open the boxes carefully to avoid damaging the contents.

NOTICE!

Store Packaged Inverter Properly: Never expose packaged inverters to rain, water, snow, or other elements that may damage the electronics. The Power Head and Wiring Box are not NEMA Type 4X rated until fully installed. Failure to store the inverters properly will result in damage that is not covered under warranty.

INFO ✓

Do Not Discard Packaging Before Removing all Contents: There are multiple components in each box. Check packaging thoroughly before discarding.

4. Installation

This chapter describes the planning and installation procedures for the SOLECTRIA PVI 25TL-208, PVI-36TL-480-V2, PVI 50TL-480, and PVI 60TL-480 3-phase string inverters. Please read carefully and install the products following the step-by-step instructions.

The inverter and other main items are shipped in two separate packages, consisting of A) the main inverter enclosure and B) the wirebox, mounting bracket, user manual, and accessory kit. Before installation, please check that the following items are included in the packages:

Table 4-1 Main Items

NO.	ITEM	QTY	NOTE	BOX
(1)	Main inverter section	1	It is possible to receive and install the wiring box first and the inverter later.	A
(2)	Wiring box (Standard or RSD version)	1	There are two types of wiring box. Standard wiring box: Integrated DC fuses with every string. RSD wiring box: With RSD function, no negative fuses.	B
(3)	Mounting bracket	1	Upon which inverter is hung and mounted onto a wall	B
(4)	User manual	1	Installation and operation manual	B

(5)	Accessory kit	1	Kit contains all necessary hardware and accessories for installation	B
-----	---------------	---	--	---

Table 4-2 Accessory Kit

NO.	ITEM	QTY	NOTE
(1)	M6 X18mm Phillips screw	12	4 for securing the wiring box to the main enclosure; 6 for securing the inverter to the mounting bracket; 1 for the External Ground connection, 1 spare
(2)	5 pin PCB connector plug	1	For the RS485 communication (Input)
(3)	3 pin PCB connector plug	1	For the RS485 communication (Output)
(4)	M8 Nut	4	For AC terminal block
(5)	M8 Flat washer	4	For AC terminal block
(6)	M8 Spring washer	4	For AC terminal block
(7)	Phillips screw	1	Spare (for wiring box cover)

INFO ✓

The items above in Table 4-2 Accessory Kit are for the typical installation configuration. The accessories provided may vary if optional parts are purchased.

WARNING

Read These Instructions: Failure to follow these installation instructions may result in personal injury or death. Read this section in its entirety before attempting to install a SOLECTRIA PVI 25TL-208, PVI-36TL-480-V2, PVI 50TL-480, or PVI 60TL-480 inverter.

NOTICE!

Improper Installation Will Void Warranty: This section includes important information regarding the proper installation environment and mechanical and electrical requirements. Failure to follow these instructions will void the warranty.

NOTICE!

Maintain NEMA 4X Rating: Water ingress could result in unsafe conditions. Please take note of the following recommendations in order to maintain the NEMA rating and prevent water from entering into the system.

- Do not add weep holes or any other holes to the inverter or wire box. Doing so will void the warranty.
- For earlier wire box models with a gland plate – the conduit connections must be strain relieved to ensure the plate to gasket interface is water-tight. Water-tight metal flex conduit is one method.
- All conduit entries must be metallic.
- All conduits must be sealed to prevent moisture ingress.
 - Sealing conduit entries at the PV array will provide additional protection. Firestop putty or electrically rated conduit foam is recommended.

NOTICE!

Allowable Ambient Temperature Ranges:

- Storage Temperatures: -40°C to 70°C, Inverter not installed and in storage (in packaging or unpackaged).
- Normal Operating Temperatures: -30°C to 60°C, Inverter installed, connected to electric utility grid, and operating during daylight hours.
- Connected but Off Temperatures: Max temp 70°C with no lower limit on temperature, Inverter installed, connected to electric utility grid but non-operating (daylight or nighttime hours).

The bulkhead connector cover does not provide a water-tight seal. If the power head is not to be installed immediately on the wire box, the installer will need to provide a water-tight seal over the bulkhead connector until inverter power head is installed.

PRE-INSTALLATION CHECKLIST

- Check that the inverter environmental specifications (protection degree, operating temperature range, humidity and altitude, etc.) meet the requirements of the specific project location.
- Make sure that the electric utility grid voltage is within range for the grid standard chosen.
- Ensure that the local electric utility grid authority has granted permission to connect to the grid.
- Installation personnel must be qualified electricians or those who have received professional training.
- Wear and use proper personal protective equipment (PPE) during installation.
- Sufficient space according to Figure 4-3 must be provided to allow the inverter cooling system to operate effectively.
- Install the inverter away from flammable and/or combustible substances.
- Avoid installing the inverter in locations that exceed the temperature limits specified for the inverter to prevent undesirable power loss.

NOTICE!

Outdoor Installations that are Left for Extended Periods of Time without Power: Yaskawa Solectria Solar advises against leaving inverters mounted outdoors for an extended period of time (more than 90 days) or exposing the inverters to cycles of freezing temperatures without both DC and AC power connected to the inverters.

The inverter enclosures are tested and rated NEMA 4X. However, there exists the possibility of water condensation inside the inverter enclosure when it is left exposed to an outdoor environment without power for an extended period of time. Humidity can enter the power head through a small opening between itself and the wiring box. When the inverter is exposed to temperature swings, especially in cold weather, moisture inside the inverter power head could condense over the aluminum heatsink area where inverter semiconductors are mounted. Water droplets on the heatsink may cause a short circuit on live semiconductor devices. When a PV source is applied to the inverter, this PV power source could cause the inverter to fail and result in a short circuit across the PV array.

If the inverter is mounted outdoors without operating power for an extended period of time, Yaskawa Solectria Solar recommends that the inverter power head be inspected for water condensation before any DC or AC power is applied to the inverter. Without inspection, customers run the risk of having electronic circuit damage when power is applied to the inverter during startup.

WATER INGRESS WILL VOID WARRANTY: It is the responsibility of the installer to maintain a dry, moisture-free inverter enclosure; water ingress is not covered under warranty.

This Installation Section is broken into three sub-sections: Mechanical Installation, Electrical Installation and Communications Installation.

Each subsection begins with general requirements and guidelines which must be considered when designing a system and planning the installation. Each sub-section is concluded with detailed systematic instructions to install the SOLECTRIA PVI 25TL-208, PVI-36TL-480-V2, PVI 50TL-480, or PVI 60TL-480 inverter.

4.1 Installation Sequence Overview

CAUTION

Lifting Heavy Object Hazard: Proper lifting techniques must be used in order to avoid injuries. The Power Head weighs 123.5 pounds (56 kg).

1. Install the Mounting Bracket.
2. Install the Power Head.
3. Remove bulkhead connector cover from top of Wiring Box.
4. Install the Wiring Box.
5. Connect the Power Head and Wiring Box together.
6. Confirm that the site AC breaker is set to OFF.

7. Remove the cover of the Wiring Box.
8. Ensure correct polarity of the PV Strings before terminating the DC source circuits within the Wiring Box.
9. Land the input PV circuit conductors by connecting to the DC fuse holders in the Wiring Box.
10. Land the AC conductors from the grid to the AC terminal block in the Wiring Box, ensuring a positive phase rotation.
11. Land the communication conductors.
12. Seal all the conduit entrances with electrically rated conduit foam to restrict air flow to maintain enclosure's NEMA Type 4X rating.
13. Replace the plastic shields and the cover of the Wiring Box.

4.2 Mechanical Installation

4.2.1 Inverter Environment

The SOLECTRIA PVI 25TL-208, PVI-36TL-480-V2, PVI 50TL-480, AND PVI 60TL-480 inverters are equipped with a NEMA Type 4X rated, Polyester Powder-Coated Aluminum enclosure suitable for outdoor installation in many different climates. Select the mounting location appropriately taking into consideration snow, wind, rain, direct sun, pests, vegetation growth, and any other local environmental conditions. To increase its life span, it is recommended that the inverter be installed out of direct sunlight; for example, under a shade structure, on a north facing building wall, or on north facing racking. Never install inverters in areas that are prone to flooding, standing water, prolonged snow coverage, or near explosive or flammable materials.

WARNING

Explosion or Fire Hazard: Electrical devices can cause fires. Never install in areas prone to explosive gasses, liquids, or in close proximity to flammable materials.

NOTICE!

Maintain NEMA Type 4X Rating: It is the responsibility of the installer to maintain the NEMA Type 4X rating of the enclosure. Failure to maintain the NEMA Type 4X rating will void the warranty.

NOTICE!

Improper Installation Will Void Warranty: Never install the inverter in areas that are prone to flooding, standing water, or prolonged snow coverage. It is important to ensure the cooling fans and exhausts remain clear from obstructions at all times.

INFO ✓

Temperature Derating: The SOLECTRIA PVI 25TL-208, PVI-36TL-480-V2, PVI 50TL-480, and PVI 60TL-480 inverters are rated for a wide range of operating temperatures. When installed in environments that may experience

ambient temperatures near or above the derating temperature of 113°F (45°C), it is best to keep the inverter out of direct sunlight to minimize temperature de-rating and extend product life.

4.2.2 Inverter Dimensions

The dimensions of the SOLECTRIA PVI 25TL-208, PVI-36TL-480-V2, PVI 50TL-480, AND PVI 60TL-480 inverters are shown in Figure 4-1.

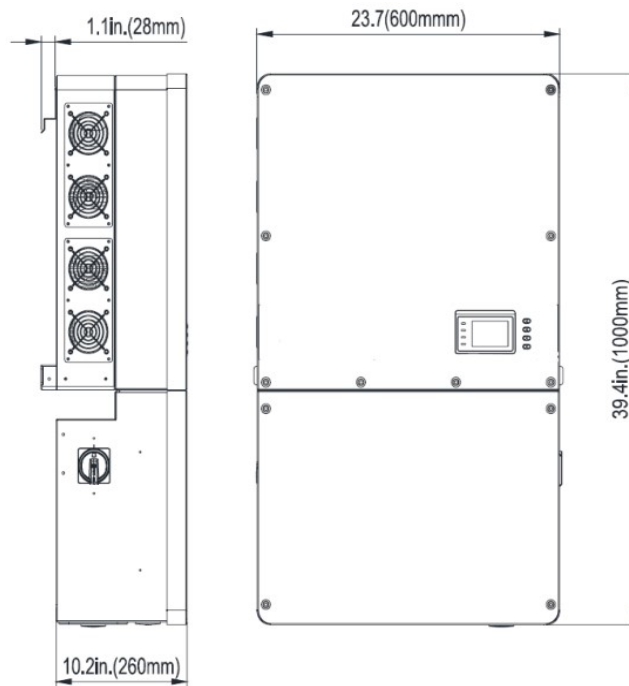

Figure 4-1 Inverter Dimensions

4.2.3 Inverter Mounting Angle and Orientation

The SOLECTRIA PVI 25TL-208, PVI-36TL-480-V2, PVI 50TL-480, AND PVI 60TL-480 inverters are designed to accommodate mounting angles between vertical and 75° from vertical. If tilted at 15° from vertical (75° from horizontal), or shallower (closer to horizontal), in an outdoor environment, the Shade Cover accessory is required. See Section 10.2.1 for more details. When possible, install the inverter vertically facing north to minimize damage caused by sunlight exposure and to improve ventilation.

1. The Power Head must be installed above the Wiring Box. Never install the inverter upside down.
2. If the location permits, install the inverter mounted vertically.
3. If the inverter cannot be mounted vertically, it may be tilted backward at any angle from vertical to 15° from horizontal.
4. When tilted backward at $\leq 75^\circ$ from horizontal (15° from vertical) in an outdoor environment, the **MTLSR-070551** accessory is required to be installed. See Section 10.2.1 for more information.
5. Do not mount the inverter leaning forward.

6. The bottom edge of the Wiring Box must remain horizontal (perpendicular to a plumb line). No side-to-side tilting is permitted.

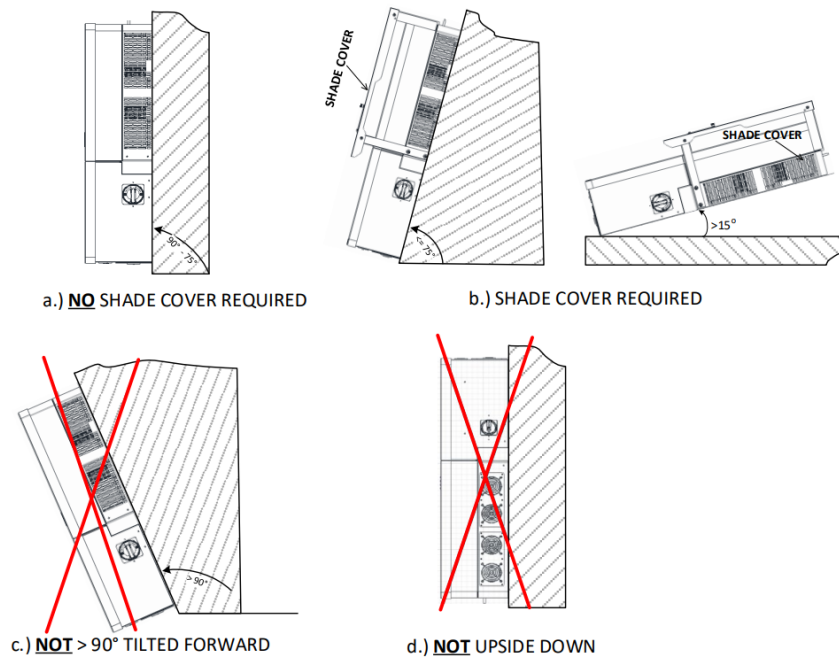

Figure 4-2 Inverter Mounting Options

4.2.4 Inverter Spacing

It is important to allow ample spacing for ventilation, wire management, and service. The minimum spacing requirements are shown in Figure 4-3. Always keep the clearance area free from debris, plants, and other obstructions.

NOTICE!

Improper Installation Will Void Warranty: The requirements defined in this section are the minimum allowable clearances. In areas that experience deep snows, heavy rain, excessive heat (greater than 45°C), or excessive vegetation growth, it may be necessary to increase spacing. It is the responsibility of the installer to ensure the clearance area remains free from debris, plants, and other obstructions at all times. The recommended spacing below the inverter can be modified according to installation requirements. Install the inverter higher than the flood line and/or typical snow build-up.

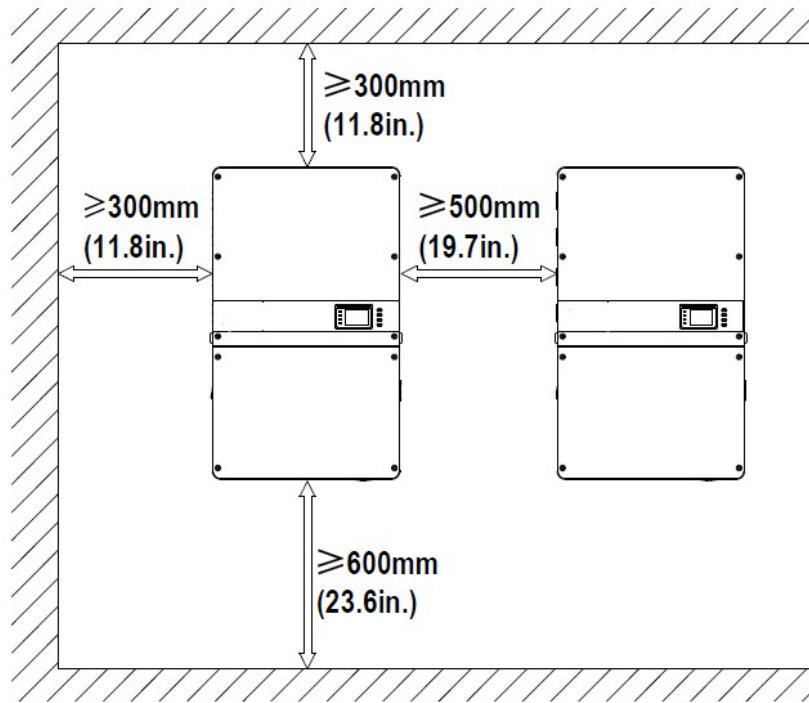

Figure 4-3 Inverter Minimum Spacing and Clearance Area

NOTICE!

The installation clearance between two inverters must be increased to 30 in. when the ambient temperature is higher than 45°C.

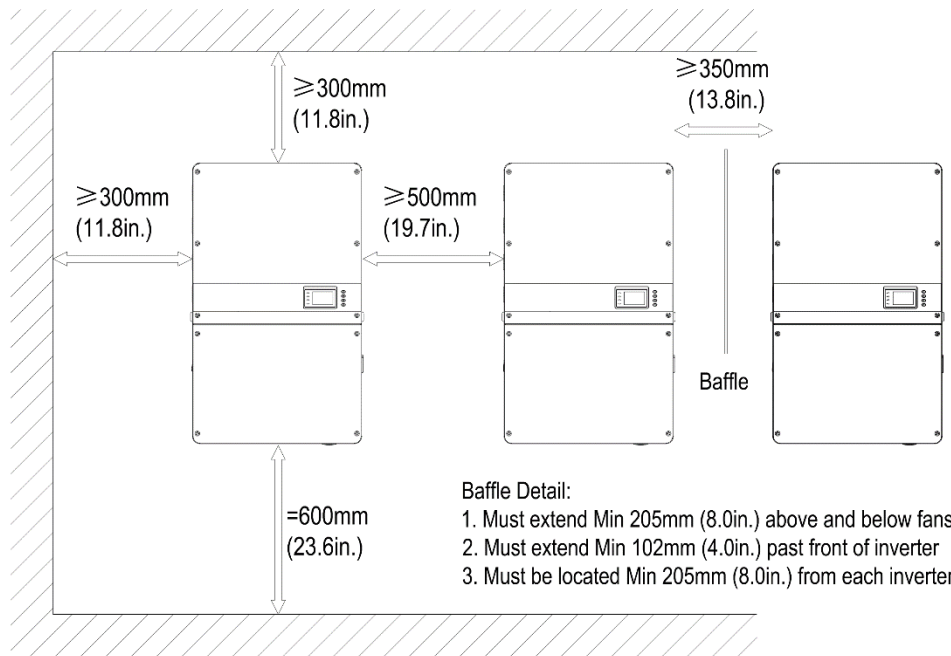

Figure 4-4 Inverter Wall Mounting Baffle Details

NOTICE!

Ensure that the air space around the inverter is well ventilated. The spacing between two adjacently wall mounted inverters may be reduced to $\geq 16\text{in}$ (350mm) provided a baffle is installed. Installing an aluminum or galvanized steel baffle (Not supplied by Yaskawa Solectria Solar) with the dimensions detailed above is intended to divert or deflect warm exhaust air from entering the adjacent inverter. Elevated ambient air temperature $\geq 45^\circ\text{C}$ will cause the inverter to enter a thermal derating mode and reduce its active power output.

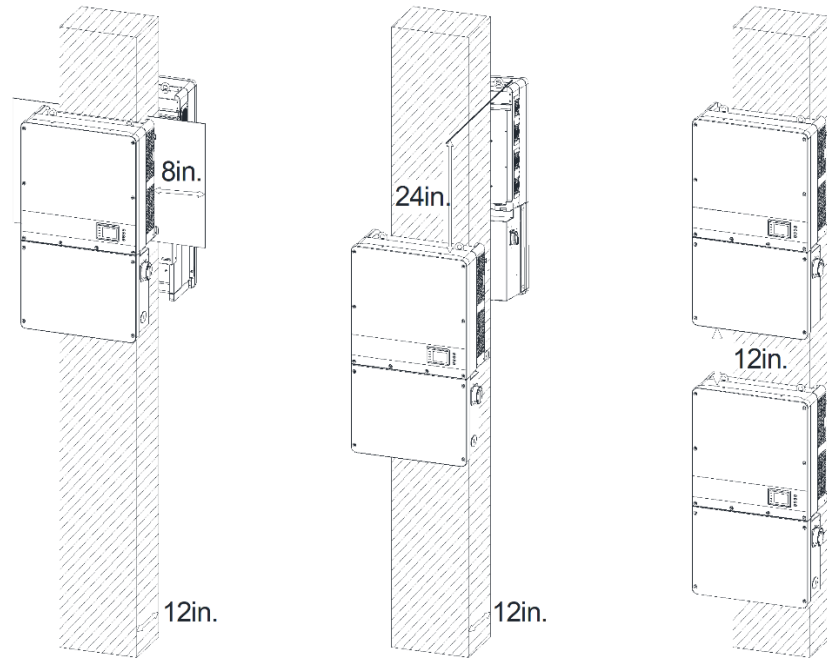

Figure 4-5 Inverter Pillar or Column Mounting Dimensions

INFO ✓

If the inverter is installed on a pillar or column (instead of solid wall), the space from the bottom of one inverter to the top of the inverter below may be as small as 11.8in (300mm).

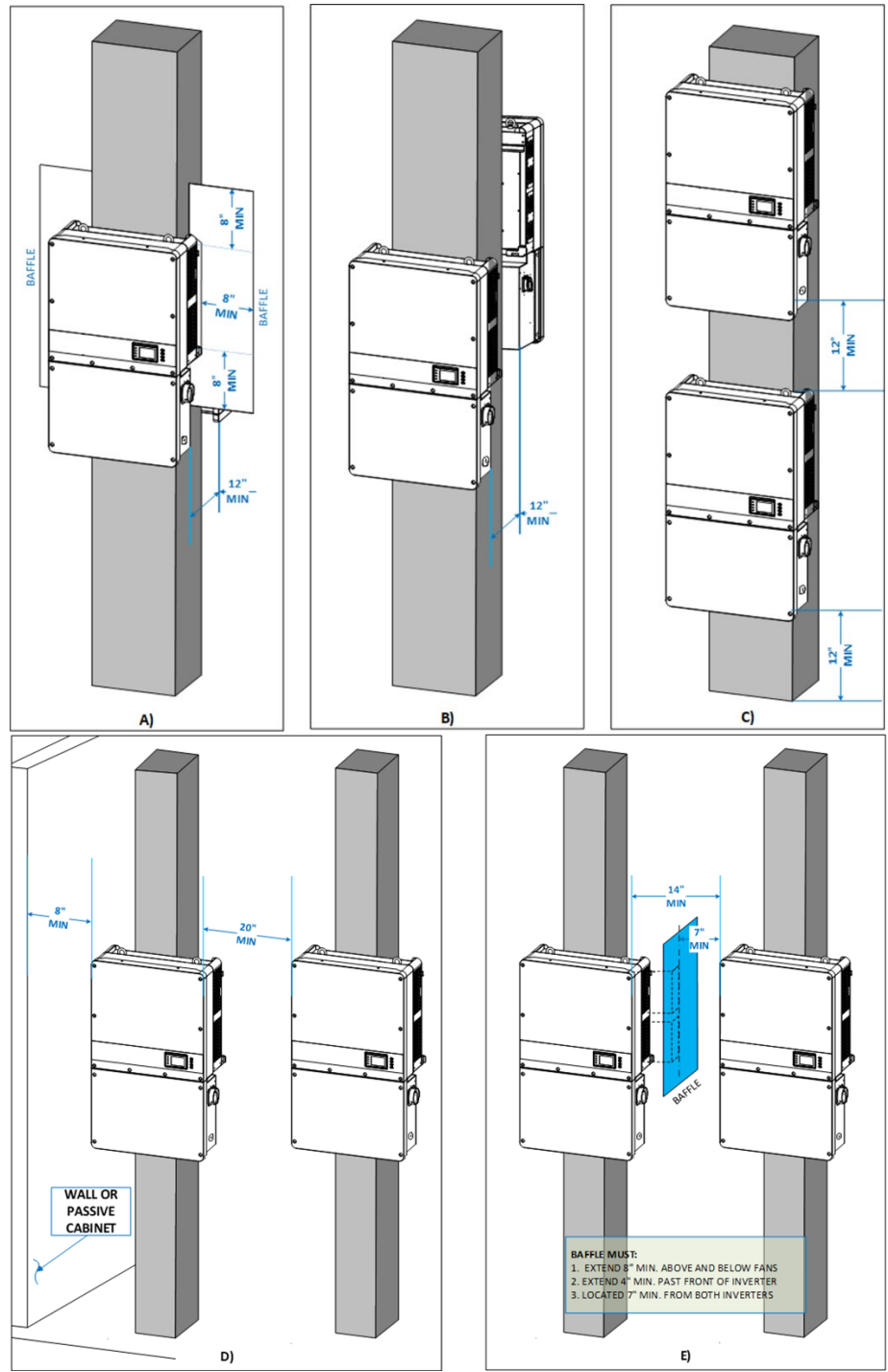

Figure 4-6 Inverter Pillar Mounting Specifications

4.2.5 Mounting

A mounting bracket, shown in Figure 4-9, is provided with each SOLECTRIA PVI 25TL-208, PVI-36TL-480-V2, PVI 50TL-480, and PVI 60TL-480 inverter. The mounting bracket must be securely attached to a structurally sound, flat surface. Acceptable surfaces include U-channel metal racking (such as Unistrut), concrete, and other non-flammable surfaces.

The total installed weight of the SOLECTRIA PVI 25TL-208, PVI-36TL-480-V2, PVI 50TL-480, and PVI 60TL-480 inverter with wiring box is 156.5 lbs (71 kg). It is the responsibility of the installer to perform a structural analysis of the intended mounting surface.

NOTICE!

Improper Installation Will Void Warranty

- Always use the provided mounting bracket secured to a structurally sound surface.
- Never modify the inverter Power Head or Wiring Box enclosure. Doing so will void the warranty

CAUTION

Improper Installation may result in Property Damage or Personal Injury

- Never install the inverter directly to drywall unless attached to a structural member.
- Installing the inverter without the mounting bracket may result in property damage or personal injury.

INFO ✓

Mounting Hardware is Not Included: The SOLECTRIA PVI 25TL-208, PVI-36TL-480-V2, PVI 50TL-480, AND PVI 60TL-480 inverters are not supplied with fasteners to attach the Mounting Bracket to the substrate. These must be purchased separately.

4.2.5.1 Mounting Inverter to Bracket

Locate and mark the 8 holes on the wall, PV racking structure, or weight bearing surface for attaching the inverter mounting bracket as shown in Figure 4-7.

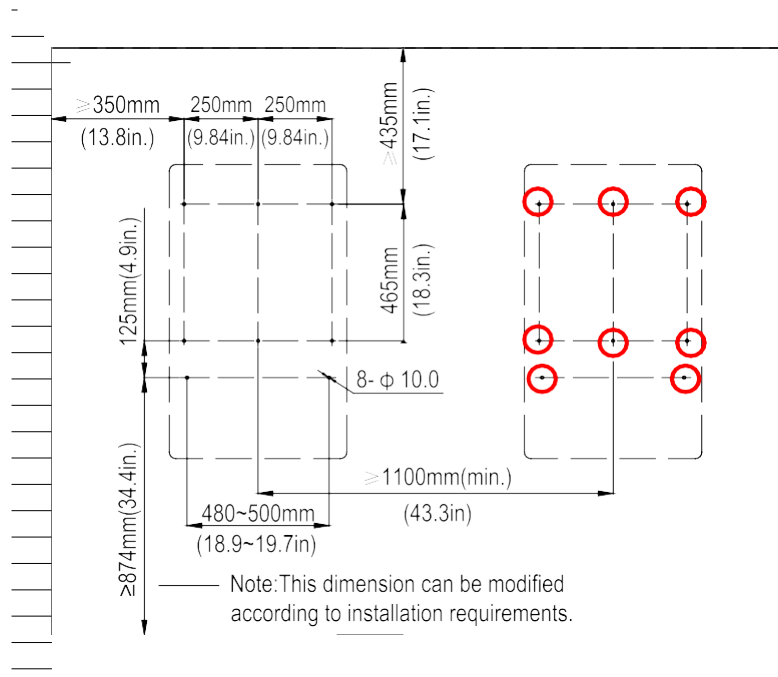

Figure 4-7 Mounting Bracket - Hole Locations

Referring to Figure 4-9, drill holes at the marked positions with a 10mm (0.4in.) drill and put the M8 expansion tubes, labeled as ①, into the holes; assemble and fasten the mounting brackets, labeled as ②, with the M8x25 assembling bolts, labeled as ③, supplied with the accessory kit. Tool: Electric drill (Φ 10mm/0.4in. head), 13mm wrench 240 in-lbs.

INFO ✓

Mounting the Bracket to PV Racking: the M8 nuts are not provided in the Accessory Kit. Tools Required: No. 13 wrench(es)

Concrete Wall Mount: Drill holes at the marked positions with a 0.4in. (10mm) masonry bit and insert M8 Expansion Anchors into the holes (expansion anchors not provided); Fasten the Mounting Bracket with the M8x25 Assembling Bolts supplied with the Accessory Kit. Figure 4-8 and Figure 4-9. Tools Required: Electric drill (Φ 10mm/0.4in. masonry bit), No. 13 wrench

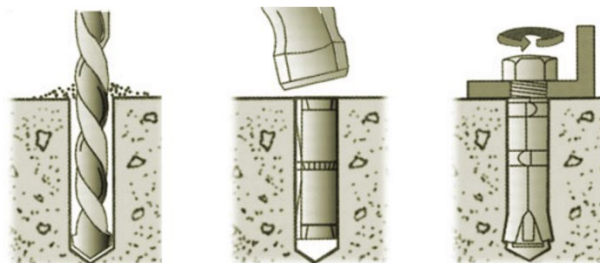

Figure 4-8 Drill holes, set Anchors, and tighten Assembly Bolts

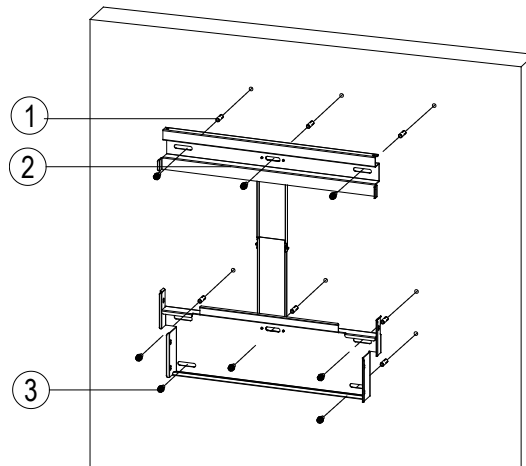

Figure 4-9 Secure the Mounting Bracket

4.2.5.2 Mechanical Installation, Method

Table 4-3 Tools Required

TOOL	DESCRIPTION
NO. 2 PHILLIPS HEAD SCREWDRIVER	Torque value of 1.6 Nm (14.2 in-lbs)
NO. 10 WRENCH	Torque value of 4 Nm (35.4 in-lbs)
NO. 3 PHILLIPS HEAD SCREWDRIVER	Torque value of 4 Nm (35.4 in-lbs)

4.2.5.3 Install the Power Head

⚠ CAUTION

Lifting Heavy Object Hazard: Proper lifting technique must be used in order to avoid injuries. The Power Head of the Solectria PVI 25TL-208, PVI-36TL-480-V2, PVI 50TL-480, AND PVI 60TL-480 weighs 123.5 lbs (56kg).

Hang the inverter on the mounting bracket as shown in Figure 4-10.

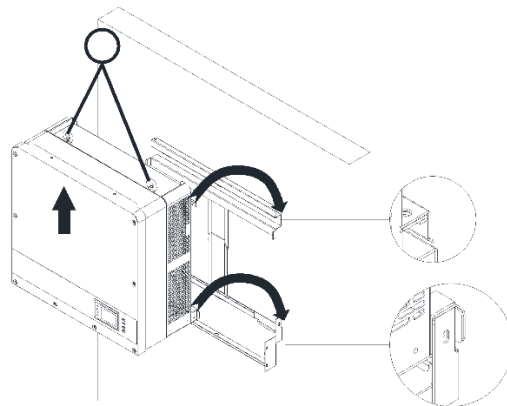

Figure 4-10 Mount the Main Enclosure on the Bracket by Lifting Sling

Lift mounting: Locate the lifting eyes at the top of the inverter. Use a sling rope or bar (inserted through both lifting eye nuts) to lift the inverter onto the bracket. The minimum angle between the two sling ropes should be less than 90 degrees.

Manual mounting: Two people are required to safely lift the inverter by the grab handle positions marked in Figure 4-11 and mount it onto the bracket.

CAUTION

Heavy Object: The main PVI 25TL-208, PVI-36TL-480-V2, PVI 50TL-480, and PVI 60TL-480 inverter section is 123.5 lbs (56 kg). Please ensure the mounting bracket is properly installed before hanging the inverter on the bracket. It is recommended to have at least 2 people mount the inverter due to the weight of the equipment.

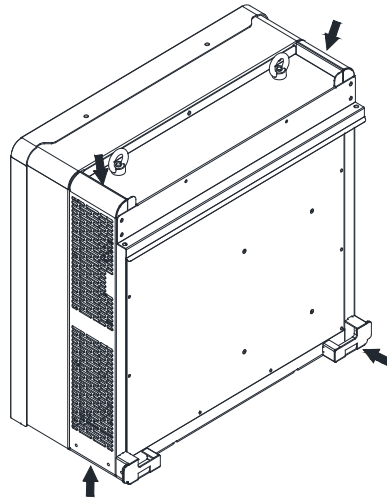

Figure 4-11 Grab Handle Position

4.2.5.4 Install the Wiring Box

NOTICE!

It is not advisable to leave the Wiring Box Installed without the Power Head:

If it is absolutely necessary to have the Wiring Box installed without the Power Head, keep the bulkhead connector cover on or reinstall the bulkhead connector cover. The bulk head connector cover is not water tight so an additional waterproofing method is suggested until the power head is installed.

Remove screws securing the bulkhead connector cover at the top of the wiring box. Tool required: No. 2 Phillips head screwdriver

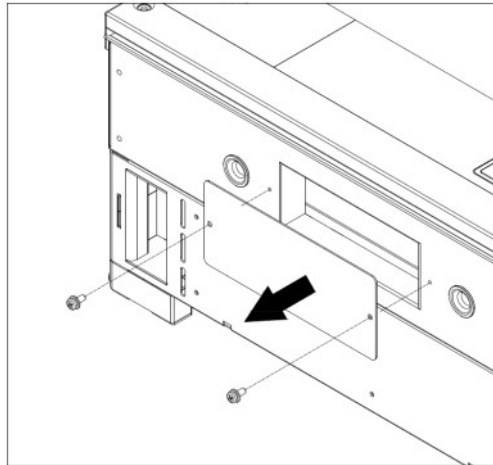

Figure 4-12 Main Enclosure Cover Plate

Remove screws securing the bulkhead cover at the top of the wiring box.

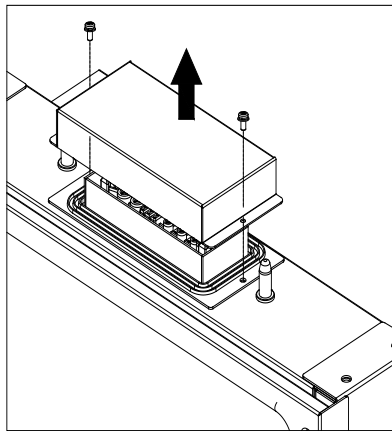

Figure 4-13 Wiring Bulkhead Cover

INFO ✓

The covers shown above do not have waterproof function. THEY ARE NOT WATER TIGHT.

Save the bulkhead connector cover and screws and attach the cover to the left side of the wiring box after the wiring box is attached to the inverter enclosure. Covers may be required in the future if an inverter or wiring box is to be removed during servicing.

Tool required: No.2 Phillips head screwdriver

4.2.5.5 Secure the Power Head to the Wiring Box

Secure the wiring box to the main enclosure by using the M6x18 screws (4pcs) to fasten the wiring box (see Figure 4-14).

Tool required: No. 10 Wrench or No. 3 Phillips head screwdriver, torque value of 4 Nm (35.4in-lbs).

 **WARNING**

Incorrect Torque Leads to Improper Bonding: Ensure the M6x18 screws (4 pcs) for Section 4.2.5.5 are properly torqued at 4 Nm (35.4 in-lbs). This connection provides an electrical grounding bond of the Wiring Box to the upper/main enclosures.

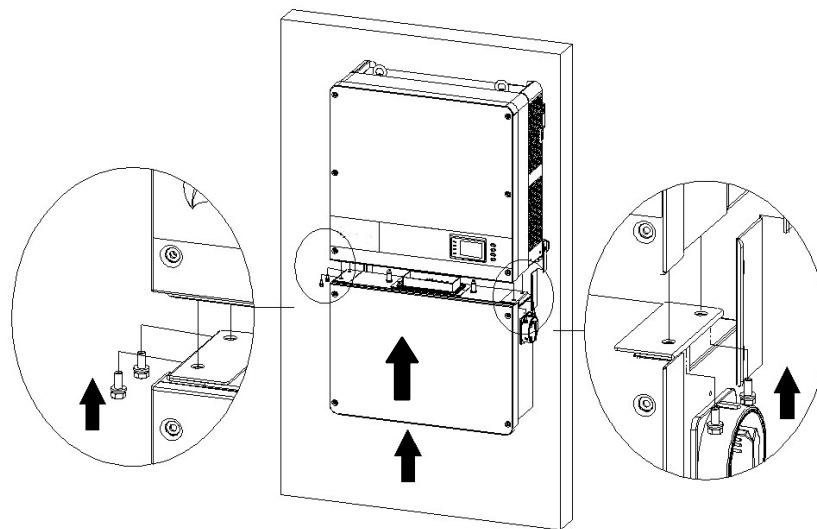

Figure 4-14 Securing Wiring Box to Power Head

4.2.5.6 Attach Enclosures to Mounting Bracket

Attach the main enclosure and the Wiring Box to the mounting bracket with **M6x18 screws** (6 pcs) as shown in Figure 4-15. Tool required: No.3 Phillips head screwdriver, torque value of 4N.m (35.4in-lbs)

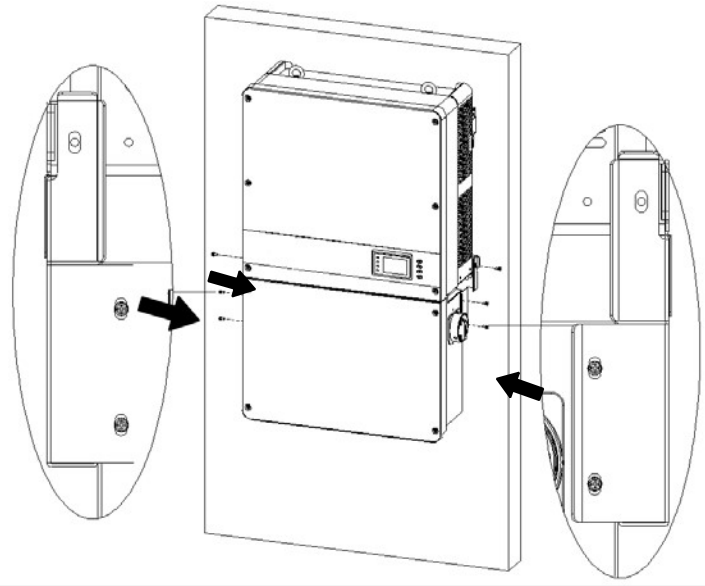

Figure 4-15 Secure the Main Enclosure and Wiring Box to the Bracket

4.2.5.7 Storage of Bulkhead Cover

Attach the bulkhead cover shown in Figure 4-12 to the left side of the wiring box as shown in Figure 4-16 for future use.

Tool required: No.2 Phillips head screwdriver, torque value of 1.6N.m (14.2in-lbs)

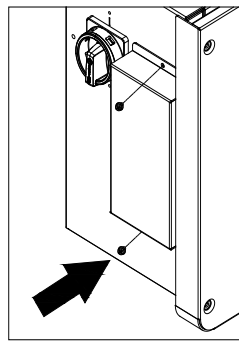

Figure 4-16 Attach Bulkhead Cover to Wiring Box

4.2.5.8 Anti-Theft Padlock (Optional)

The Yaskawa Solectria Solar PVI 25TL-208, PVI-36TL-480-V2, PVI 50TL-480, and PVI 60TL-480 inverters provide the option to install an anti-theft padlock (not included) when the installation is complete. The anti-theft padlock is used to prevent the inverter from being stolen when the equipment is installed outdoors. The inverter may be locked to the bracket, as shown in Figure 4-17.

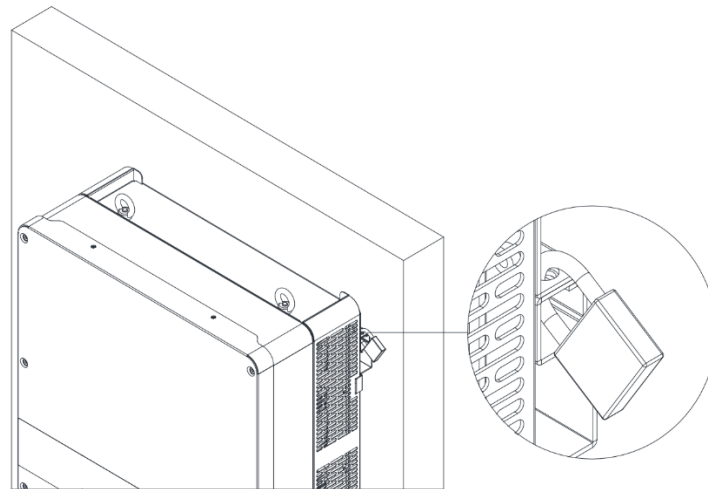

Figure 4-17 Location of Anti-Theft Padlock Hole

The anti-theft padlock shackle should meet the requirements of the dimensions shown in Figure 4-18.

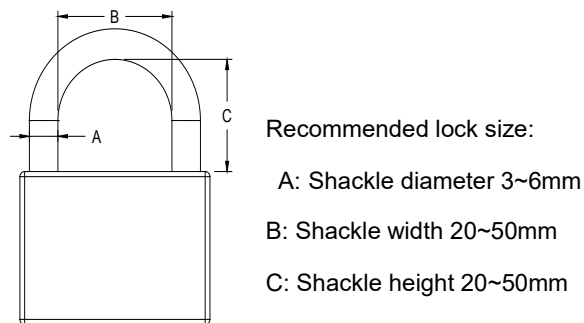

Figure 4-18 Acceptable Dimensions for Anti-Theft Padlock

4.3 Electrical Installation

DANGER

Electric Shock Hazard: Components with hazardous voltage and energy will electrocute operator. Operator shall avoid touching live components with hazardous voltage and energy. Verify the absence of voltage using an appropriately rated multimeter.

Always Wear Proper PPE: The proper Personal Protective Equipment (PPE) must be worn while working in close proximity of hazardous voltage and energy.

Conduit Installation: All conduit connections must be made in such a way as to maintain the NEMA rating of the enclosure. Failure to maintain the NEMA rating will void the warranty.

WARNING

Turn AC Switch to OFF: Verify the absence of AC voltage prior to terminating any conductors.

Turn the external AC breaker OFF: Verify the absence of AC voltage prior to terminating any conductors.

Open Fuse Holders: Verify the absence of DC voltage and current.

INFO ✓

The SOLECTRIA PVI 25TL-208, PVI-36TL-480-V2, PVI 50TL-480, and PVI 60TL-480 3-phase inverters must be installed in accordance with the National Electric Code, NFPA 70, and any State Codes or local jurisdictions. An online based Solar PV string sizing tool is available <https://solectria.com/support/string-sizing-tool/>. This is an optional design tool to help guide designers by matching the PV panel type and quantity to the inverter's power rating.

! WARNING

Prior to performing any electrical installation, ensure the M6x18 screws (4pcs) installed in Section 4.2.5.5 for mounting the Inverter onto the Bracket are properly torqued and the area under the bolt-head is clear of paint. This connection provides an electrical ground bond of the wiring box to the upper/main enclosure.

4.3.1 Removing/Replacing the Wiring Box Cover

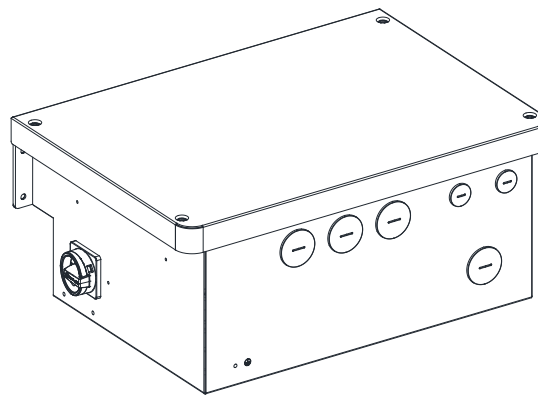

Figure 4-19 Standard and RSD Wirebox

Use a No. 3 Philips head screwdriver to remove the 4 screws on the wiring box and remove the cover. (See Figure 4-20)

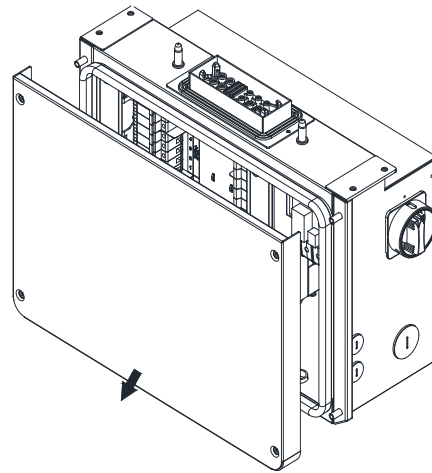

Figure 4-20 Removing the Wiring Box Cover

To reinstall the cover, replace cover and align the screws. Use a No. 3 Philips head screwdriver to secure the 4 screws on the cover. Torque to 35.4 in-lbs (4 N.m.)

4.3.2 Wiring Box

The conduit knockout locations are shown in Figure 4-21. Existing knockout holes can be enlarged by the customer keeping the center of the knockout in the same location, but no additional or new holes shall be created. If the knockout holes are enlarged by the customer, adequate room for water tight connections should be taken into consideration, and all refuse, such as metal shards, shall be removed from within the wire box prior to commissioning.

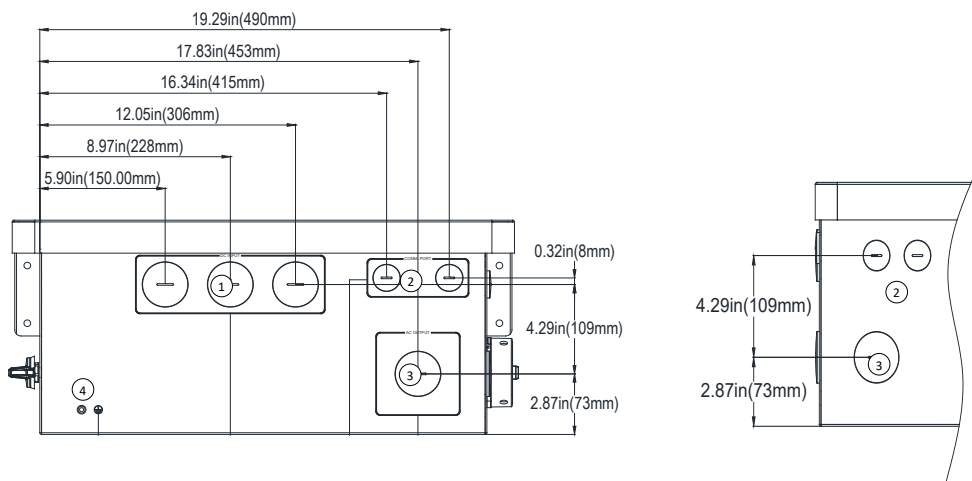

Figure 4-21 Conduit Knockout Locations on the Wiring Box

- ① Knockouts for DC input, (3) 1-1/2 inch Trade Size
- ② Knockout for communication, (2) 3/4 inch Trade Size
- ③ Knockouts for AC output, (1) 1-1/2 inch Trade Size

- ④ External ground connection point (M6)

The internal connection points for the different wiring boxes configurations are shown in Figure 4-22, Figure 4-23, and Figure 4-24. Their different connection points are labeled as follows:

- ⑤ DC Input fuse holder/terminal
- ⑥ DC SPD (Surge Protective Device)
- ⑦ Internal ground terminal
- ⑧ AC output terminal block
- ⑨ DC Input terminal (negative)
- ⑩ RSD transmitter

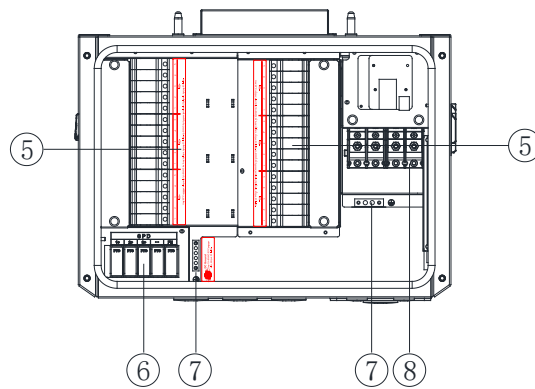

Figure 4-22 Internal Connection Points within the Standard Wiring Box (only for PVI-36TL-480-V2 & PVI 50/60TL-480)

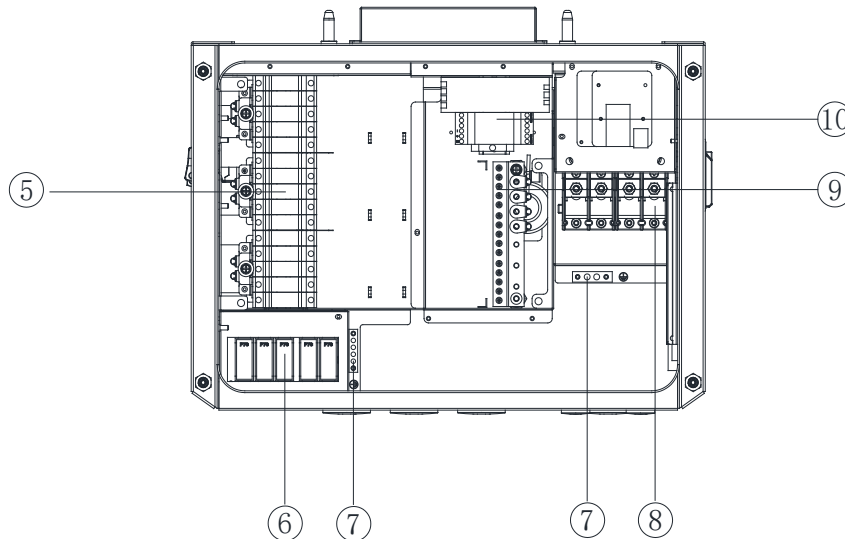

Figure 4-23 Internal Connection Points within the RSD Wiring Box (only for PVI-36TL-480-V2 & PVI 50/60TL-480)

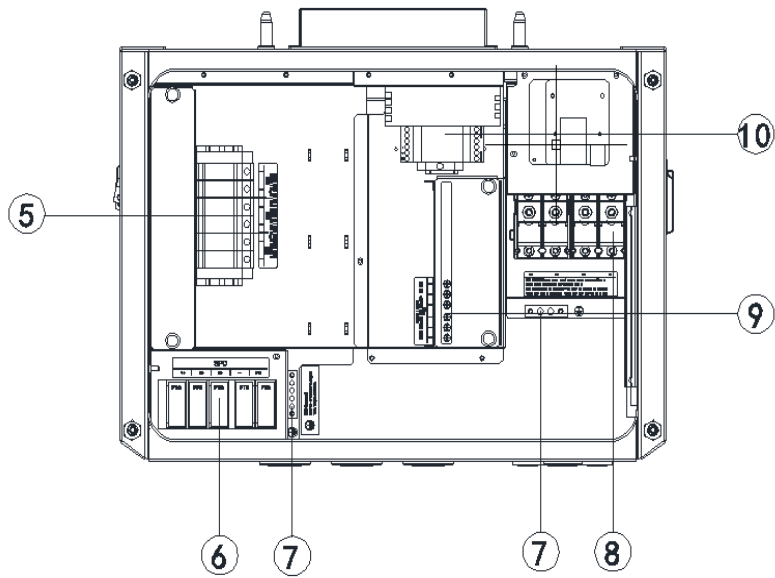

Figure 4-24 Internal Connection Points within the RSD Wiring Box (PVI 25TL-208)

Figure 4-25 shows the PVI-36TL-480-V2, PVI 50TL-480 and PVI 60TL-480 standard wiring box with the fuse bypass option. This option is used with external combiner boxes. The three zones of these inverters must stay independent and shall not be paralleled with the use of the fuse bypass terminals. See Section 4.3.3.1.4 for more details.

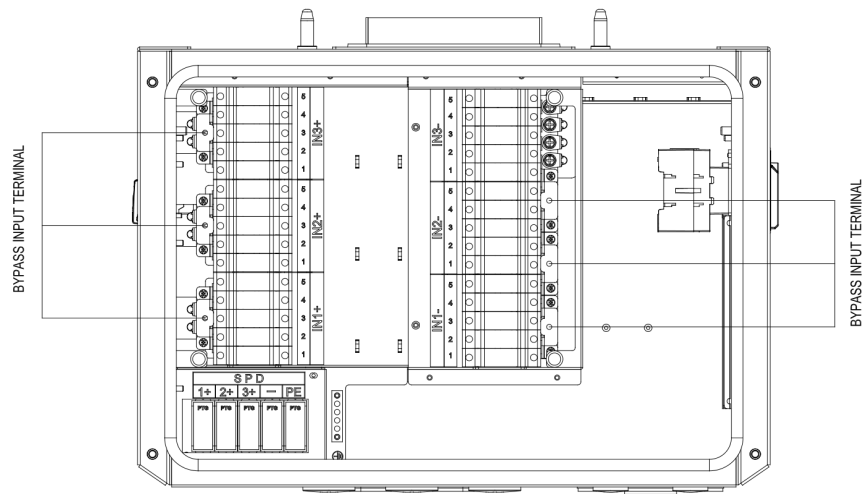

Figure 4-25 Full View of Standard Wiring Box with the Fuse Bypass Options

4.3.3 Electrical Installation DC

The SOLECTRIA PVI 25TL-208, PVI-36TL-480-V2 & PVI 50/60TL-480 inverters provide design flexibility for the installer and designer. The following section provides important information regarding the DC input specifications, wiring requirements, and installation instructions.

4.3.3.1 MPPT Zones

The SOLECTRIA PVI inverters are factory configured with MPPTs which are electrically divided into separate PV input zones: PV Input-1 (PVIn1), PV Input-2 (PVIn2) and PV Input-3 (PVIn3) (see Table 4-4).

Each PV input zone operates as a separate and independent Maximum Power Point Tracker (MPPT). Independent MPPTs can be very useful for sites with partial shading of the array or with arrays consisting of different tilt or azimuth. Each MPPT employs a method known as perturb and observe (P&O) for seeking and tracking the maximum power point along the IV curve of the PV array. During operation each MPPT will make small adjustments to the PV voltage and then execute a power measurement; if the PV power increases, further voltage adjustments in that same direction are performed until the PV power no longer increases.

NOTICE!

DC Overload: Exceeding the recommended DC to AC ratio may damage the inverter and will void the warranty. Size strings according to information in this section and all applicable electrical codes.

DC/AC Ratio and Current Limits: Both DC to AC ratio and I_{sc} limits must be observed. Failure to meet these requirements may result in damage and will void the warranty.

NOTICE!

High Irradiance Installations: In applications that may experience higher than 1000 W/m² on a regular basis, it is recommended to design a DC-to-AC ratio below the limit of 1.5 (PVI 60TL-480) and 1.7 (PVI-36TL-480-V2) and 1.8 (PVI 50TL-480 and PVI 25TL-208).

4.3.3.2 String Mismatch

To ensure optimal performance, the number of PV modules per source circuit should be identical within a given MPPT zone. However, PV input power may be unbalanced between the MPPT zones. See Figure 4-26 for string/zone combinations.

- DESIGN TIP #1: Note the max input power per MPPT zone and the total inverter max PV power (see Table 4-4)
- DESIGN TIP #2: When designing the PV system, ensure each PV source circuit within a single PV input zone includes the same module type (manufacturer and rating), series module count, and module orientation (tilt and azimuth) to maximize MPPT performance and energy harvest.
- DESIGN TIP #3: The difference in the number of source circuits for each MPPT should not exceed one (i.e. PVIn1:PVIn2 = 3:2). Uneven distribution of strings among MPPTs (e.g. PVIn1:PVIn2 = 3:1), for example, is not recommended and may result in unnecessary power clipping.

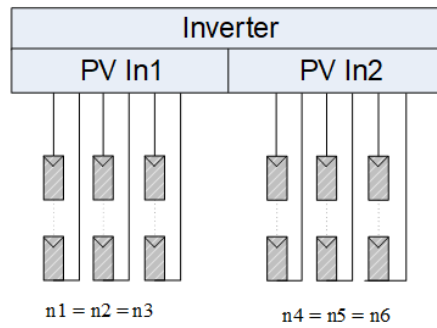

Figure 4-26 Independent MPPT Zones Only

! WARNING

Unequal String Lengths and Module Mismatch: Opening fuses under load can cause a hazardous condition. It is strongly recommended to avoid unequal string lengths within a zone and module mismatch.

Rapid Shutdown Devices when used, must be used on all MPPTs.

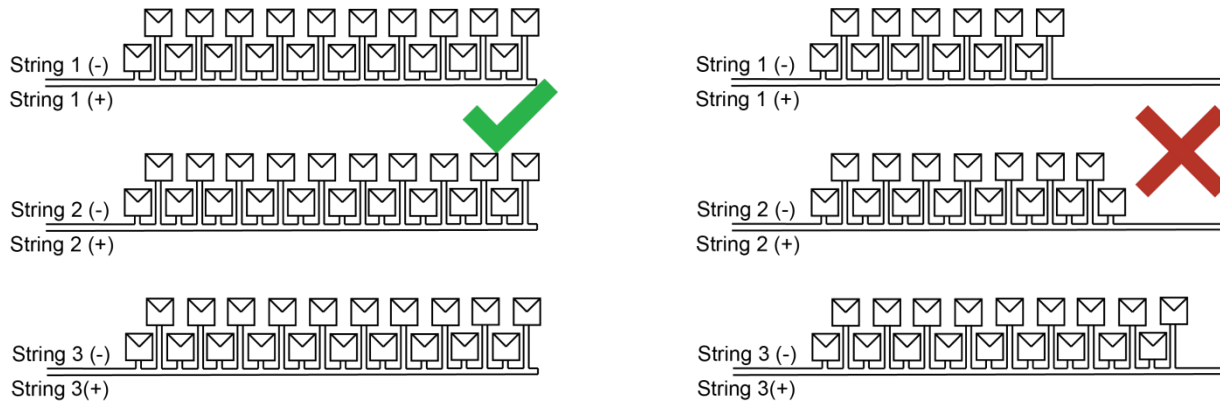

Figure 4-27 Matched (Left) and Mismatched (Right) String Sizes within a Zone

4.3.3.3 DC Connection Specifications

The voltage rating of the DC conductors must meet or exceed 1000VDC and be rated at no less than 90°C (194°F). All electrical conductors must meet the requirements of the NEC and local electrical codes. Although these inverters operate with ungrounded PV arrays, the PV system requires a DC equipment grounding conductor (EGC) to ensure operational safety. The grounding busbars are electrically bonded by way of the inverter chassis.

Table 4-4 DC Input Specifications

DC INPUT	PVI 25TL-208	PVI-36TL-480-V2	PVI 50TL-480	PVI 60TL-480
MAXIMUM POWER INPUT VOLTAGE RANGE	480-850 VDC	400-850 VDC	480-850 VDC	540-850 VDC
OPERATING VOLTAGE RANGE (MPPT)	200-950 VDC	200-950 VDC	200-950 VDC	200-950 VDC
START-UP VOLTAGE / POWER	330 V / 80 W	330 V / 80 W	330 V / 80 W	330 V / 80 W

MAXIMUM RATED PV INPUT	17 kW per zone (45 kW total)	22.44 kW per zone (61.2 kW total)	33 kW per zone (90 kW total)	33 kW per zone (90 kW total)
ABSOLUTE MAXIMUM INPUT VOLTAGE	1000 VDC	1000 VDC	1000 VDC	1000 VDC
NUMBER OF MPP TRACKING ZONES	3	3	3	3
NUMBER OF PV SOURCE CIRCUITS (FUSED INPUTS)	2 per MPPT zone; 6 total	5 per MPPT zone; 15 total	5 per MPPT zone; 15 total	5 per MPPT zone; 15 total
MAXIMUM PV CURRENT (ISC X 1.25) PER ZONE / TOTAL	45 A / 90 A	68 A / 204 A	68 A / 204 A	68 A / 204 A
MAXIMUM RECOMMENDED DC-TO-AC RATIO	1.8	1.7	1.8	1.5

Select the DC conductor size and material for the inverters according to the following configuration table:

Table 4-5 DC Conductor and Torque Specifications

	WIRE MATERIAL	ACCEPTABLE CONDUCTOR SIZES
PVI 25TL-208	75/90°C Copper only when terminating to the fuse holders. Terminals are 90 ° C rated.	14 to 6 AWG
PVI-36TL-480-V2 & PVI 50/60TL-480	Copper only when terminating to the fuse holders. Terminals are 90 ° C rated.	14 to 6 AWG
PVI-36TL-480-V2 & PVI 50/60TL-480 AND BYPASS TERMINAL	Copper or Aluminum when using the Bypass Terminal kit accessory. Terminals are 90 ° C rated.	6 to 2 AWG

INFO ✓

Even though the SOLECTRIA PVI 25TL-208, PVI-36TL-480-V2, PVI 50TL-480, and PVI 60TL-480 3-Phase Inverters are designed operate with ungrounded arrays, the PV system requires a DC equipment grounding conductor (EGC) to ensure operational safety. The grounding busbars are electrically bonded by way of the inverter chassis.

4.3.3.4 PV Fuses

The SOLECTRIA PVI 25TL-208, PVI-36TL-480-V2, PVI 50TL-480, and PVI 60TL-480 inverters are shipped with factory installed touch-safe fuse holders and 20 A fuses as factory standard. Ensure that the appropriate fuse values are used for the conductors in the PV source circuit and in accord with NEC 690.9. Yaskawa Solectria does not supply fuses.

- (1) Each DC input conductor for the PV string requires fuse protection. (2014 NEC and earlier editions only)
- (2) The voltage rating of the fuse must be at least 1000VDC.
- (3) The ampere rating of the fuse is generally selected as $1.56 \times$ module Isc of the PV string. Refer to NEC 690.8 for circuit sizing and current requirements.

Table 4-6 DC Fuse selection

	BRAND	15A	20A	25A	30A
25/36-V2/50/60 KW	Mersen	HP10M15	HP10M20	HP10M25	HP10M30
		15A/1000V	20A/1000V	25A/1000V	30A/1000V
	Sinofuse	RS308-PV3E15A	RS308-PV3E20A	RS308-PV3E25A	RS308-PV3E30A
		15A/1000V	20A/1000V	25A/1000V	30A/1000V

Table 4-6 shows the different models of fuses that are acceptable replacement fuses in the PVI 25TL-208, PVI-36TL-480-V2, PVI 50TL-480, and PVI 60TL-480 inverters wire box fuse holders. UL listed, 1000VDC, 15A or 20A, 10x38mm cylindrical, PV fuses from the following manufacturers are recommended as replacement fuses when necessary: Mersen or Sinofuse.

The touch safe fuse holders and wirebox internal factory wiring are designed to accept 15A, 20A, 25A, or 30A rated fuses. The larger rated fuses may be required for combined input strings; for example, when Y branch connectors are used with DC field wiring to reduce PV source circuit home runs. Yaskawa Solectria Solar allows replacement of the factory installed 20A fuses with appropriate ampere ratings, however Yaskawa Solectria Solar does not provide nor stock these fuses.

NOTICE!

When installing replacement 25A or 30A fuses, these fuses may not be installed in adjacent fuse holders. An empty or unused fuse holder must be positioned between each 25A/30A fuse within each MPPT.

Use of fuses from other manufacturers or incorrectly sized fuses can cause either equipment damage or create an unsafe working condition. Any damage resulting from use of incompatible fuses is not covered by the Yaskawa Solectria warranty

NOTICE!

String Length: The recommended fuse values are configured based on the condition that the input strings are the same (module type and length).

Temperature Rating: The temperature rating of the fuse holder terminals is (90°C).

INFO ✓

Due to improved ground-fault protection requirements in PV systems, the 2017 version of the NEC allows for a single overcurrent protection device in either the positive or negative polarity. If local codes or jurisdictions require fuse protection for each DC input conductor (i.e. NEC 2014 or earlier), additional fusing shall be installed for the conductors connected to the negative (-) DC input terminal of the Solectria PVI 25TL-208,

PVI-36TL-480-V2, PVI 50TL-480, and PVI 60TL-480 inverters. The voltage rating of the fuse must be at least 1000V_{DC}. In-line fuses can be used for this purpose. Any additional fusing must be installed outside of the inverter.

 **WARNING**

Use of different fuses or wrongly sized fuses can cause damage to equipment or create un-safe working conditions. Any damage resulting from incompatible fuses is **not** covered by warranty.

4.3.3.5 DC Conductor Connection

To ensure the optimum performance of the inverter, please read the following guidelines before performing any DC connections.

- Confirm the maximum open circuit voltage of the PV modules is lower than 1000V_{DC} under any conditions.
- Confirm that the PV modules for each MPPT within the inverter are of the same type and specification before connection.
- Ensure correct polarity of the PV Strings before terminating the DC source circuits. Referring to Figure 4-28, the wiring from the PV string pairs must be checked according to the following steps:
 - Use a multi-meter to measure the PV strings' conductor ends and check the polarity.
 - The positive (+) terminal of the conductor should match the positive (+) terminal of inverter's DC input.
 - The negative (-) terminal of the conductor should match the negative (-) terminal of inverter's DC input.

NOTICE!

DC Polarity Check: It is important to use a multi-meter to check the polarity of the DC source conductors to avoid any risk of reverse polarity.

 **WARNING**

A reversed string is not protected by the inverter and can cause severe damage to equipment and personnel. A reversed string is extremely hazardous and will result in a blown fuse when the irradiation is high. The voltage across the blown fuse can be as much as two times V_{oc} and could prevent proper fuse operation resulting in a fire.

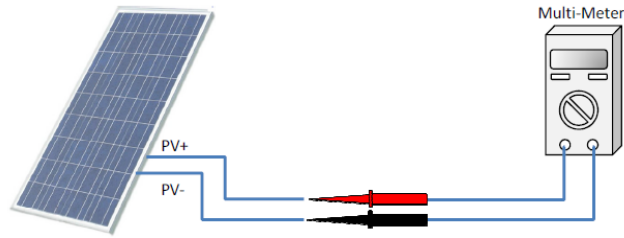

Figure 4-28 Polarity Check

INFO ✓



Wire Ferrules: 10 AWG wire ferrules are intended to preclude the onset of stray/loose wire strands or “bird caging” of the conductor during installation and improve the integrity of the termination. The use of the wire ferrules is not mandatory and does not void the product warranty if not used.

Ferrules are not provided by Yaskawa Solectria Solar.

4.3.3.6 DC Fuseholder Torque Specification

The inverter wiring box may be assembled using fuse holders supplied by either Sinofuse or Mersen (Ferraz Shamut). The touch safe fuse holders have unique terminal torque values specified by their manufacturers. The fuse holders can be identified by color markings; Sinofuse-White, and Mersen-Orange. See Table 4-7 for specified torque values.

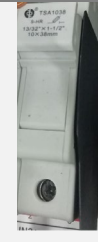
Table 4-7 DC Fuse Holder Torque Value by Manufacturer

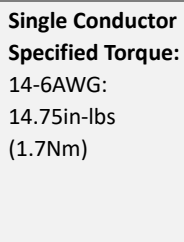
SINOFUSE TSA1038	MERSEN USM1	NEG BUSBAR
		
Single Conductor Specified Torque: 14-6AWG: 14.75in-lbs (1.7Nm)	Single Conductor Specified Torque: 14-6AWG: 14.75in-lbs (1.7Nm)	Single Conductor Specified Torque: 14-6AWG: 14.75in-lbs (1.7Nm)

⚠ WARNING

Failure to apply proper torque to the fuse holder terminals may result in an improper conductor termination and cause excessive heat or fire.

4.3.3.1DC Connection for Standard and RSD Wire Box

4.3.3.1.1 Using the 1-1/2 inch openings

Remove the factory installed liquid-tight plugs from the DC knockout holes in the Wire Box and install 1-1/2 inch Trade Size conduit and conduit fittings. If the use of smaller conduit is desired, use proper weather-tight reducing bushings to ensure the Wire Box maintains its NEMA 4X rating. If larger conduit than 1-1/2 inch is required, either use reducers or create larger concentric holes from the knockout holes provided. However, care must be taken to ensure that water tight seals can be made with the larger knockouts. No new holes in unspecified areas are allowed or it will impact the NEMA 4X rating and wire box warranty. Confirm all fittings are properly tightened and route the DC source circuit conductors through the conduit into the Wire Box.

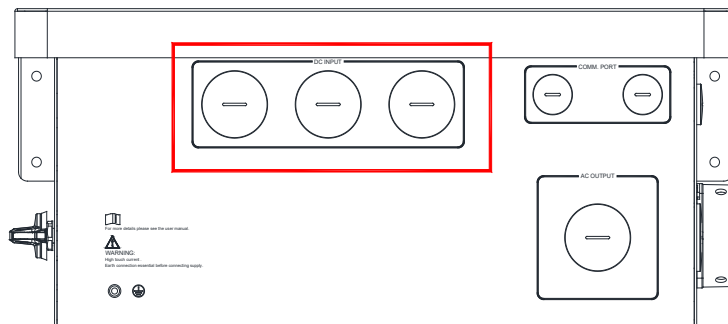

Figure 4-29 DC Input connection

Table 4-8 DC Electrical Installation DC, Tools Required

TOOL	DESCRIPTION OF USE
#2 PHILLIPS-HEAD SCREWDRIVER	Fuse holder Terminal
DIAGONAL PLIERS OR CABLE CUTTERS	Cut cable
WIRE STRIPPING PLIERS	Remove conductor insulation
TORQUE DRIVER	Torque terminals to specifications
CRIMPING PLIERS / TOOL	Ferrule crimp (optional)

INFO ✓

Rapid Shutdown: Refer to the connection method of standard wiring box. The RSD transmitter sends the powerline communications (PLC) signal through the negative conductors via the busbar. AC power to the inverter is required in order to turn on the transmitter and signal the array.

4.3.3.1.2 Terminate at fuse holders

Strip approximately 1/2 inch of the cable jacket from the end of the source circuit conductor. Insert the conductor into the fuse holder terminal ensuring the stranding of the conductor remains firmly twisted and does not separate. Tighten the screw clamp to the torque specified in Table 4-7. Continue terminating the remaining source circuits in this manner for each MPPT zone (PVI_{n1}, PVI_{n2}, PVI_{n3}).

Please note that the Yaskawa Solectria Solar PVI 25TL-208, PVI-36TL-480-V2, PVI 50TL-480, AND PVI 60TL-480 module-level rapid shutdown (RSD) ready wire boxes only contain fuse holders for the positive DC conductors. Follow instructions in Section 4.3.3.1.3 below for the negative conductors in the RSD wire boxes that will be connected to the busbar.

4.3.3.1.3 Rapid Shutdown (RSD) Ready Wire Box Negative DC Conductor Terminations

The RSD Wire Box only contains fuse holders for the positive DC conductors. Follow instructions in Section 4.3.3.1.2 for the positive conductors. The negative DC conductors are to be terminated on the busbar. Strip approximately 1/2 inch of the cable jacket from the end of the string conductor. Insert the conductor into the busbar ensuring the stranding of the conductor remains firmly twisted and does not separate. Tighten the screw to the torque specified in Table 4-7. Continue terminating the remaining source circuits in this manner for each MPPT (PVIn1, PVIn2, PVIn3).

4.3.3.1.4 Fuse Bypass Terminal

The Fuse Bypass Terminal option is for the PVI-36TL-480-V2, PVI 50TL-480 and PVI 60TL-480 wire boxes. Fuse Bypass Terminals are available as an optional accessory when external PV string fused combiners are used. The Bypass Terminals allow for larger single conductors to be terminated at each MPPT within the wiring box, bypassing the input fuses as shown in Figure 4-25. See Section 10.1 Fuse Bypass Terminals for installation information. Please note that this option is not available for the PVI 25TL-208 inverters.

Before terminating the PV conductors, verify connector specifications and always verify polarity to avoid risk of reverse polarity.

4.3.4 Electrical Installation AC

The SOLECTRIA PVI-36TL-480-V2, PVI 50TL-480, and PVI 60TL-480 are 480VAC, 60Hz, 3-phase grid tied inverters. The SOLECTRIA PVI 25TL-208 is a 208VAC, 60Hz, 3-phase grid tied inverter. The inverter will not operate as specified when installed to any other grid voltage or frequency. This section includes important information regarding the AC grid connection, wiring requirements, and installation instructions.

INFO ✓

String Sizing Tool: Yaskawa Solectria Solar offers a String Sizing Tool to help customers design their PV string sizing at <https://www.solectria.com/support/string-sizing-tool/>

4.3.4.1 Transformer Configurations

CAUTION

Improper Transformer Configuration: Inverter will not run and may have hazardous current. Connect transformer in specified configurations only (see Figure 4-30).

INFO ✓

Grid Mismatch: If the grid does not match the requirements of the inverter, the inverter will not start. Check with your local electric utility before selecting a grid profile. The system must comply with National Electrical Code ANSI/NFPA 70 and with all local rules and safety regulations before the inverter can be operated.

Yaskawa Solectria Solar PVI line three-phase transformerless inverters prefer a wye configured service with solidly grounded neutral. When needed, a floating WYE or floating delta service is permissible. Please note that when pairing these inverters with a floating WYE or floating delta service, the inverter can only provide DC ground fault detection. It is the customer’s responsibility to provide AC ground fault detection external to the inverter to comply with NEC 250.21. Table 4-9 shows the allowable inverter side transformer winding configurations.

Table 4-9 Transformer Specifications (Inverter facing)

INVERTER	TRANSFORMER WINDING (INVERTER SIDE)			
	WYE Floating*	WYE Grounded	Delta Floating*	Delta Grounded
PVI 25TL-208	YES	YES	YES*	NO
PVI-36TL-480-V2 PVI 50TL-480 PVI 60TL-480	YES	YES	YES*	NO

* Customer provided external Ground Fault detection on AC side is required to comply with NEC 250.21 code. Only DC Ground Fault detection provided by the inverter with floating WYE or floating Delta interconnection configurations.

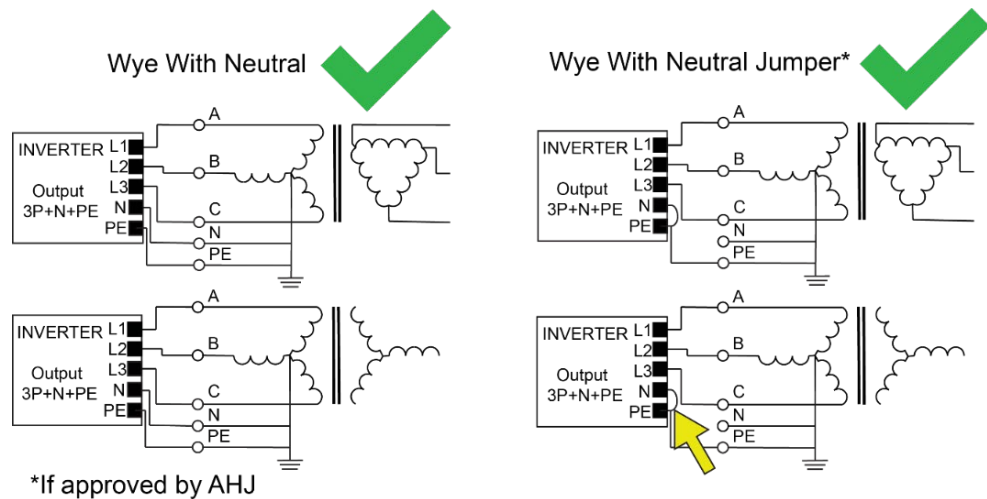

Figure 4-30 Permitted Transformer Configurations

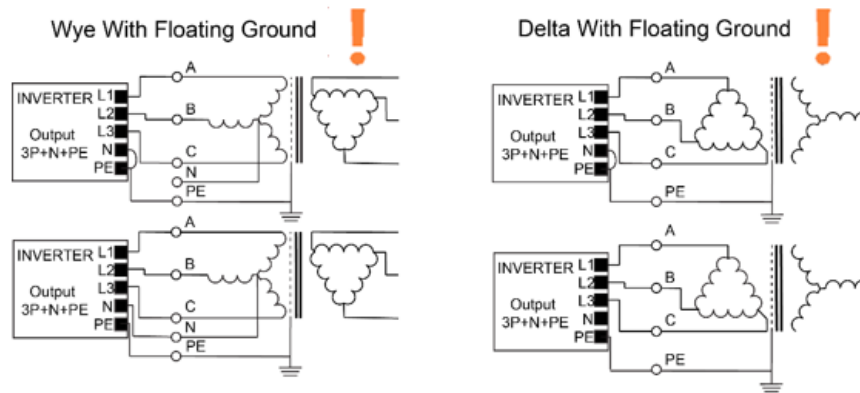

Figure 4-31 Transformer Configurations Permitted with Added Requirements from Installer

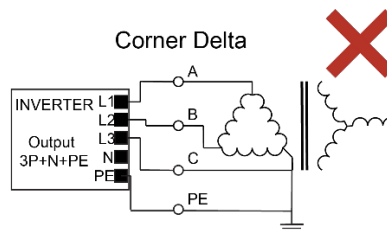

Figure 4-32 Transformer Configurations NOT Permitted

- If the upstream transformer is a WYE on the inverter winding, the Neutral must be grounded or additional ground fault detection must be installed. The Neutral on the Utility Side (H0) and Inverter Side (X0) may be connected internally and brought out as one terminal in the LV compartment and labeled (H0X0).
- Transformer short-circuit impedance ($Z\%$) should be equal to or less than 6%.
- Transformer VA rating must be at least 100% of the sum of the connected inverter VA ratings.
- It is recommended that the transformer VA rating be selected based on IEEE C57.159-2016 *Guide on Transformers for application in Distributed Photovoltaic (DPV) Power Generation Systems*. It is the responsibility of the system designer to determine and take in account the reliability of the transformer or other system parameters.
- The transformer does not require a static shield.
- The maximum number of inverters connected to a single transformer is 70.
- The recommended maximum voltage-drop on the Inverter to Point of Common Coupling (to the grid) is 2% at full load – including conductor temperature considerations. Voltage drop greater than 2% may require changing the transformer tap or as a last resort adjusting the GridMaxVolt trip point settings.

A complete and most up to date guide for transformer requirements can be found in the Application Note: Interconnection Guidelines for Yaskawa Solectria Solar PVI Transformerless Inverters found at:

<https://www.solectria.com/support/documentation/>. The application note interconnection requirements take precedence over the requirements stated in this manual.

4.3.4.2 Neutral Requirements

The physical neutral conductor from the inverter to the point of interconnection is optional, but not recommended. It is used by the inverter for voltage sensing only and does not carry current. Therefore, the neutral conductor size may be reduced to a size no smaller than the EGC. These inverters have their ground and neutral terminals bonded internally.

NOTICE!

Neutral to Ground Jumper: Do not use a jumper between neutral and ground in the inverter wire box (electrical panel or transformer). Using a jumper with the neutral conductor connected may result in damage and void the warranty.

4.3.4.3 Electrical Installation AC, Method

⚠ DANGER

Electric Shock Hazard: Components with hazardous voltage and energy will electrocute operator. Operator shall avoid touching live components with hazardous voltage and energy. Verify the absence of voltage using an appropriately rated multimeter.

Always Wear Proper PPE: The proper Personal Protective Equipment (PPE) must be worn while working in proximity to hazardous voltage and energy.

Conduit Installation: All conduit connections must be made in such a way as to maintain the NEMA 4X rating of the enclosure. Failure to maintain the NEMA rating will void the warranty.

This section includes instructions to connect the AC conductors to the inverter and grounding options.

Table 4-10 Electrical Installation AC, Tools Required

TOOL	DESCRIPTION OF USE
5MM FLATHEAD SCREWDRIVER	Internal grounding bar
#3 PHILLIPS-HEAD SCREWDRIVER	External grounding
14MM HEX SOCKET HEAD WRENCH	AC terminal block
DIAGONAL PLIERS OR CABLE CUTTERS	Cut cable
WIRE STRIPPING PLIERS	Remove conductor insulation
CRIMPING PLIERS / TOOL	Crimp terminals

⚠ WARNING

Turn AC Switch to OFF: Verify the absence of AC voltage prior to landing any conductors.

Turn the external AC breaker OFF: Verify the absence of AC voltage prior to terminating any conductors.

4.3.4.3.1 Use the 1-1/2 inch knockouts

Remove the liquid-tight hole-plug from the right side or bottom of the AC input portion of the wiring box to install 1-1/2 inch Trade Size conduit and conduit fittings. Then route the cables through the conduit and into the wiring box.

If the use of smaller conduit is desired, use a proper weather-tight reducing bushing to ensure the Wire Box maintains its NEMA 4X rating. If larger conduit than 1-1/2 inch is required, either use a reducer or create a larger concentric hole from the knockout holes provided. However, care must be taken to ensure that water tight seals can be made with the larger knockouts. No new holes in unspecified areas are allowed or it will impact the NEMA 4X rating and wire box warranty.

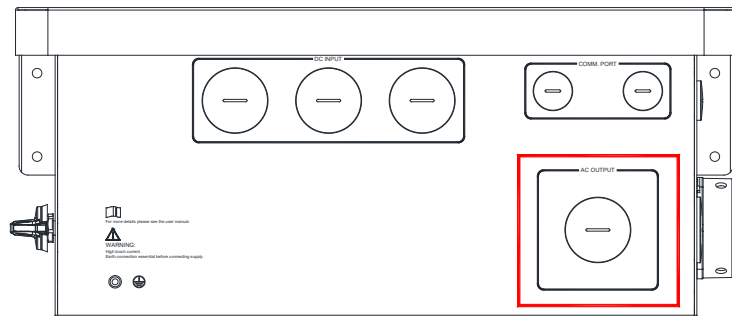

Figure 4-33 AC Input connection

NOTICE!

Grounding Conductors: Terminate the grounding conductors prior to terminating the AC cables.

4.3.4.3.2 Grounding and Bonding

The inverter provides one grounding connection on the AC side and one bonding location. These configurations are illustrated in Figure 4-34.

- A. Grounding via the ground busbar (left) [1]. This is required for grounding the equipment by running the EGC with the ungrounded conductors.
- B. Bonding via the external grounding point (right) [2]. The external bonding connection is provided in case the inverter/mount needs to be bonded to a metallic structure on which it may be mounted.

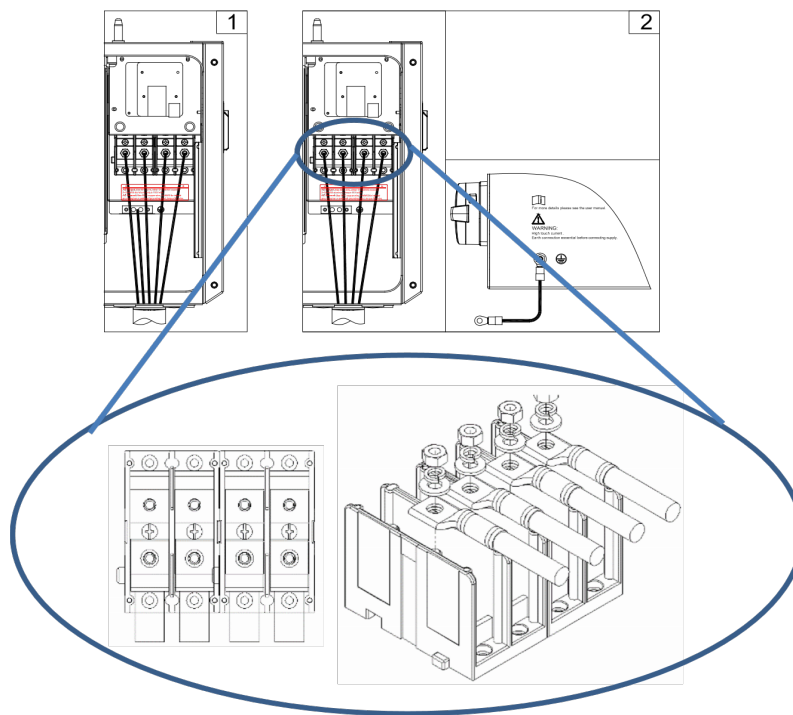

Figure 4-34 AC Output and Ground Cable Connection

Table 4-11 Torque and Conductor Specifications

CONNECTION POINT	CONDUCTOR RANGE	TORQUE VALUE
AC OUTPUT TERMINAL BLOCK	L1/L2/L3:	14.25 N-m (126 in-lbs)
	6 - 3/0AWG (75/90°C Cu)	
	6 - 3/0AWG (90°C Al)	
INTERNAL GROUNDING BAR	Neutral:	5.65 N-m (50 in-lbs)
	8 - 3/0AWG (75/90°C Cu/Al)	
EXTERNAL GROUNDING POINT	6-4 AWG (CU)	5.65 N-m (50 in-lbs)

The AC Terminals are 90°C rated. The maximum acceptable conductor size that may be terminated to the AC output terminal is restricted based on the compression lug maximum dimensions shown in Figure 4-36.

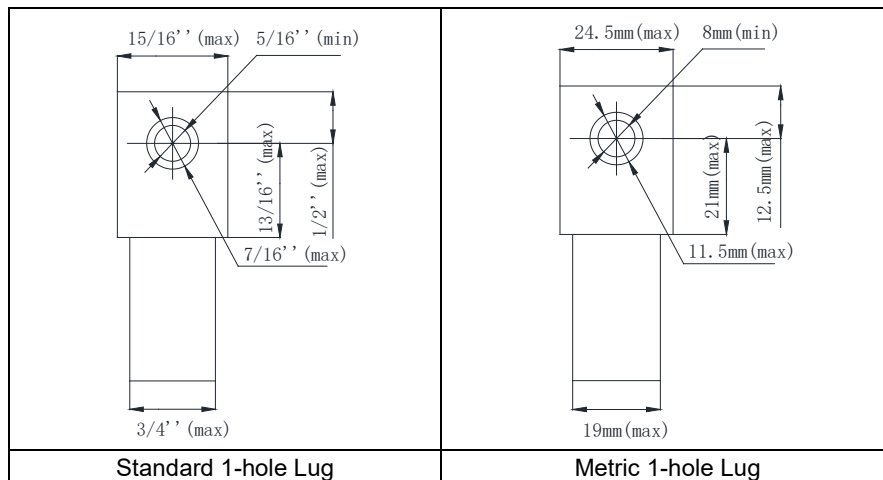

Figure 4-35 Compression Lug (OT Terminal) maximum dimensions

INFO ✓

The neutral conductor from the inverter to point of interconnection (POI) is optional. The function of the neutral, when used, is to provide a point of reference for measurement purposes that is essentially at ground potential. The neutral conductor is for control or measurement purposes only, and therefore may be sized according to NEC section 705.95(B). The ground conductor (PE) is sized to section 250.122.

Use the OT type terminal to connect the AC conductors to the AC terminal block and connect the PE (GND) cable to the grounding terminal block. The neutral conductor is optional. While the inverter may be wired as a 3-wire or 4-wire connection, the PE ground is ALWAYS required. When terminating the ground at the busbar a ferrule is recommended but not required. (See the 1st diagram in Figure 4-35) Set up the conductors referring to Figure 4-35. End ferrules and OT type terminals are not provided by Yaskawa Solectria Solar.

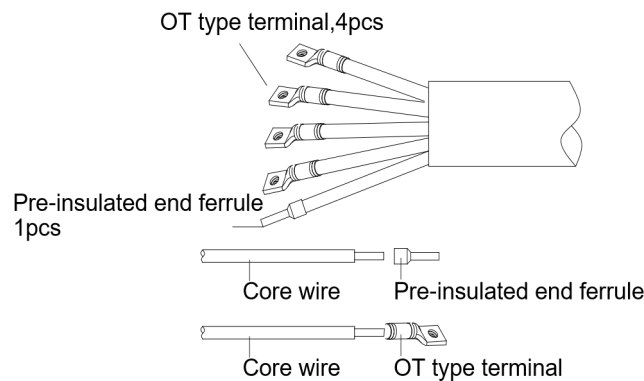

Figure 4-36 AC Output and Ground Cable Setup

When bonding the inverter/mount to a metallic structure is required, use an OT type terminal to connect the ground conductor to the external bonding point at the bottom of the wiring box. The bonding point is located at the bottom of the Wire Box as shown in Figure 4-37.

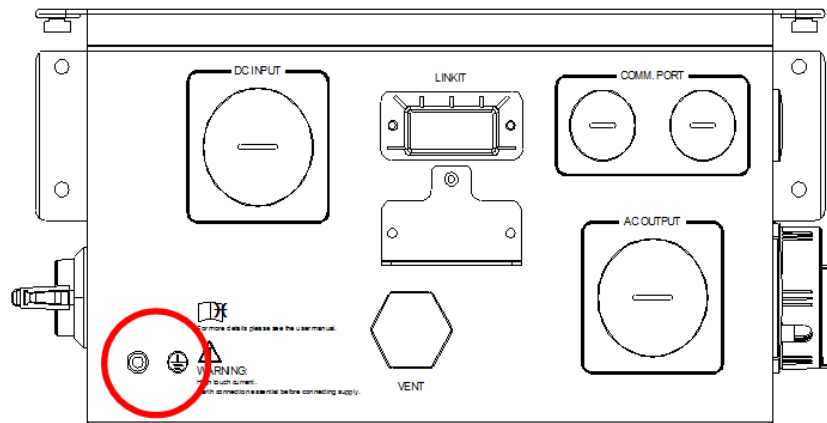

Figure 4-37 Bottom of Wiring Box: External Grounding Point Location

NOTICE!

Order of Connection Conductors: Always connect the Equipment Grounding Conductor (EGC) before terminating any of the AC conductors.

When the output of the inverter is connected to the grid, an external AC circuit breaker is required to be installed to safely disconnect the inverter from the grid should an overcurrent event occur.

Table 4-12. Selecting a breaker of another size may either result in nuisance tripping or rejection from the AHJ.

Table 4-12 Specification of AC Breaker Selection

INVERTER	MINIMUM AC OCPD	MAXIMUM AC OCPD
SOLECTRIA PVI 25TL-208	90A	125A
SOLECTRIA PVI-36TL-480-V2	60A	125A
SOLECTRIA PVI 50TL-480	50KVA= 80A 55KVA= 90A	125A, suggested
SOLECTRIA PVI 60TL-480	60KVA= 100A 66KVA= 100A	125A, suggested

4.3.4.4 Use of Aluminum Conductors

The AC terminals in the SOLECTRIA PVI 25TL-208, PVI-36TL-480-V2, PVI 50TL-480, and PVI 60TL-480 are dual rated by UL for use with copper and aluminum conductors. When using aluminum conductors it is important to prepare the conductors properly to prevent oxidation and overheating. Always use industry approved best practices to install these conductors. Suggested steps to prepare and terminate the aluminum conductors are listed below.

- a) Strip insulation from the aluminum conductor.
- b) Remove the oxidation from the connection area of the aluminum conductor using a wire brush or other abrasive means.



Figure 4-38 Preparing Aluminum Wires Prior to Connecting

- c) Immediately apply a UL listed oxide-inhibiting compound, such as Noalox.
- d) If the connection is not made within 30 seconds of applying the grease, repeat this process as an oxidized layer may have formed on top of the conductor. This oxidized layer is a poorer conductor than the greased aluminum.
- e) Terminate the conductor on the appropriate terminal and torque to the proper value as per Table 4-11.

NOTICE!

Use of Aluminum Conductors: Special care must be taken when using aluminum conductors. Failure to properly prepare and maintain aluminum conductors can result in overheating and property damage. Damage caused by improper use of aluminum conductors will void the warranty.

4.4 Communication Installation

The SOLECTRIA PVI 25TL-208, PVI-36TL-480-V2, PVI 50TL-480, and PVI 60TL-480 inverters support industry standard Modbus RS-485 communications.

The inverters are compatible with the Solectria's web-based monitoring platform (SolrenView) through the optional Ethernet Network Card. The Ethernet Network Card also allows for data to be sent to an online portal (YConnect Pro) that is used for remote diagnostics and automatic firmware upgrades. Third party monitoring platforms are supported via RS-485 shielded, twisted-pair connection.

This section includes important information regarding communication design requirements, wiring requirements, and installation instructions.

4.4.1 Communication Board

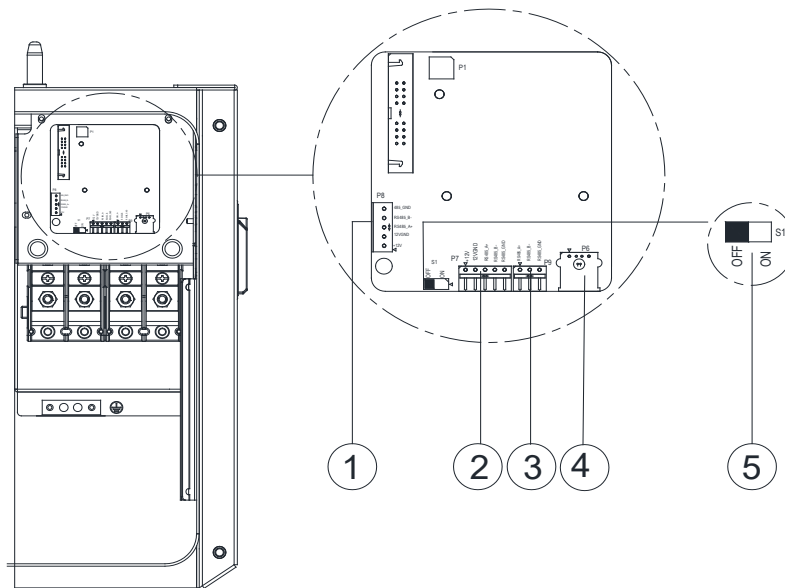

Figure 4-39 Communication Board in the Wiring Box and its connections

1. RS485 P8 (Debug only)
 1. 12V+
 2. 12VGND
 3. RS485_A+
 4. RS485_B-
 5. 485_GND
2. RS485 P7 (Communication Input)
 1. 12V+
 2. 12VGND
 3. RS485_A+
 4. RS485_B-
 5. RS485_GND
3. RS485 P9 (Communication Output)
 6. RS485_A+
 7. RS485_B-
 8. RS485_GND
4. USB Port P6: Firmware upgrade
5. Selector Switch (S1): 120Ω terminal resistor switch for communications.
 9. **ON:** Enable termination resistance
 - OFF:** Disable termination resistance

4.4.2 Ethernet Network Card

A maximum of 32 devices can be connected to this card. When provided with an internet connection, it can send data to an online portal that Yaskawa Solectria Solar can use for troubleshooting and remote diagnostic purposes. As well, customers can opt to purchase access to this portal for easy O&M of their system. It is also used for allowing the connection of a third-party monitoring system.

Connection to the Internet

Connection to the Internet with the Ethernet Network Card is strongly recommended for SOLECTRIA PVI 25TL-208, PVI-36TL-480-V2, PVI 50TL-480, and PVI 60TL-480 inverters. An internet connection will provide the user with several important features including:

- ✓ Automatic firmware updates.
- ✓ Remote diagnostics & troubleshooting.
- ✓ Access for Yaskawa Solectria Solar Technical Support & Service.
- ✓ Remote monitoring via SolrenView (optional).
- ✓ Capabilities of using the optional YConnect Pro Portal.

DANGER

Electric Shock Hazard: Disconnect the inverter from the AC grid and PV modules before removing covers or opening the equipment. Wait at least 5 minutes after disconnecting from the DC and AC sources before servicing or maintaining the inverter. Ensure hazardous high voltage and energy inside the inverter has been discharged prior to servicing.

4.4.3 Communication Conductors

Yaskawa Solectria Solar recommends the following shielded, twisted-pair cables for RS485 communications:

- ✓ Belden 9841, Belden 3106A or Southwire 58164802
- ✓ UTP CAT-5e or
- ✓ (3) 18-22AWG communications cables

It is recommended that industrial-grade shielded RS-485 cable be used in lieu of unshielded twisted pair. RS-485 communication cables are connected via the 5-pin connector to the port labeled (2) in Figure 4-39. When creating a network of multiple inverters, the cables are terminated to the same 5-pin connector and 3-pin connector. Figure 4-40 shows a single inverter communication connection in (1) and a network configuration in (2).

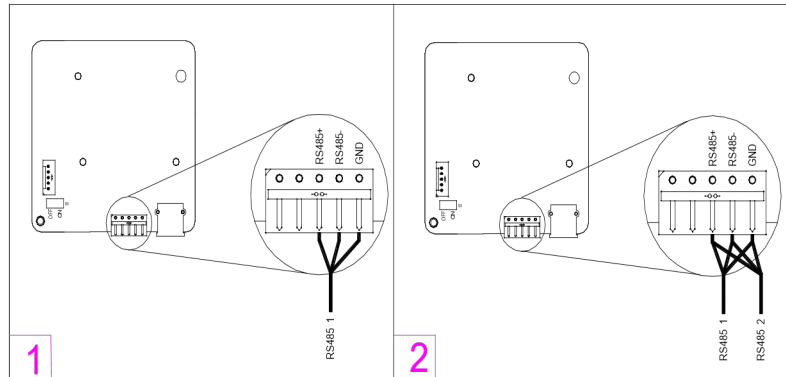

Figure 4-40 Connection of Single (1) and Multiple Inverters (2)

INFO ✓

Shielded Cable: Solar PV inverters create an electrically noisy environment that can disrupt inverter communication. It is important to use shielded cable to ensure communication is not interrupted.

Separate Communication Conductors from Power Conductors: Never run communication conductors in the same conduit as power conductors. It is important to keep communication conductors away from power conductors to reduce noise. If power conductors must intersect with communication conductors, it is preferable to have the intersection at a 90 degree angle.

4.4.4 Monitoring Compatibility

The SOLECTRIA PVI 25TL-208, PVI-36TL-480-V2, PVI 50TL-480, and PVI 60TL-480 is compatible with SolrenView and third-party Data Acquisition Systems (DAS). When using SolrenView monitoring the Ethernet Network Card is necessary. If connecting with third party monitoring providers, RS-485 connections must be used.

4.4.5 Connecting Multiple Inverters

Multiple inverters shall be connected together in a serial (daisy-chain) fashion only. It is also suggested to follow the below requirements:

- The maximum number of inverters in any single daisy chain is 32 inverters.

- Use shielded twisted pair as described in 4.4.3.
- It is recommended to limit the maximum length of the RS-485 daisy chain to a maximum length of 3000 feet (914 m). Additionally, no individual run should be longer than 300 ft. (91.4m).
- Possible to connect and mix different models under same ENC card depending on model and firmware version (contact technical support team)

When the inverters are monitored via the RS-485 communication, a unique RS-485 address for each inverter can be set up through LCD interface. The Inverter Modbus IDs are configurable from 1 to 128. The daisy-chain topology is recommended for the RS-485 network connection to minimize noise and bus reflections, as shown in Figure 4-41 RS-485 Network Connection. Other communication topologies, such as the star networks, are not recommended.

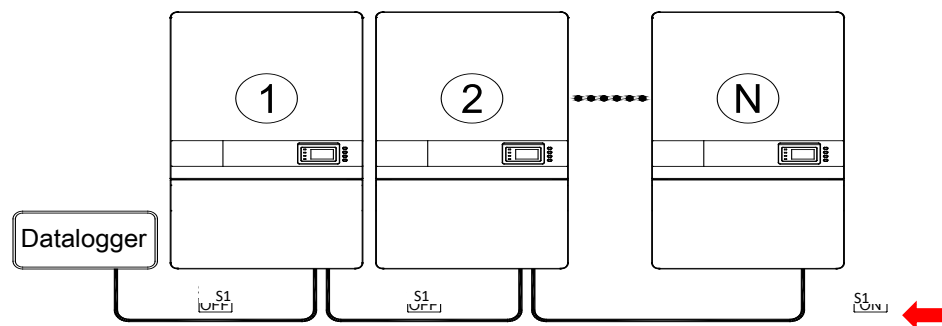

Figure 4-41 RS-485 Network Connection

If there are multiple inverters in the RS-485 network, the selector switch S1 of the last inverter in the daisy-chain should be in ON position, to have the 120Ω terminal resistor enabled. The selector switch S1 of all other inverters should be in the OFF position to disable the terminal resistor.

4.4.6 Third-Party Data Acquisition System (DAS) Connection

NOTICE!

Ethernet Only Connection: The PVI 25TL-208, PVI-36TL-480-V2, PVI 50TL-480, AND PVI 60TL-480 inverter only supports RS485 connections to a 3rd party DAS.

4.5 Communication Wiring

1. Open the inverter wiring box. Refer to Section 4.3.1 for instructions and torque requirements when replacing cover.
2. Bring the communication cables into the wiring box through the provided knockout holes at the bottom, using similar methods to the AC and DC wiring. Conduit and knockouts must be sealed and water tight to maintain the NEMA 4X rating.
3. Connect the RS485 wires to the P7 connector (network P7 and P9) ensuring correct polarity and using a shielded twisted pair cable.
4. If the inverter is the last Modbus device in the daisy chain and the inverter without the Ethernet Network Card, make sure the Modbus termination switch S1 is in the ON position, enabling Modbus

termination. Ensure the switch is in the OFF position for all other inverters in the daisy chain, including the one where the Ethernet Network Card is installed.

5. The shield of the individual cables must be open (not connected to ground) on one end – the other end of the shield must be grounded.

WARNING

Risk of Electric Shock: Make sure all shield wires are properly secured and insulated to prevent shorting to any other components inside the inverter. Failure to follow this installation practice will increase lightning surge damage to the inverter and will void the warranty.

6. Close the wiring box.
7. Reconnect the AC and DC power and turn the inverter on when it is safe.
8. Configure the Inverter Modbus ID and Baud rate.

5. User Interface

This section is intended to orient the user with the inverter interface prior to turning the system on and commissioning.

5.1 Description of the Interface

The inverter's user interface screen mainly consists of the LCD screen, four LED status indicator lights, a buzzer, and four user keys, as shown in Figure 5-1.

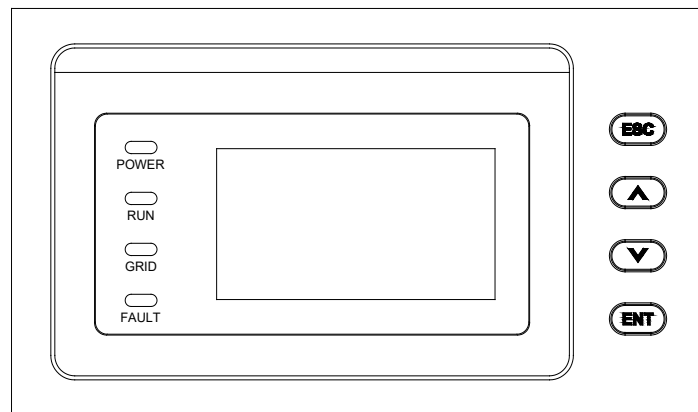

Figure 5-1 User Interface

The LCD panel includes a screen-saver function to increase the service life of the display. If there is no user activity or operation (key press) for greater than 1 minute, the display will enter the screen-saving mode to protect the screen and prolong the service life.





During normal inverter operation, a key press or any warnings or system faults that may occur will cause the LCD to exit screen-saver mode.

Interpretation for the indicator lights is shown in Table 5-1 and function of the keys is shown in Table 5-2.

Table 5-1 LED Indication Meaning

LED LIGHT	DESCRIPTION
POWER	Working Power Indicator Light
	On: DC Power is available (control panel works)
	Off: DC Power not available
RUN	Grid-Tied Operation Indicator Light
	On: In grid-tied power generation state
	Flash: Running but derated (light on 0.5s, light off 1.6s)
	Off: In other operation status or power supply not working
GRID	Grid Status Indicator Light
	On: Grid normal
	Flash: Grid fault (on 0.5 seconds, off 1.6 seconds)
	Off: Power supply is not working
FAULT	Fault Status Indicator Light
	On: Fault has occurred
	Fast Flash: Protective Action (on 0.5 seconds, off 0.5 seconds)
	Slow Flash: Warn / Alarm (on 0.5 seconds, off 2 seconds)
	Off: No detected fault or power supply is not working

Table 5-2 Definition of the Keys

KEY	DESCRIPTION	DEFINITION OF FUNCTION
	Escape key	Back/end/mute
	Enter key	Confirm entering the menu/confirm set value/Switch to parameter setting mode
	Up	Page up in selection menu/+1 when setting parameters.
	Down	Page down in selection menu/-1 when setting parameters

5.2 Operation State

- “**POWER**” will light up to indicate that the system is energized and under DSP control.
- “**RUN**” will light up when the inverter detects that the grid connection conditions meet the requirements; and power is fed into the grid. “**RUN**” will blink if the grid is in de-rated running state during the period of feeding power into the grid. Derate may be caused by low grid voltage, voltage being outside of the MPPT voltage range window, or excessive temperature.
- “**GRID**” will light up when the grid is normal during the operation of the inverter. Otherwise, “**GRID**” will blink until the grid restores to normal.
- “**FAULT**” will blink quickly when a fault (except grid fault) occurs. “**FAULT**” will stay illuminated until the fault is eliminated. The LED will blink slowly when an alarm occurs. “**FAULT**” remains illuminated when an internal fault occurs.

5.3 Interface Types

Users can perform the corresponding operations with the 4 function keys according to the indications of the LCD.

The LCD screen will display different interfaces based on the operation modes of the inverter. There are four operation modes: **Logo/Start-up** interface, **Normal operation**, **Standby**, and **Fault** mode.

- (1) **Logo/Start-up** mode displays the Yaskawa Solectria Solar logo when the inverter is checking if conditions are met for connection after a manual start-up of the inverter.
- (2) **Normal Operation** mode is the default indication interface for normal operation. In this mode, the inverter is converting the DC power from the array to AC power, feeding it continuously to the grid.
- (3) **Standby** mode is active when the output voltage and power of PV modules do not meet the startup conditions or PV voltage and input power are lower than the set value. The inverter will check automatically whether it meets the startup conditions in this mode until it turns back to Normal Operation mode.
- (4) **Fault** mode is displayed when the inverter disconnects from the grid due to a fault in the inverter or grid. Check the Fault log under **Current Errors** and reference the “Troubleshooting” table in section 8 to

(1) The LCD interface starts with the company logo once the system is energized, as shown in Figure 5-2.



Figure 5-2 Logo Screen

(2) Indication of inverter operation mode:

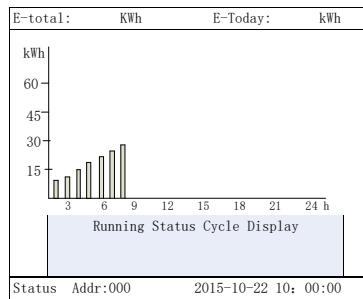

Figure 5-3 Default Display Interface for Normal Operation

History		
Num	Time&Date	Error Code
001	2015/10/22 12:20:08	W0130
002	2015/10/22 12:30:11	P0020
003	2015/10/22 13:20:08	F0140
004	2015/10/24 10:20:04	.
005	2015/10/24 09:31:08	.
006	2015/10/25 12:20:08	F0150
007	2015/10/25 16:11:18	W0130
008	2015/10/25 17:21:07	F0070
		P0360
		P0050
		P1/1

Figure 5-4 Fault Indication Interface

While the inverter is in **Normal Operation** mode (and not in screen saver) the interface indicates PV voltage, PV current, grid voltage, instant power, daily generated power and time. This is the “Default Indication Interface.”

(3) Indication of standby mode:

The inverter will enter Standby mode when the output voltage and power of PV modules do not meet the startup conditions or PV voltage and input power are lower than the set value. The inverter will check automatically whether it meets the startup conditions in this mode until it turns back to normal mode. The inverter will switch from standby mode to fault mode if a malfunction occurs.

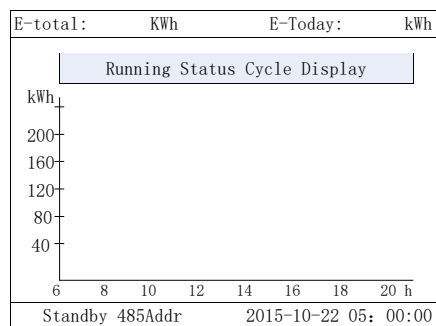

Figure 5-5 Standby mode

- (4) If the inverter experiences a Fault it will enter Fault mode and display the current or most recent faults.

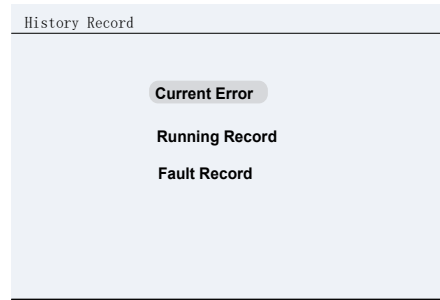

Figure 5-6 History Record Interface

The inverter will disconnect from the power grid and turn into fault mode when the inverter or power grid fails. Check the specific cause in “Troubleshooting Table” (Section 8) according to the fault message displayed on the LCD and eliminate the fault referred to in the instructions. The fault information of the most recent / currently present fault will be shown on the LCD when the inverter is in fault mode.

6. Commissioning

Before powering up the PV system it is important to check the installation for any hazards that may be present.

6.1 Commissioning Checklist

WARNING

Follow the Checklist: For your safety, please follow the guidelines below during the startup of your inverters.

6.1.1 Mechanical Installation

- Ensure that the mounting bracket is secure and all the screws have been tightened to the specified torque values. (Please refer to Section 4.2.5.1)
- Confirm all knockouts are sealed and conduits are securely attached to the inverter creating a water-tight seal.
- Confirm that all conduit entries into the inverter have been sealed with duct sealant to prevent condensation from entering into the Wiring Box.

6.1.2 Electrical Connections

- Make sure all conductors are landed on the correct terminals and properly labeled.
- Ensure that no sharp edges from cable ties exist. Appropriate cable management is the key to avoiding physical damage.
- Make sure all connections are tightened to torque specifications as per Section 4.3 Electrical Installation.
- The polarity of DC input cables should be correct and the DC Switch should be in the “OFF” position.

6.1.3 Electrical Check

- Make sure the AC circuit breaker is appropriately sized.
- Test the AC voltage and confirm that it is within the normal operating range.
- Test the polarity of DC inputs and confirm they are proper.
- Make sure the open circuit voltage of input strings is less than 1000VDC. Confirm the DC open circuit voltage of input strings is less than 1000V.

INFO ✓

If APsmart RSD-S-PLC-A products are installed and in the OFF position, each module will measure 0.6Vdc. Ensure the DC open circuit voltage of input strings will be less than 1000V when power is supplied to the Rapid Shutdown transmitter, if applicable.

6.2 Commissioning Steps

! WARNING

Electrical Shock Hazard

Installer may come into contact with components that have hazardous voltage and energy potential. Use proper safety equipment when energizing the inverter.

Follow these instructions when turning on an inverter.

- Turn ON the site AC breaker for the inverter.
- Complete the connection of the input PV source circuits (close the fuse holders).
- Turn ON the DC switch(s)/circuit breaker(s) on the inverter. When the energy supplied by the PV array is sufficient, the Power LED of the inverter will light up. The inverter will then start up with the message “sys checking”.
- You may change the grid standard. The default setting is IEEE 1547.
 - a. When the inverter completes “sys checking”, the LCD shows the screen as Figure 6-1 below. Press ENTER to the standard selection interface, as shown in Figure 6-1.



Figure 6-1 System Initialization Logo

- b. Setting Language. Press ENT to access the **MAIN MENU**, select Setting and press ENT. The password is “1111”, using the arrow keys enter the password and press ENT to access the next submenu. Select System Parameters, press ENT. Scroll to Setting Language, press ENT. Then select the desired language and press ENT.

- c. The default grid standard is IEEE 1547. If a different standard is needed please go to “Menu Functions” section for further instructions on how to change it. Available grid standards are shown in Figure 6-2.

INFO ✓

Please check with your local electricity provider before selecting the grid standard. If the inverter is operated with a wrong grid standard, the electricity provider may cancel the interconnection agreement. Putting the inverter into operation before the overall system complies with the national rules and safety regulation of the application is not permitted.

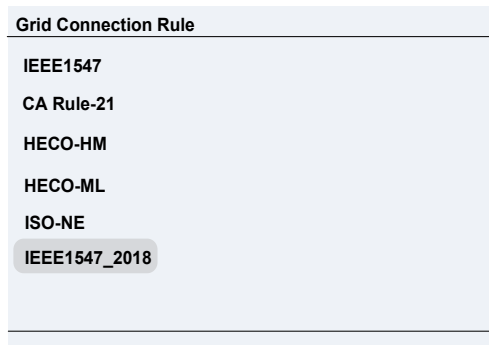

Figure 6-2- Select Grid Standard; ML-Molokai/Lanai; OHM- Oahu, Maui, and Hawaii

- Setting the Time. From the previous menu, press **ESC** to return to the System Parameters menu. Select Time and press **ENT**. Scroll up/down to select the numerical value, then press **ENT** to go to next option. e.g.: Year to Month, press **ESC** to go to last option. e.g.: Month to Year. Finally Press the **ENT** key to confirm the setting. (Press the “up” arrow more than 1 second to go to last position of the number when setting the parameters. e.g: 2008 to 2008. Press the “down” arrow more than 1 second to go to the next position of the number when setting the parameters. e.g: 2008 to 2008.)
- The factory default working mode of the DC input connection and MPP Tracker is set for Independent and shall only be configured as Independent. Parallel is not an option for this inverter line.
- Neutral Line Setting. From the previous menu, press **ESC** to return to the System Parameters menu. Select Neutral Line Setting and press **ENT**. Use the arrow keys to highlight “Yes” or “No” in regard to whether a neutral conductor is present. Press **ENT**. This setting will allow the inverter to display L-N voltages on the LCD. It will not affect the operation of the inverter.

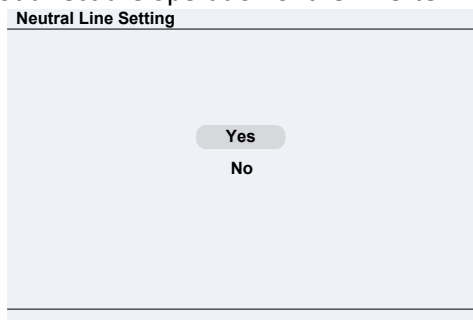

Figure 6-3 Setting the Neutral Line

Choosing the communication data. From the previous menu, press **ESC** to return to the System Parameters menu. Scroll to Communication Setting and press **ENT**. Select Baud rate and press **ENT**. The default setting is 9600. Depending on the data acquisition/SCADA system being used, the baud rate may need to be increased or decreased. Scroll up/down to select other speeds and press **ENT**.

Next, select Address and press **ENT**. This designates the inverter address. Each inverter within the Modbus network must have a unique address (Unit ID). Scroll up/down to choose an address for the inverter and press **ENT**. Addresses can be assigned from 1-128. See Figure 6-4.

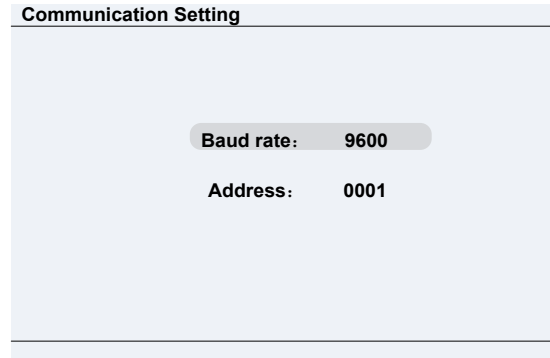

Figure 6-4 Communication Setting

- Setting the LCD contrast grade. From the previous menu, press **ESC** to return to System Parameters menu. Select LCD Contrast Setting and press **ENT**. Using the up/down arrows increase or decrease the contrast to the desired setting. Press **ENT** to accept the changes.
- When the LCD screen shows the normal operation status Figure 6-5 and the "RUN" light on the LED panel is illuminated, this is an indication that the grid connection and power generation were successful.

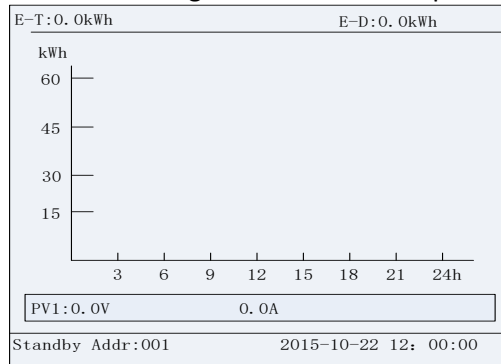

Figure 6-5 Normal Operation Status

INFO ✓

The Running status cycle display include: NoErr (Error information), Pdc(kW), Udc(V), Idc(A), Pac(kW) and Q(kvar).

- If the inverter fails to operate normally, the “FAULT” light will illuminate and the fault menu will be displayed. Select Current Error and press **ENT** to access the current faults the inverter has recorded. This information will show on the LCD screen as shown in the Figure 6-6.

Current Error		
Date	Time	Fault
2015/10/22	12:20:08	ArcboardErr
2015/10/22	12:20:08	Fault0040
2015/10/22	12:20:08	Fault0040
2015/10/22	12:20:08	Fault0040
2015/10/22	12:20:08	Fault0040

P1/1

Figure 6-6 Fault Information Interface

7. Menu Functions

LCD displays “Main user interface” when the inverter is in operation mode. Press **ESC** in this interface to escape the default interface and to enter the main operation interface. The main operation interface is shown in Figure 7-1.

Main Menu
Measurement Data Setting Power On/Off History Record Device Information

Figure 7-1 Main Menus on the LCD

The main operation interface of LCD screen has 5 menus, i.e. **MEASUREMENT DATA**, **SETTINGS**, **POWER ON/OFF**, **HISTORY RECORD**, and **DEVICE INFORMATION**. The users may select options with **▲** and **▼**, and then press **ENT** to confirm selection. The users can return to the default indication interface by pressing **ESC** key.

7.1.1 MEASUREMENT DATA

When the cursor moves to **MEASUREMENT DATA** in the main screen, you should press **ENT** to select the operation information as shown in Figure 7-2 . Check the information by pressing **UP** and **DOWN**. Return to the previous menu by pressing **ESC**.

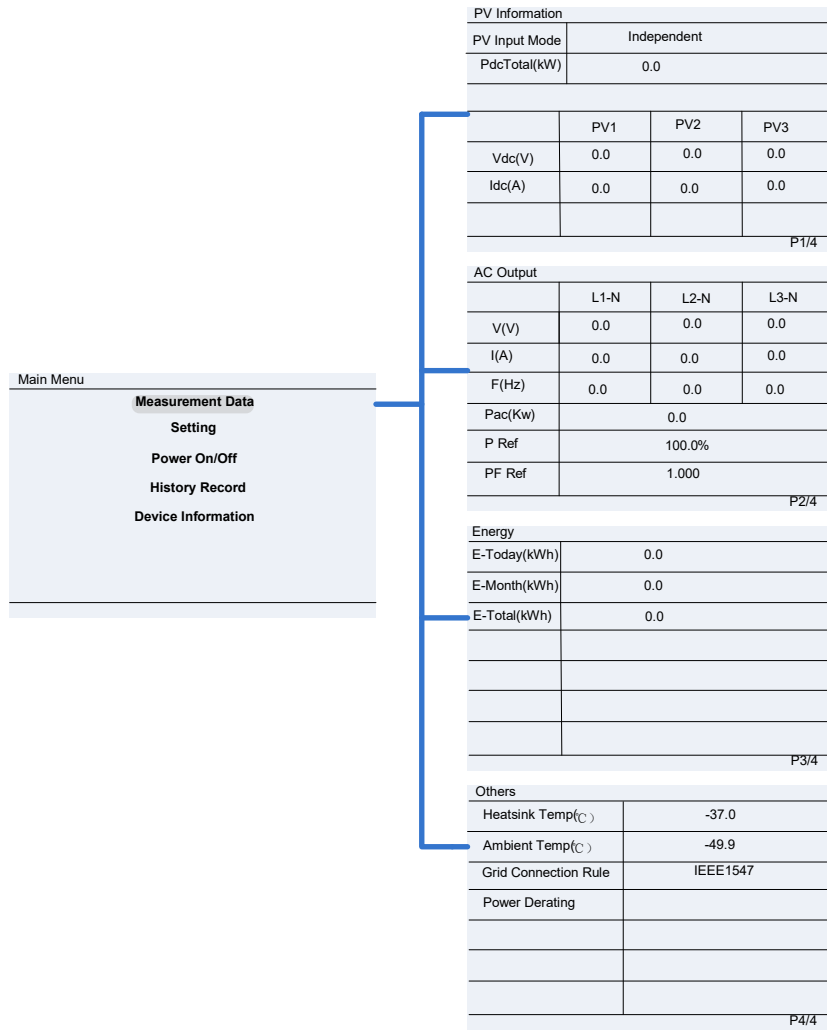

Figure 7-2 MEASUREMENT DATA

7.1.2 Setting

Move the cursor to **SETTINGS** in the main interface. Press **ENT**, you will be asked for a password. Enter the password: “0000” as shown Figure 7-3. Change the password digits by pressing **▲** and **▼**. Then press **ENT** to input the next digit and Press **ENT** to confirm the password or Press **ESC** return back to setting.

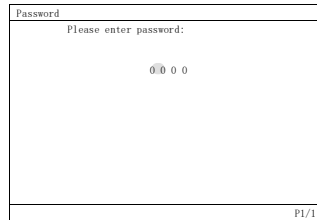

Figure 7-3 Password Screen for Settings Menu

Press **ENT** to confirm, and set the current system parameters, as shown in Figure 7-4. There are 8 submenus in Parameters Setting: **SYSTEM PARAMETERS**, **CONTROL COMMAND**, **PROTECTION PARAMETERS**, **L/HVRT PARAMETERS**, **ACTIVE DERATING SETTING**, **REACTIVE DERATING SETTING**, **ARC PARAMETERS**, and **OTHER PARAMETERS**.

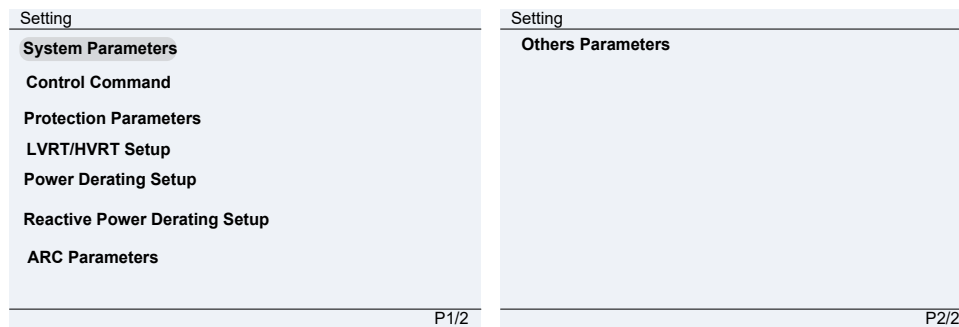

Figure 7-4 System Settings Menu

7.1.2.1 System Parameters

The System Parameter selection contains seven submenus.

- (1) **LANGUAGE SETTING:** Two languages, i.e. English and Chinese is available in **LANGUAGE** menu.
- (2) **GRID CONNECTION RULE:** There are multiple grid standards. Press **▲** and **▼** to select the corresponding grid standard required for the installation and press the **ENT** key to confirm the selection as shown in Figure 7-5.

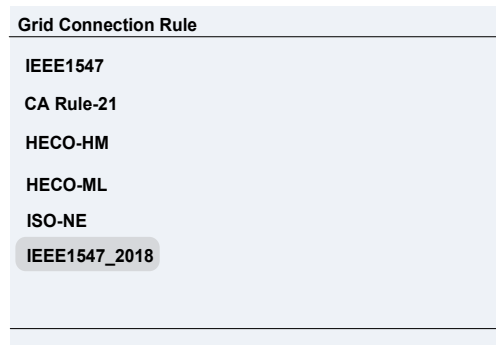



Figure 7-5 GRID CONNECTION RULE

INFO ✓

Please check with your local electricity supply company before selecting the grid standard. If the inverter is operated with a wrong grid standard, the electricity supply company may cancel the operation license. Putting the inverter into operation before the overall system complies with the national rules and safety regulation of the application is not permitted.

- (3) **PV INPUT MODE:** The inverter can work only under “Independent Mode”
- (4) **NEUTRAL LINE SETTING:** Select Yes or No if a neutral conductor has been connected to the inverter. This setting does not affect the operation of the inverter. When a neutral is installed and “Yes” is selected, the inverter will display L-N measurements.
- (5) **COM SETTING:** In this interface you can set the address and baud rate for communication.
- (6) **TIME:** Press “

7.1.2.2 Control Command

There are 5 submenus in the **CONTROL COMMAND**:

- (1) **FORCE RESTART** menu: If a fault shutdown happens, a severe fault may have occurred inside the inverter. The user can perform a manual/forced reboot once using this menu if the user needs to restart the inverter.

Control Command	Control Command		
Force Restart	PV1	PV2	PV3
Factory Defaults	Time		
ARC Detect	Vmppt(V)	0	0
ARC Clear	Pmppt(kW)	0.0	0.0
	Udc(V)	0.0	0.0
	Idc(A)	0.0	0.0
P1/2	MPPT Scan		P2/2

Figure 7-6 Control Command Setting

INFO ✓

FORCE RESTART is effective only when the faults “IntFault0010~0150” in the troubleshooting table occur. The inverter may restore to normal operation automatically if alarm or protection faults occur. This function will not respond when the inverter is in operation mode and a “FaultOperated” alarm will be indicated on the LCD.

- (2) **FACTORY DEFAULT** menu: The manufacturer’s default parameters value can be restored when the inverter is not in operation mode. If you try to change the parameters while the unit is operational. Otherwise “Fault Operated” will be displayed.
- (3) **ARC DETECT** In the **PARAMETERS SETTING** → **CONTROL COMMAND** menu, will execute “ARC Detect”. The inverter will cease power production and test ARC.

Arcing check and protection is mainly divided into two parts: the arcing check board is responsible for detecting if there is arcing in the PV line, and sends the arcing protection signal to the DSP in the control board. The control board “DSP” is responsible for disconnecting the inverter from the grid after receiving the arcing signal to ensure safety. The arcing board failure will cause ‘arc board err’ shown on the LCD and it will not connect to the grid until the arc board is OK. If there is Arcing fault, the LCD displays the fault which can only be cleared manually.

- (4) **ARC CLEAR** is used to clear the ARC fault. Move the cursor to this menu, and press ENT. The operation result will appear on the LCD, ie. “Succeed” or “Failed”. Complete this action after checking the PV system for potential arcs and taking corrective action.
- (5) **MPPT SCAN** menu: is to execute the MPPT scanning manually. Move the cursor to this item, and press **ENT** to initiate the scanning. The LCD screen will skip to normal operation interface if the MPPT scanning succeeds, or remain on the **MPPTSCAN** menu interface if the scanning fails.

MPPT scan function is used for multi-MPP tracking, if the PV panels are partly shadowed or installed with different angle. The factory default setting of MPPT scan is “Enabled”, and it can also be Disabled. When the MPPT scan function is enabled, the scan period is 60 minutes; the inverter will scan the maximum power point in the MPPT range, according to below condition:

In independent mode (3 MPPTs), each input power must be lower than 75% of the rated power of each MPPT tracker.

Once this MPPT scan function is activated thru the LCD, it will search the maximum power point at a voltage step of 5V in the MPPT range for full load, and get the maximum power point.

7.1.2.3 Protect Parameters

In this interface you can change the Protect parameters of grid voltage, frequency and recovery, etc., as shown in Figure 7-7. You can't enable/disable the function. The protect parameters are shown in Table 7-1.

Setting System Parameters Control Command Protection Parameters LVRT/HVRT Setup Power Derating Setup Reactive Power Derating Setup ARC Parameters	Grid Over Voltage Protection			Grid Under Voltage Protection		
	GridVolMax1	110.00%	Enable	GridVolMin1	88.00%	Enable
	VolMaxTripT1(S)	13.00		VolMinTripT1(S)	21.00	Enable
	GridVolMax2	120.00%	Enable	GridVolMin2	50.00%	Enable
	VolMaxTripT2(S)	0.16		VolMinTripT2(S)	2.00	Enable
	GridVolMax3	120.00%	Disable	GridVolMin3	50.00%	Disable
	VolMaxTripT3(S)	0.16		VolMinTripT3(S)	2	Disable
	P1/7			P2/7		
	Grid Over Frequency Protection			Grid Under Frequency Protection		
	GridFrqMax1(Hz)	61.20	Enable	GridFrqMin1(Hz)	58.50	Enable
	FrqMaxTripT1(S)	300.00		FrqMinTripT1(S)	300.00	Enable
	GridFrqMax2(Hz)	62.00	Enable	GridFrqMin2(Hz)	56.50	Enable
	GridMaxTripT2(S)	0.16		GridMinTripT2(S)	0.16	Disable
	GridFrqMax3(Hz)	62.00	Disable	GridFrqMin3(Hz)	56.50	Disable
	FrqMaxTripT3(S)	0.16		FrqMinTripT3(S)	0.16	Disable
P3/7			P4/7			
Grid Recovery			Voltage Moving Average			
VolMax	105.00%		VolMax	110.00%	Disable	
VolMin	91.70%		MaxTripT(S)	600.00	Disable	
VolRecoveryT(S)	300.00		VolMin	88.00%	Disable	
FrqMax(Hz)	60.10		MinTripT(S)	600.00		
FrqMin(Hz)	59.50					
FrqRecoveryT(S)	300.00					
P5/7			P6/7			
Grid Voltage Balance						
GridVolUnbalance	10.00%	Enable				
PhaseLoseCoeff	3.0%					
PhaseLoseRcvCoeff	2.0%	Disable				
PhaseLoseVUnbalance	10.00%					
Phase-PETripVolt	45.00%	Disable				
Phase-PERcvVolt	35.00%					
P7/7						

Figure 7-7 Protection Parameters Setting

INFO ✓

There are 7 pages of parameters displayed. Switching between parameters is done by pressing **▲** and **▼**. Then press **ENT** to select it, change the parameter value by pressing **▲** and **▼** then press **ENT** to send the parameter to inverter. The LCD will display new parameters if the setting is successful. Otherwise the old parameters will display on the LCD.

Table 7-1 Protection Submenu Parameters with lower limit, default, and upper limit settings (IEEE 1547-2018 and Rule 21) for the PVI-36TL-480-V2 & PVI 50/60TL-480 and PVI 25TL-208

GRID VOLTAGE PROTECTION		SETTING RANGE								
PARAMETER NAME	DESCRIPTION	IEEE 1547-2018			RULE 21			ISO-NE		
		MIN	DEF	MAX	MIN	DEF	MAX	MIN	DEF	MAX
GRIDVOLTMAX1(%)	Level 1 Max. grid voltage	100.00	110.00	135.00	100.00	110.00	135.00	100.00	110.00	135.00
VOLTMAXTRIP TIME1(S)	Level 1 Max. grid trip voltage	0.00	13.00	655.00	0.00	12.50	655.00	0.00	2	655.00
GRIDVOLTMAX2(%)	Level 2 Max. grid voltage	100.00	120.00	135.00	100.00	120.00	135.00	100.00	120.00	135.00
VOLTMAXTRIP TIME2(S)	Level 2 Max. grid trip voltage	0.00	0.16	655.00	0.00	0.16	655.00	0.00	0.16	655.00
GRIDVOLTMAX3(%)	Level 3 Max. grid voltage	100.00	120.00	135.00	100.00	120.00	135.00	100.00	120.00	135.00
VOLTMAXTRIP TIME3(S)	Level 3 Max. grid trip voltage	0.00	0.16	655.00	0.00	0.16	655.00	0.00	0.16	655.00
GRIDVOLTMIN1 (%)	Level 1 Min. Grid voltage	0.00	88.00	100.00	0.00	88.00	100.00	0.00	88.00	100.00
VOLTMINTRIP TIME1(S)	Level 1 Min. grid trip voltage	0.00	21.00	655.00	0.00	20.50	655.00	0.00	2.00	655.00
GRIDVOLTMIN2 (%)	Level 2 Min. Grid voltage	0.00	50.00	100.00	0.00	70.00	100.00	0.00	50.00	100.00
VOLTMINTRIP TIME2(S)	Level 2 Min. grid trip voltage	0.00	2.00	655.00	0.00	10.50	655.00	0.00	1.1	655.00
GRIDVOLTMIN3(%)	Level 3 Min. Grid voltage	0.00	45.00	100.00	0.00	50.00	100.00	0.00	50.00	100.00
VOLTMINTRIP TIME3(S)	Level 3 Min. grid trip voltage	0.00	2.00	655.00	0.00	1.5	655.00	0.00	1.1	655.00

Table 7-2 Grid Frequency Protection

GRID FREQUENCY PROTECTION		SETTING RANGE								
		IEEE 1547-2018			RULE 21			ISO-NE		
PARAMETER NAME	DESCRIPTION	MIN	DEF	MAX	MIN	DEF	MAX	MIN	DEF	MAX
GRIDFRQMAX1(HZ)	Protection threshold value of Level 1 Max. grid frequency	60.00	61.20	66.00	60.00	60.50	66.00	60.00	61.20	66.00
FRQMAXTRIP1(S)	Trip time of Level 1 Max. grid frequency	0.00	300.00	1000.00	0.00	300.00	1000.00	0.00	300.00	1000.00
GRIDFRQMAX2(HZ)	Protection threshold value of Level 2 Max. grid frequency	60.00	62.00	65.00	60.00	62.00	66.00	60.00	62.00	66.00
FRQMAXTRIP2(S)	Trip time of Level 2 Max. grid frequency	0.00	0.16	1000.00	0.00	0.16	1000.00	0.00	0.16	1000.00
GRIDFRQMAX3(HZ)	Protection threshold value of Level 3 Max. grid frequency	60.00	62.00	66.00	60.00	62.00	66.00	60.00	62.00	66.00
FRQMAXTRIP3(S)	Trip time of Level 3 Max. grid frequency	0.00	0.16	1000.00	0.00	0.16	1000.00	0.00	0.16	1000.00
GRIDFRQMIN1(HZ)	Protection threshold value of Level 1 Min. grid frequency	48.00	56.50	60.00	48.00	56.50	60.00	48.00	56.50	60.00
FRQMINTRIP1 (S)	Trip time of Level 1 Min. grid frequency	0.00	300.00	1000.00	0.00	300.00	655.00	0.00	300.00	1000.00
GRIDFRQMIN2(HZ)	Protection threshold value of Level 2 Min. grid frequency	48.00	56.50	60.00	48.00	57.00	60.00	54.00	56.50	60.00
FRQMINTRIP2 (S)	Trip time of Level 2 Min. grid frequency	0.00	0.16	1000.00	0.00	0.16	655.00	0.00	0.16	1000.00
GRIDFRQMIN3(HZ)	Protection threshold value of Level 3 Min. grid frequency	48.00	56.50	60.00	48.00	57.00	60.00	54.00	56.50	60.00
FRQMINTRIP3 (S)	Trip time of Level 3 Min. grid frequency	0.00	0.16	1000.00	0.00	0.16	665.00	0.00	0.16	1000.00

Table 7-3 Grid Recovery

GRID RECOVERY		SETTING RANGE								
		IEEE 1547-2018			RULE 21			ISO-NE		
PARAMETER NAME	DESCRIPTION	MIN	DEF	MAX	MIN	DEF	MAX	MIN	DEF	MAX
VOLTMAX(%)	Recovery Max threshold of grid voltage protection	80.00	105.00	135.00	80.00	108.00	135.00	80.00	108.00	135.00
VOLTMIN (%)	Recovery Min threshold. grid voltage protection	20.00	91.70	100.00	20.00	90.00	100.00	20.00	90.00	100.00
VOLRECOVERYT(S)	Recovery time of grid voltage protection	0.00	300.00	655.00	0.00	300.00	655.00	0.00	300.00	655.00
FRQMAX (HZ)	Recovery Max threshold grid Frequency protection	54.00	60.10	66.00	54.00	60.40	66.00	54.00	61.00	66.00
FRQMIN (HZ)	Recovery Min threshold. grid Frequency protection	48.00	59.50	60.00	48.00	58.60	60.00	48.00	58.80	60.00
FRQRECOVERYT(S)	Recovery time of grid frequency protection	0.00	300.00	655.00	0.00	300.00	655.00	0.00	300.00	655.00

Table 7-4 Grid Voltage Moving Average

**GRID VOLTAGE
MOVING AVERAGE**

SETTING RANGE

PARAMETER NAME	DESCRIPTION	IEEE 1547-2018			RULE 21			ISO-NE		
		MIN	DEF	MAX	MIN	DEF	MAX	MIN	DEF	MAX
VOLTMAX(%)	The upper limit grid voltage of moving average filter	100.00	110.00	135.00	100.00	110.00	135.00	100.00	110.00	135.00
MAXTRIPT(S)	The trip time of the upper limit grid voltage of moving average filter	0.00	600.00	655.00	0.00	600.00	655.00	0.00	600.00	655.00
VOLTMIN(%)	The lower limit grid voltage of moving average filter	80.00	88.00	100.00	80.00	87.99	100.00	80.00	88.00	100.00
MINTRIPT(S)	The trip time of the lower limit grid voltage of moving average filter	0.00	600.00	655.00	0.00	600.00	655.00	0.00	600.00	655.00

Table 7-5 Grid Voltage Balance

Grid Voltage Balance		Setting Range								
		IEEE 1547-2018			RULE 21			ISO-NE		
PARAMETER NAME	DESCRIPTION	MIN	DEF	MAX	MIN	DEF	MAX	MIN	DEF	MAX
GRIDVOLBALANCE(%)	Unbalance rate of grid voltage	0.01	10.00	10.00	0.01	10.00	10.00	0.01	10.00	10.00
PHASELOSECOEFF(%)	Phase Loss Coefficient	0.5	3.0	30.0	0.5	3.0	30.0	0.5	3.0	30.0
PHASELOSERCVCOEFF(%)	Phase Loss Recovery Coefficient	0.5	2.0	30.0	0.5	2.0	30.0	0.5	2.0	30.0
PHASELOSEVUNBALANCE(%)	Phase Loss Voltage Unbalance	0.01	10.00	10.00	0.01	10.00	10.00	0.01	10.00	10.00
PHASE-PETRIPVOLT(%)	The trip voltage of Phase-PE	0.01	45.00	100.00	0.01	45.00	100.00	0.01	45.00	100.00
PHASE-PERCVVOLT(%)	The recovery voltage of Phase-PE	0.01	35.00	100.00	0.01	35.00	100.00	0.01	35.00	100.00

7.1.2.4 LVRT/HVRT

The **LVRT/HVRT** menus are used to set the LVRT and HVRT parameters. Move the cursor to this item and press the ENT key to set the parameters. There are 7 pages of LVRT/HVRT parameter settings. These can be changed in the menu tree or by the LVRT (Figure 7-9) and HVRT (Figure 7-10) graphs.

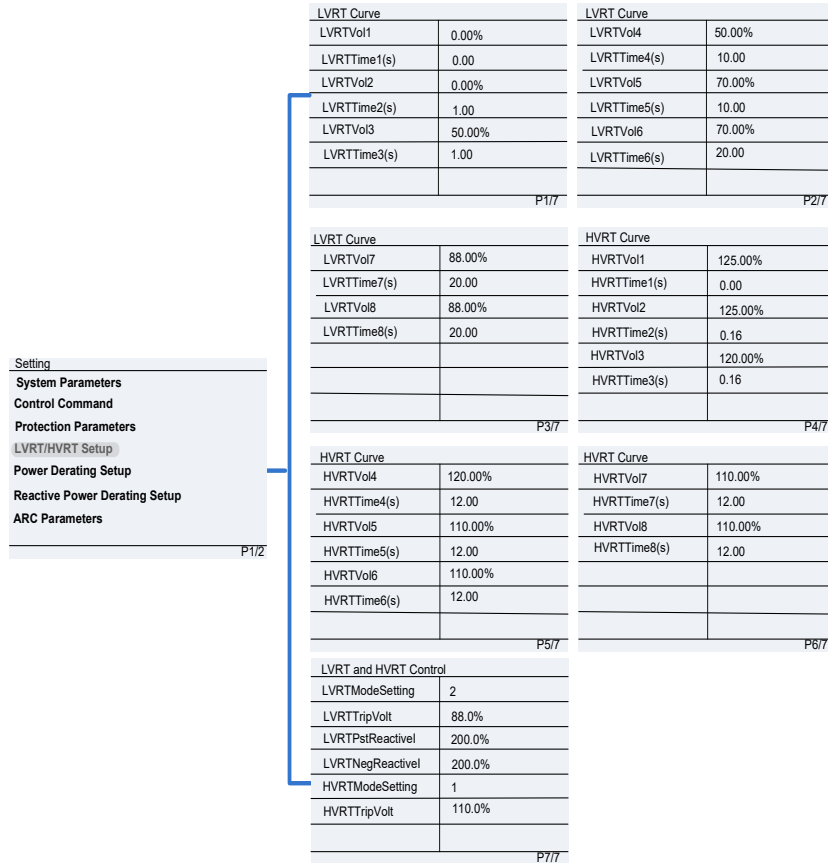

Figure 7-8 LVRT / HVRT Parameters

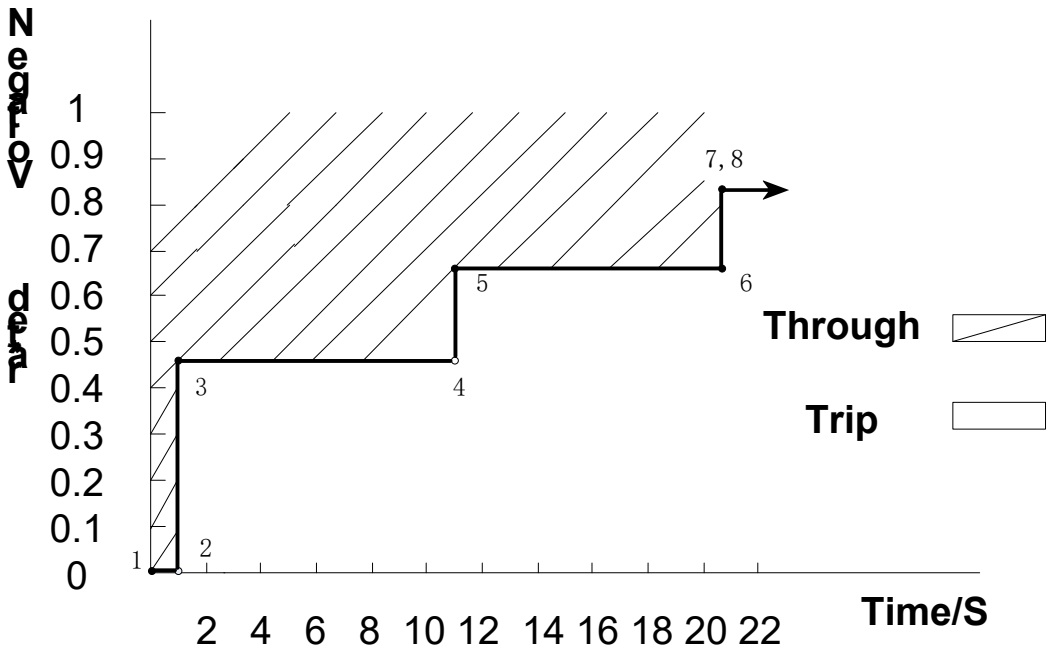

Figure 7-9 LVRT Curve

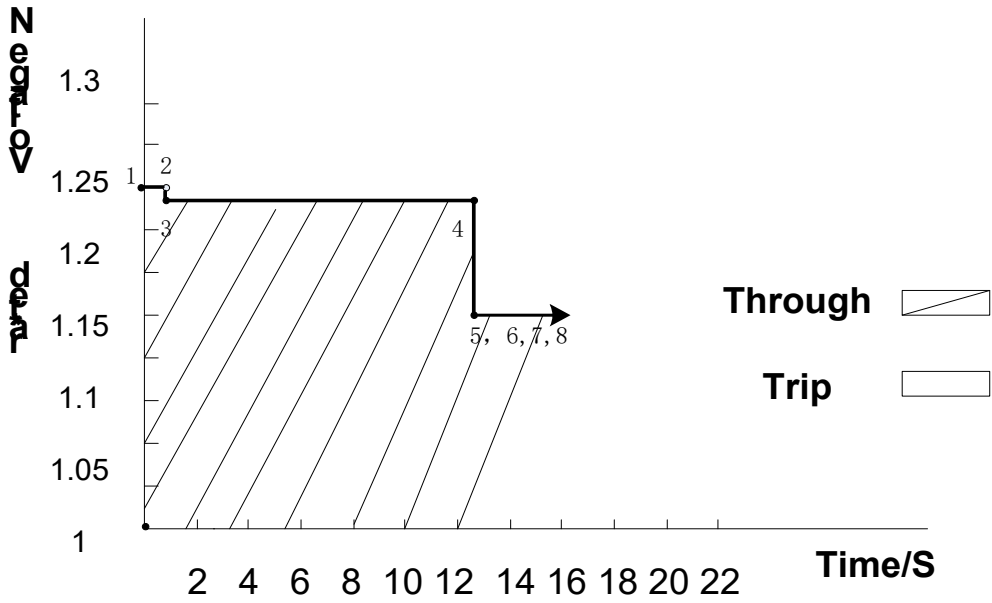

Figure 7-10 HVRT Curve

Table 7-6 LVRT Parameter List with Setup Lower Limit, Default, and Upper Limit

SETUP RANGE										
Parameter name	DESCRIPTION	IEEE 1547-2018			RULE 21			ISO-NE		
		MIN	DEF	MAX	MIN	DEF	MAX	MIN	DEF	MAX
LVRTVOLT (1,2) (%)	Threshold value of Low voltage ride through (1st & 2nd point)	0.00	0.00	100.00	0.00	0.00	100.00	0.00	0.00	100.00
		0.00	0.00	100.00	0.00	0.00	100.00	0.00	0.00	100.00
LVRTTIME (1,2) (S)	Time of Level Low voltage ride through (1st & 2nd point)	0.00	0.00	655.00	0.00	0.00	655.00	0.00	0.00	655.00
		0.00	1.00	655.00	0.00	1.20	655.00	0.00	0.16	655.00
LVRTVOLT (3,4) (%)	Threshold value of Low voltage ride through (3rd & 4th point)	0.00	50.00	100.00	0.00	50.00	100.00	0.00	30.00	100.00
		0.00	50.00	100.00	0.00	50.00	100.00	0.00	45.00	100.00
LVRTTIME (3,4) (S)	Time of Level Low voltage ride through (3rd & 4th point)	0.00	1.00	655.00	0.00	1.20	655.00	0.00	0.16	655.00
		0.00	10.00	655.00	0.00	10.50	655.00	0.00	0.21	655.00
LVRTVOLT (5,6) (%)	Threshold value of Low voltage ride through (5th & 6th point)	0.00	70.00	100.00	0.00	70.00	100.00	0.00	45.00	100.00
		0.00	70.00	100.00	0.00	70.00	100.00	0.00	65.00	100.00
LVRTTIME (5,6) (S)	Time of Level Low voltage ride through (5th & 6th point)	0.00	10.00	655.00	0.00	10.50	655.00	0.00	0.37	655.00
		0.00	20.00	655.00	0.00	20.50	655.00	0.00	0.37	655.00
LVRTVOLT (7,8) (%)	Threshold value of Low voltage ride through (7th & 8th point)	0.00	88.00	100.00	0.00	88.00	100.00	0.00	65.00	100.00
		0.00	88.00	100.00	0.00	88.00	100.00	0.00	88.00	100.00
LVRTTIME (7,8) (S)	Time of Level Low voltage ride through (7th & 8th point)	0.00	20.00	655.00	0.00	20.50	655.00	0.00	3.05	655.00
		0.00	20.00	655.00	0.00	20.50	655.00	0.00	3.25	655.00

Table 7-7 HVRT Parameters with Setup Range of Lower Limit, Default, and Upper Limit

Parameter name	DESCRIPTION	HVRT								
		IEEE 1547-2018			RULE 21			ISO-NE		
		MIN	DEF	MAX	MIN	DEF	MAX	MIN	DEF	MAX
HVRTVOLT (1,2) (%)	Threshold value of high voltage ride through (first or second point)	100.00	125.00	135.00	100.00	125.00	135.00	100.00	120.00	135.00
		100.00	125.00	135.00	100.00	125.00	135.00	100.00	120.00	135.00
HVRTTIME (1,2) (S)	Time of Level high voltage ride through (first or second point)	0.00	0.00	655.00	0.00	0.00	655.00	0.00	0.00	655.00
		0.00	0.16	655.00	0.00	0.11	655.00	0.00	0.16	655.00
HVRTVOLT (3,4) (%)	Threshold value of high voltage ride through (third or fourth point)	100.00	120.00	135.00	100.00	120.00	135.00	100.00	120.00	135.00
		100.00	120.00	135.00	100.00	120.00	135.00	100.00	117.50	135.00
HVRTTIME (3,4) (S)	Time of Level high voltage ride through (third or fourth point)	0.00	0.16	655.00	0.00	0.11	655.00	0.00	0.25	655.00
		0.00	12.00	655.00	0.00	12.50	655.00	0.00	0.25	655.00
HVRTVOLT (5,6) (%)	Threshold value of high voltage ride through (fifth or sixth point)	100.00	110.00	135.00	0.00	110.00	135.00	0.00	117.50	135.00
		100.00	110.00	135.00	0.00	110.00	135.00	0.00	115.00	135.00
HVRTTIME (5,6) (S)	Time of Level high voltage ride through (fifth or sixth point)	0.00	12.00	655.00	0.00	12.50	655.00	0.00	0.55	655.00
		0.00	12.00	655.00	0.00	12.50	655.00	0.00	0.55	655.00
HVRTVOLT (7,8) (%)	Threshold value of high voltage ride through (seventh or eighth point)	100.00	110.00	135.00	100.00	110.00	135.00	100.00	115.00	135.00
		100.00	110.00	135.00	100.00	110.00	135.00	100.00	110.00	135.00
HVRTTIME (7,8) (S)	Time of Level high voltage ride through (seventh or eighth point)	0.00	12.00	655.00	0.00	12.50	655.00	0.00	1.05	655.00
		0.00	12.00	655.00	0.00	12.50	655.00	0.00	1.05	655.00

Table 7-8 LVRT and HVRT Parameters (IEEE1547 and Rule 21)

LVRT/HVRT SETTINGS		SETTING RANGE								
		IEEE 1547-2018			RULE 21			ISO-NE		
PARAMETER NAME	DESCRIPTION	MIN	DEF	MAX	MIN	DEF	MAX	MIN	DEF	MAX
LVRTMODESETTING	0: Disable 1: Enable, no reactive power output 2: Enable, reactive power output	0	2	2	0	2	2	0	2	2
LVRTTRIPVOLT (%)	The trigger Voltage of LVRT	70.0	88.0	100.0	70.0	88.0	100.0	70.0	88.0	100.0
LVRTPSTREACTIVE 1	The coefficient of positive sequence reactive current	0	200.0	300.0	0.0	200.0	300.0	0.0	150.0	300.0
LVRTNEGREACTIVE 1	The coefficient of negative sequence reactive current	0	200.0	300.0	0.0	200.0	300.0	0.0	200.0	300.0
HVRTMODESETTING	0: Disable 1: Enable, no reactive power output 2: Enable, reactive power output	0	1	2	0	1	2	0	1	2
HVRTTRIPVOLT (%)	The trigger Voltage of HVRT	100.00	110.00	135.00	100.00	110.00	135.00	100.00	110.00	135.00

7.1.2.5 Power Derating Setup

The **POWER DERATING SETUP** menu is used to set the active power derating parameters including Active Power Derating, Over Frequency Derating, Low frequency derating, and High Temperature Frequency Derating, etc. The parameters are shown in Figure 7-11Error! Reference source not found..

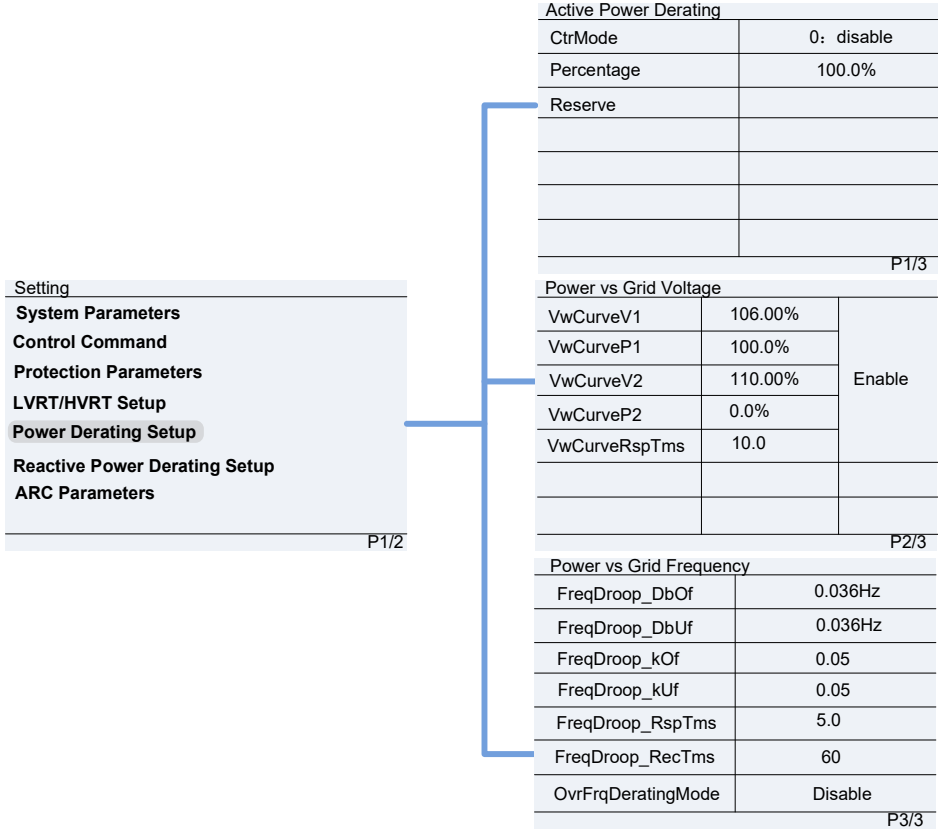

Figure 7-11 Power Derating Parameters

Power vs Grid Frequency: The active power output shall be as defined by the relevant formula below, plus any inertial response to the rate of change of frequency, until frequency returns to within the dead band.(See Figure 6-12)

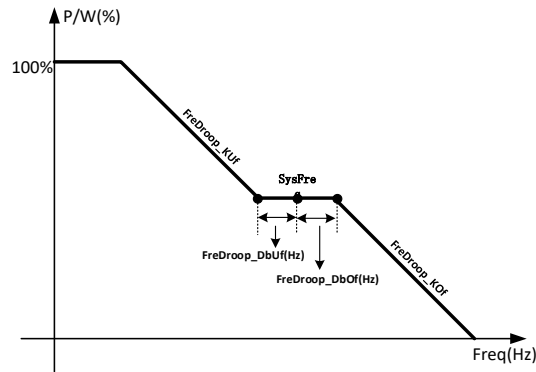

Figure 6-12 Curve of frequency derating

Formula for over frequency :

$$P = P_{pre} + (F_n + \text{FreqDroop_DbOf} - F_{pre}) / F_n / \text{FreqDroop_KOf}$$

Formula for under frequency:

$$P = P_{pre} + (F_n - \text{FreqDroop_DbUf} - F_{pre}) / F_n / \text{FreqDroop_KUF}$$

where

P is the active power output, in p.u. of the DER nameplate active power rating;

P_{pre} is the pre-disturbance active power output at the point of time, in p.u. of the DER nameplate active power rating;

F_n is the grid rated frequency

F_{pre} is the disturbed system frequency in Hz

Table 7-9 Active Power Derating Setup Ranges with Lower Limit, Default, and Upper Limit for IEEE 1547-2018 and CA Rule 21

SETTINGS RANGE

GRID OVER VOLTAGE DERATING

PARAMETER NAME	DESCRIPTION	IEEE 1547-2018			RULE 21			ISO-NE		
		MIN	DEF	MAX	MIN	DEF	MAX	MIN	DEF	MAX
VWCURVEV1 (%)	Grid overvoltage derating starting voltage V1	105.00	106.00	109.00	105.00	106.00	109.00	105.00	106.00	109.00
VWCURVEP1 (%)	Grid overvoltage derating starting power P1	0.00	100.00	100.00	0.00	100.00	100.00	0.00	100.00	100.00
VWCURVEV2 (%)	Grid overvoltage derating end voltage V2	106.00	110.00	110.00	106.00	110.00	110.00	106.00	110.00	110.00
VWCURVEP2 (%)	Grid overvoltage derating end power P2	0.0	0.0	100.0	0.0	0.0	100.0	0.0	0.0	100.0
VWCURVRSPTIME (S)	Open loop response time	0.5	10.0	90.0	0.5	5.00	90.0	0.5	10.0	90.0

GRID FREQUENCY DERATING										
FREQDROOP_DB UF(HZ)	The dead zone of over frequency active power regulation	0	0.036	1	0	0.036	1	0	0.5	1
FREQDROOP_KOF	The dead zone of under frequency active power regulation	0.02	0.05	0.1	0.02	0.05	0.1	0.02	0.05	0.1
FREQDROOP_KUF	Coefficient of under frequency active power regulation	0.02	0.05	0.1	0.02	0.05	0.1	0.02	0.05	0.1
FREQDROOP_RSP TMS (S)	Response time of frequency active regulation	0.2	5.00	10.00	0.2	5.00	10.00	0.2	5.00	10.00
FREQDROOP_RSC TMS (S)	Recovery time of frequency active regulation	0.00	60.00	1000.0	0.00	900.00	1000.0	0.00	900.00	1000.0
OVRFRQDERATIN GMODE	Overfrequency underload protection enable setting 0: Disable 1: Enable	0	0	1	0	1	1	0	0	1
CTRMODE	The control mode of active power 0: Disable dispatch 1: Remote dispatch 2: Local control	0	0	2	0	0	2	0	0	2
PERCENTAGE (%)	Local electric dispatch Active Power setting value	0.0	100.0	100.0	0.0	100.0	100.0	0.0	100.0	100.0

7.1.2.6 ReactivePowerDerating

The **REACTIVEPOWERDERATING** submenu is used to set the Grid reactive power derating parameters including PF parameters and Q parameters, etc. The parameters are shown in Table 7-10. Press **ENT** to start the modes after the parameters are set.

INFO ✓

The PF and Q value can be adjusted by remote software if the “Remote” is selected. Remote can be selected thru the Modbus map and the appropriate register.

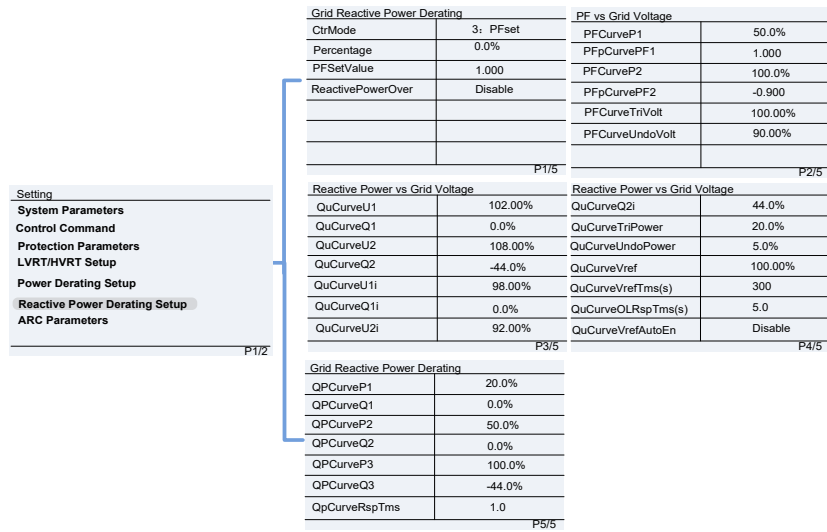

Figure 7-12 ReactivePowerDerating Parameter Screens PVI 25/36-V2/50/60TL-480

1. **PF Set:** Set the PF value. This function changes the reactive power by adjusting the Power Factor. **NOTE:** Change the reactive power by adjusting the PowerFactor.
2. **PF(P) Curve:** Use this mode to follow the default or user-specified PF curve. **NOTE:** The power factor changes according to the power change, as shown in Figure 7-13.

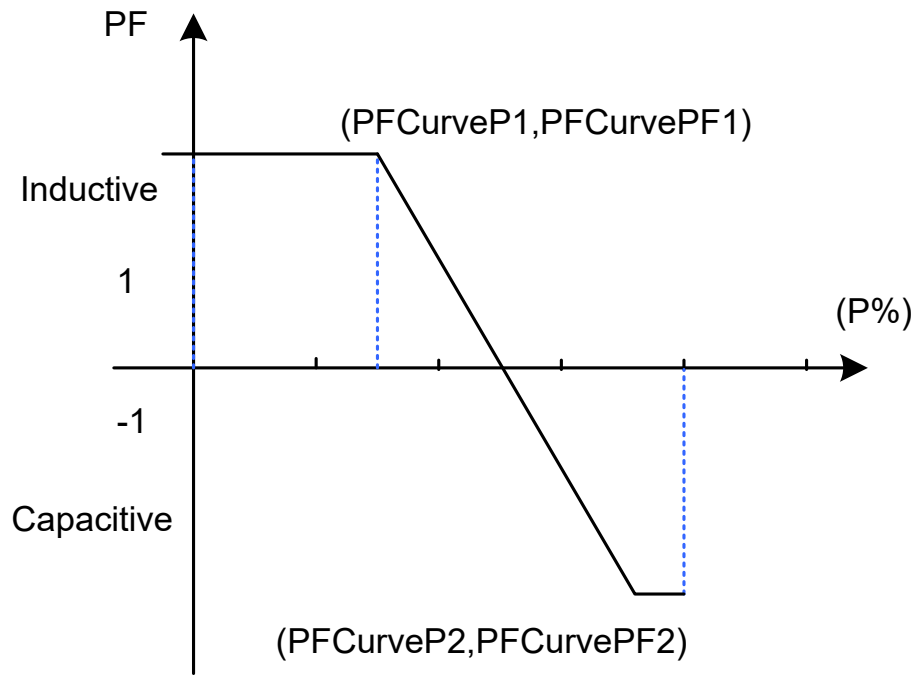

Figure 7-13 PF(P) Curve Mode Curve

Table 7-10 Reactive Power Derating Grid Parameters

PARAMETER NAME	DESCRIPTION	SETTING RANGE								
		IEEE 1547-2018			RULE 21			ISO-NE		
		MIN	DEF	MAX	MIN	DEF	MAX	MIN	DEF	MAX
PFPCURVEP1 (%)	Power of PF(P)Curve point 1	0.0	50.0	110.0	0.0	50.0	110.0	0.0	50.0	110.0
PF_PCURVEPF1	PF of PF(P)Curve point 1	-1.000 -0.800	1.000	0.800 1.000	-1.000 -0.800	1.000	0.800 1.000	-1.000 -0.800	1.000	0.800 1.000
PFPCURVEP2 (%)	Power of PF(P)Curve point 2	0.0	100.0	110.0	0.0	100.0	110.0	0.0	100.0	110.0
PF_PCURVEPF2	PF of PF(P)Curve point 2	-1.000 -0.800	-0.900	0.800 1.000	-1.000 -0.800	-0.900	0.800 1.000	-1.000 -0.800	-0.900	0.800 1.000
PFPCURVETRIVOLT (%)	The trigger voltage of PF(P)Curve	100.0	100.0	110.0	100.0	100.0	110.0	100.0	100.0	110.0
PFPCURVEUNDOVOLT (%)	The end voltage of PF(P)Curve	90.00	90.00	100.0	90.0	90.0	100.0	90.0	90.0	100.0

3. **Q(U) Curve:** Use this mode to follow the default or user-specified Q(U) curve.

NOTE: The reactive compensation changes according to the grid voltage, as shown in Figure 7-14.

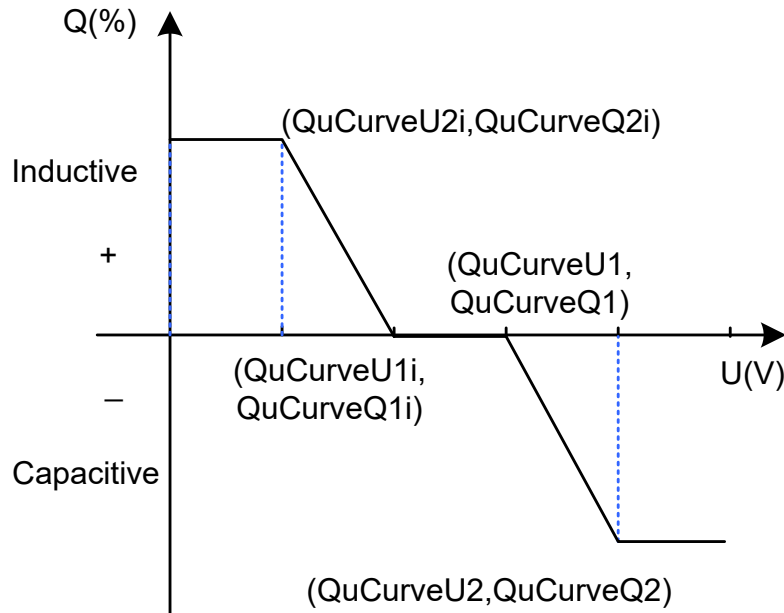

Figure 7-14 Q(U) Curve Mode Curve

INFO ✓

PF(P) Curve and Q(U) Curve Functions: These functions are only available for IEEE 1547 Grid Standards.

SETTING RANGE

Parameter name	Description	IEEE 1547-2018			RULE 21			ISO-NE		
		MIN	DEF	MAX	MIN	DEF	MAX	MIN	DEF	MAX
QUCURVEU1 (%)	Voltage of Q(U)Curve point 1	90.00	102.00	110.00	90.00	103.30	110.00	90.00	107.99	110.00
QUCURVEQ1 (%)	Reactive power of Q(U)Curve point 1	-60.0	0.0	60.0	-60.0	0.0	60.0	-60.0	0.0	60.0
QUCURVEU2 (%)	Voltage of Q(U)Curve point 2	90.00	108.00	120.00	90.00	107.00	120.00	90.00	110.00	120.00
QUCURVEQ2 (%)	Reactive power of Q(U)Curve point 2	-60.0	-44.0	60.0	-60.0	-30.0	60.0	-60.0	-50.0	60.0

QUCURVEU1I (%)	Voltage of Q(U)Curve point 1i	90.00	98.00	110.00	90.00	96.70	110.00	90.00	92.01	110.00
QUCURVEQ1I (%)	Reactive power of Q(U)Curve point 1i	-60.0	0.0	60.0	-60.0	0.0	60.0	-60.0	0.0	60.0
QUCURVEU2I (%)	Voltage of Q(U)Curve point 2i	80.00	92.00	110.00	80.00	92.00	110.00	80.00	90.00	110.00
QUCURVEQ2I (%)	Reactive power of Q(U)Curve point 2i	-60.0	44.0	60.0	-60.0	30.0	60.0	-60.0	50.0	60.0
QUCURVETRIPOWER (%)	The trigger power of Q(U)Curve	5.0	20.0	100.0	5.0	20.0	100.0	5.0	20.0	100.0
QUCURVEUNDOPOWER (%)	The end power of Q(U)Curve	5.0	5.0	100.0	5.0	5.0	100.0	5.0	5.0	100.0
QUCURVEVREF(%)	The rated reference voltage of Q(U) curve	300	300	5000	300	300	5000	300	300	5000
QUCURVEVREFTMS(S)	Open loop response time of Q(U) curve	1	5	90	1	5	90	1	5	90
QUCURVEVREFAUTOEN	The rated reference voltage enable of QU curve 0: Disable 1: Enable	0	0	1	0	0	1	0	0	1
CTRMODE	The control mode of reactive power 0: Disable dispatch mode 1: Remote dispatch mode 2: Local control, by Q 3: Local control, by PF 4: PF(P) curve 5: Q(U) curve 6: Q(P) curve	0	3	6	0	5	6	0	0	6
PERCENTAGE (%)	Local Power Factor Setting	-60.0	0.0	60.0	-60.0	0.0	60.0	-60.0	0.0	60.0
PFSETVALUE	Local Power Factor Setting	-1.000 -0.800	1.000	0.800 1.000	-1.000 -0.800	-0.950	0.800 1.000	-1.000 -0.800	1.00	0.800 1.000

4. **Q(P) Curve:** Q(P) curve mode. Using the curves to set the reactive power setpoints (See Figure 6-16). The reactive power compensation changes according to the active power.

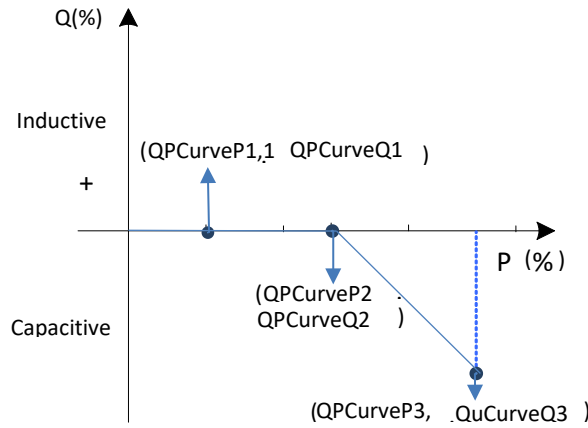

Figure 7-16 Q(P) Curve Mode Curve

SETTING RANGE

Parameter name	Description	IEEE 1547-2018			RULE 21			ISO-NE		
		MIN	DEF	MAX	MIN	DEF	MAX	MIN	DEF	MAX
QPCURVEP1 (%)	Active power of Q(P) Curve point 1	0.0	20.00	100.00	0.0	20.00	100.00	0.0	20.00	100.00
QPCURVEQ1 (%)	Reactive power of Q(P) Curve point 1	-66.0	0.0	66.0	-66.0	0.0	66.0	-66.0	0.0	66.0
QPCURVEP2 (%)	Active power of Q(P) Curve point 2	0.00	50.00	100.00	0.00	50.00	100.00	0.00	50.00	100.00
QPCURVEQ2 (%)	Reactive power of Q(P) Curve point 2	-66.0	0.0	66.0	-66.0	0.0	66.0	-66.0	0.0	66.0
QPCURVEP3 (%)	Active power of Q(P) Curve point 3	0.00	100.00	100.00	0.00	100.00	100.00	0.00	100.00	100.00
QPCURVEQ3 (%)	Reactive power of Q(P) Curve point 3	-66.0	-44.00	66.0	-66.0	-44.00	66.0	-66.0	-44.00	66.0
QPCURVERSPTMS(S)	Response time of Q(P)Curve	0.00	1.00	10.00	0.00	1.00	10.00	0.00	1.00	10.00

7.1.2.7 Arc Parameters

The **ARC PARAMETERS** submenu is used to enable/disable the ARC function and set the ARC parameters. These settings are only to be changed by Yaskawa Solectria Solar personnel with approval from the AHJ.

<table border="1"> <tr><td>Setting</td></tr> <tr><td>System Parameters</td></tr> <tr><td>Control Command</td></tr> <tr><td>Protection Parameters</td></tr> <tr><td>LVRT/HVRT Setup</td></tr> <tr><td>Power Derating Setup</td></tr> <tr><td>Reactive Power Derating Setup</td></tr> <tr style="background-color: #e0e0e0;"><td>ARC Parameters</td></tr> </table> <p style="text-align: right;">P1/2</p>	Setting	System Parameters	Control Command	Protection Parameters	LVRT/HVRT Setup	Power Derating Setup	Reactive Power Derating Setup	ARC Parameters	<table border="1"> <tr><td colspan="2">ARC Bandwith Setting</td></tr> <tr><td>ARCEnable</td><td>Disable</td></tr> <tr><td> </td><td> </td></tr> <tr><td> </td><td> </td></tr> <tr><td> </td><td> </td></tr> <tr><td> </td><td> </td></tr> <tr><td> </td><td> </td></tr> <tr><td> </td><td> </td></tr> <tr><td> </td><td> </td></tr> <tr><td> </td><td> </td></tr> </table> <p style="text-align: right;">P1/1</p>	ARC Bandwith Setting		ARCEnable	Disable																
Setting																													
System Parameters																													
Control Command																													
Protection Parameters																													
LVRT/HVRT Setup																													
Power Derating Setup																													
Reactive Power Derating Setup																													
ARC Parameters																													
ARC Bandwith Setting																													
ARCEnable	Disable																												

Figure 7-17 **ARC PARAMETERS** Submenu

7.1.2.8 Others Parameter

The **OTHER PARAMETERS** submenu is used to set additional parameters including MPPT scan period, nominal derating step and GFCI, DCI parameters. Press **ENT** and use **UP/DOWN** keys to set parameters and enable/disable the functions. Press **ENT** to confirm the setting. The parameters shown in Figure 7-15 and Table 7-11.

<table border="1"> <tr><td>Setting</td></tr> <tr style="background-color: #e0e0e0;"><td>Others Parameters</td></tr> </table>	Setting	Others Parameters	<table border="1"> <tr><td colspan="3">Others</td></tr> <tr><td>PowerOnDelay(s)</td><td>300</td><td></td></tr> <tr><td>ReactivePowerStep</td><td>25.00%</td><td></td></tr> <tr><td>eErrSoftStarTms</td><td>300</td><td></td></tr> <tr><td>eNormSoftStopTms</td><td>1</td><td>Enable</td></tr> <tr><td>eNormSoftStartTms</td><td>1</td><td></td></tr> <tr><td>NormalDeratingStep</td><td>100.00%</td><td></td></tr> </table> <p style="text-align: right;">P1/8</p>	Others			PowerOnDelay(s)	300		ReactivePowerStep	25.00%		eErrSoftStarTms	300		eNormSoftStopTms	1	Enable	eNormSoftStartTms	1		NormalDeratingStep	100.00%		<table border="1"> <tr><td colspan="3">Others</td></tr> <tr><td>PVSlowStartStep</td><td>10.00%</td><td>Disable</td></tr> <tr><td>PVSlowStartPwDelta</td><td>5.00%</td><td></td></tr> <tr><td>FaultPowerT(C)</td><td>95.0</td><td></td></tr> <tr><td>FaultEnvT(C)</td><td>83.0</td><td></td></tr> </table> <p style="text-align: right;">P2/8</p>	Others			PVSlowStartStep	10.00%	Disable	PVSlowStartPwDelta	5.00%		FaultPowerT(C)	95.0		FaultEnvT(C)	83.0		<table border="1"> <tr><td colspan="3">Others</td></tr> <tr><td>GFCIStaticValue(mA)</td><td>540</td><td></td></tr> <tr><td>GFCIStaticT(s)</td><td>0.2</td><td>Enable</td></tr> <tr><td>GFCIDynProFactor</td><td>100.0%</td><td>Enable</td></tr> <tr><td>DCIProtection1</td><td>0.50%</td><td>Enable</td></tr> <tr><td>DCIProtectionT1(s)</td><td>60.00</td><td></td></tr> <tr><td>DCIProtection2(mA)</td><td>950</td><td>Disable</td></tr> <tr><td>DCIProtectionT2(s)</td><td>1.00</td><td></td></tr> </table> <p style="text-align: right;">P3/8</p>	Others			GFCIStaticValue(mA)	540		GFCIStaticT(s)	0.2	Enable	GFCIDynProFactor	100.0%	Enable	DCIProtection1	0.50%	Enable	DCIProtectionT1(s)	60.00		DCIProtection2(mA)	950	Disable	DCIProtectionT2(s)	1.00					
	Setting																																																																				
	Others Parameters																																																																				
	Others																																																																				
	PowerOnDelay(s)	300																																																																			
	ReactivePowerStep	25.00%																																																																			
	eErrSoftStarTms	300																																																																			
	eNormSoftStopTms	1	Enable																																																																		
	eNormSoftStartTms	1																																																																			
	NormalDeratingStep	100.00%																																																																			
Others																																																																					
PVSlowStartStep	10.00%	Disable																																																																			
PVSlowStartPwDelta	5.00%																																																																				
FaultPowerT(C)	95.0																																																																				
FaultEnvT(C)	83.0																																																																				
Others																																																																					
GFCIStaticValue(mA)	540																																																																				
GFCIStaticT(s)	0.2	Enable																																																																			
GFCIDynProFactor	100.0%	Enable																																																																			
DCIProtection1	0.50%	Enable																																																																			
DCIProtectionT1(s)	60.00																																																																				
DCIProtection2(mA)	950	Disable																																																																			
DCIProtectionT2(s)	1.00																																																																				
	<table border="1"> <tr><td colspan="3">Others</td></tr> <tr><td>PVStartupVolt(V)</td><td>330</td><td></td></tr> <tr><td>MPPTScanPeriod(s)</td><td>3600</td><td>Disable</td></tr> <tr><td>ISOProtection(ohm)</td><td>100K</td><td>Enable</td></tr> <tr><td>StartUPMinTemp(C)</td><td>-30.0</td><td></td></tr> <tr><td>DuplicationControl</td><td>0%</td><td></td></tr> <tr><td>CtrParaGroup</td><td>4</td><td></td></tr> <tr><td>PID Check Settings</td><td>0</td><td></td></tr> </table> <p style="text-align: right;">P4/8</p>	Others			PVStartupVolt(V)	330		MPPTScanPeriod(s)	3600	Disable	ISOProtection(ohm)	100K	Enable	StartUPMinTemp(C)	-30.0		DuplicationControl	0%		CtrParaGroup	4		PID Check Settings	0		<table border="1"> <tr><td colspan="3">Others</td></tr> <tr><td>Island Protect</td><td>Enable</td><td></td></tr> <tr><td>FAN Detect</td><td>Enable</td><td></td></tr> <tr><td>Reserve</td><td></td><td></td></tr> <tr><td>OperationOverVol</td><td>120.00%</td><td>Disable</td></tr> <tr><td>VirtualDamping</td><td>0.000</td><td></td></tr> <tr><td>Reserve</td><td></td><td></td></tr> </table> <p style="text-align: right;">P5/8</p>	Others			Island Protect	Enable		FAN Detect	Enable		Reserve			OperationOverVol	120.00%	Disable	VirtualDamping	0.000		Reserve			<table border="1"> <tr><td colspan="3">Others</td></tr> <tr><td>Mppt1_OptVolLowLim</td><td>200.0</td><td></td></tr> <tr><td>Mppt1_OptVolUpLim</td><td>1000.0</td><td></td></tr> <tr><td>Mppt2_OptVolLowLim</td><td>200.0</td><td></td></tr> <tr><td>Mppt2_OptVolUpLim</td><td>1000.0</td><td></td></tr> <tr><td>Mppt3_OptVolLowLim</td><td>200.0</td><td></td></tr> <tr><td>Mppt3_OptVolUpLim</td><td>1000.0</td><td></td></tr> </table> <p style="text-align: right;">P6/8</p>	Others			Mppt1_OptVolLowLim	200.0		Mppt1_OptVolUpLim	1000.0		Mppt2_OptVolLowLim	200.0		Mppt2_OptVolUpLim	1000.0		Mppt3_OptVolLowLim	200.0		Mppt3_OptVolUpLim	1000.0	
Others																																																																					
PVStartupVolt(V)	330																																																																				
MPPTScanPeriod(s)	3600	Disable																																																																			
ISOProtection(ohm)	100K	Enable																																																																			
StartUPMinTemp(C)	-30.0																																																																				
DuplicationControl	0%																																																																				
CtrParaGroup	4																																																																				
PID Check Settings	0																																																																				
Others																																																																					
Island Protect	Enable																																																																				
FAN Detect	Enable																																																																				
Reserve																																																																					
OperationOverVol	120.00%	Disable																																																																			
VirtualDamping	0.000																																																																				
Reserve																																																																					
Others																																																																					
Mppt1_OptVolLowLim	200.0																																																																				
Mppt1_OptVolUpLim	1000.0																																																																				
Mppt2_OptVolLowLim	200.0																																																																				
Mppt2_OptVolUpLim	1000.0																																																																				
Mppt3_OptVolLowLim	200.0																																																																				
Mppt3_OptVolUpLim	1000.0																																																																				
	<table border="1"> <tr><td colspan="3">Others</td></tr> <tr><td>Anti reflux(DSP)</td><td>0.00</td><td>Disable</td></tr> <tr><td>Anti reflux(LCD)</td><td>0</td><td></td></tr> </table> <p style="text-align: right;">P7/8</p>	Others			Anti reflux(DSP)	0.00	Disable	Anti reflux(LCD)	0		<table border="1"> <tr><td colspan="3">Others</td></tr> <tr><td>RepidShutdownEn</td><td>Enable</td><td></td></tr> </table> <p style="text-align: right;">P8/8</p>	Others			RepidShutdownEn	Enable																																																					
Others																																																																					
Anti reflux(DSP)	0.00	Disable																																																																			
Anti reflux(LCD)	0																																																																				
Others																																																																					
RepidShutdownEn	Enable																																																																				

Figure 7-15 **OTHERS** Parameter Setting

Table 7-11 Others Submenu Parameters Setup Ranges with Lower Limit, Default, and Upper Limit Settings

**OTHER
PARAMETERS**

SETTING RANGE

PARAMETER NAME	DESCRIPTION	IEEE 1547-2018			RULE 21			ISO-NE		
		MIN	DEF	MAX	MIN	DEF	MAX	MIN	DEF	MAX
POWERONDELAY (S)	Startup delay time	1	300	1200	1	300	1200	1	300	1200
REACTIVEPOWER STEP (%/P)	Reactive Step	0.01	25.00	600.00	0.01	25.00	600.00	0.01	25.00	600.00
ERRSOFTSTARTP (S)	Power startup step after Grid Fault	1	300	1000	1	500	1000	1	600	1000
NORMSOFTSTOPP (S)	Normal power step in soft stop	1	1	1000	1	10	1000	1	10	1000
NORMSOFTSTARTP (S)	Normal power step in soft startup	1	1	1000	1	10	1000	1	50	1000
NORMDERATINGSTEP	Normal Power Derating step (Includes step up from a Derate)	0.01	100.0	100.00	0.01	100.0	100.00	0.01	6.00	100.00
PVSLOWSTARTSTEP (%)	PVSlowStartStep	0.01	10.00	100.00	0.01	10.00	100.00	0.01	10.00	100.00
PVSLOWSTARTPWDELTA	PV power sudden change slow start power limit increment	0.01	5.00	10.00	0.01	5.00	10.00	0.01	5.00	10.00
FAULTPOWERT (°C)	The trigger temperature of module	95.0	95.0	95.0	95.0	95.0	95.0	95.0	95.0	95.0
FAULTENVT (°C)	The trigger temperature of environment	83.0	83.0	83.0	83.0	83.0	83.0	83.0	83.0	83.0
GFCISTATICVALUE (mA)	The static threshold value of Leakage current	100	540	1000	100	540	1000	100	540	1000
GFCISTATIC (S)	GFCI static protection time	0.00	0.20	655.00	0.00	0.20	655.00	0.00	0.20	655.00
GFCIDYNPROFACTOR	GFCI dynamic protection factor	0.0	100.0	200.0	0.0	100.0	200.0	0.0	100.0	200.0
DCIPROTECTION1	Maximum DCI value1	0.1	0.5	5.0	0.1	0.5	5.0	0.1	0.5	5.0
DCIPROTECTIONT1 (S)	Trip time 1 of DCI value	0.00	60.00	120.00	0.00	60.00	120.00	0.00	60.00	120.00
DCIPROTECTION2 (mA)	maximum DCI value2	5	950	5000	5	950	5000	5	950	5000

DCIPROTECTIONT2 (S)	Trip time 2 of DCI	0.00	1.00	120.00	0.00	1.00	120.00	0.00	1.00	120.00
PVSTARTUPVOLT (V)	PV start-up voltage	300	330	400	300	330	400	300	330	400
MPPTSCANPERIOD (S)	MPPTScan Cycle	300	3600	5400	300	3600	5400	300	3600	5400
ISOPROTECTION (KΩ)	Minimum insulation	1	100	2000	1	100	2000	1	100	2000
STARUPMINTEMP (°C)	The minimum startup temperature	-35	-30	-20	-35.0	-30	-20	-35	-30	-20
DUPLICATION GROUP	Parameter of repetitive	0	0	100	0	0	100	0	0	100
CTRPARGROUP	The enabled control parameters group	0	4	4	0	4	4	0	4	4
PID CHECK SETTING *	PID Checking enable/disable	0	0	1	0	0	1	0	0	1
ISLAND PROTECT	Island enable/disable control 0: Disable 1: Enable	0	1	1	0	1	1	0	1	1
FAN DETECT	Fan detection enable/disable control 0: Disable 1: Enable	0	1	1	0	1	1	0	1	1
RAPIDSHUTDOWNEN	Fast Shutdown Enable control 0: Disable 1: Enable	0	0	1	0	0	1	0	0	1
OPERATIONOVERVOL	Operating overvoltage protection value	100	120	135	100	120	135	100	120	135
VIRTUALDAMPING	The parameter of Virtual Damping	0	0	5	0	0	5	0	0	5
MPPT1_OPTVOLLOW LIM	Mppt1 optimizer's Voltage lower limit	200	200	1500	200	200	1500	200	200	1500
MPPT1_OPTVOLUPLIM	Mppt1 optimizer's Voltage upper limit	200	1000	1500	200	1000	1500	200	1000	1500
MPPT2_OPTVOLLOW LIM	Mppt2 optimizer's Voltage lower limit	200	200	1500	200	200	1500	200	200	1500
MPPT2_OPTVOLUPLIM	Mppt2 optimizer's Voltage upper limit	200	1000	1500	200	1000	1500	200	1000	1500
MPPT3_OPTVOLLOW LIM	Mppt3 optimizer's Voltage lower limit	200	200	1500	200	200	1500	200	200	1500
MPPT3_OPTVOLUPLIM	Mppt3 optimizer's Voltage upper limit	200	1000	1500	200	1000	1500	200	1000	1500
ANTI REFLUX(DSP)	DSP anti-backflow communication delay	0.5	0	60	0.5	0	60	0.5	0	60
ANTI REFLUX(LCD)	LCD anti-backflow communication delay	0	0	255	0	0	255	0	0	255

NOTICE!

Compatibility among the functions:

- Only one of these four functions can be valid at one time: QU, PF(P), PF Setting and reactive power setting.
- LVRT will take priority over the following functions:
 - Anti-islanding, QU, PF(P), PF Setting, reactive power setting, active power setting, over frequency derating, GFCI, Grid over frequency protection, Grid unbalance protection, DCI protection.

7.1.3 Power ON/OFF

7.1.3.1 Manual Power ON/OFF

Restarting the inverter is required after changing a parameter setting or manual (fault) shut-down. Press **ESC** or **ENT** to access the **MAIN MENU**. Scroll the cursor down to highlight POWER ON/OFF and press **ENT** to select. Move the cursor to “ON” and press **ENT** to start the inverter. The inverter will start up and operate normally if the start-up conditions are met. Otherwise, the inverter will go to stand-by mode.

Normally, it is not necessary to Turn OFF the inverter, but it can be shut down manually if regulation setting or maintenance is required. Move the cursor from the main operation interface to POWER ON/OFF and press **ENT**. Move the cursor to “OFF” and press **ENT**, and then the inverter will be shut down.

7.1.3.2 Automatic Power ON/OFF

The inverter will start up automatically when the output voltage and power of PV arrays meet the set value, AC power grid is normal, and the ambient temperature is within allowable operating range.

The inverter will be shut down automatically when the output voltage and power of PV modules are lower than the set value, the AC power grid fails, or the ambient temperature exceeds the normal range.

7.1.4 History Record

Move the cursor to **HISTORY RECORD** in the **MAIN MENU** interface. Press **ENT** to check the historical records. There are 3 submenus in the **HISTORY RECORD** menu: **CURRENT ERROR**, **RUNNING RECORD** and **FAULT RECORD**. See Figure 7-.

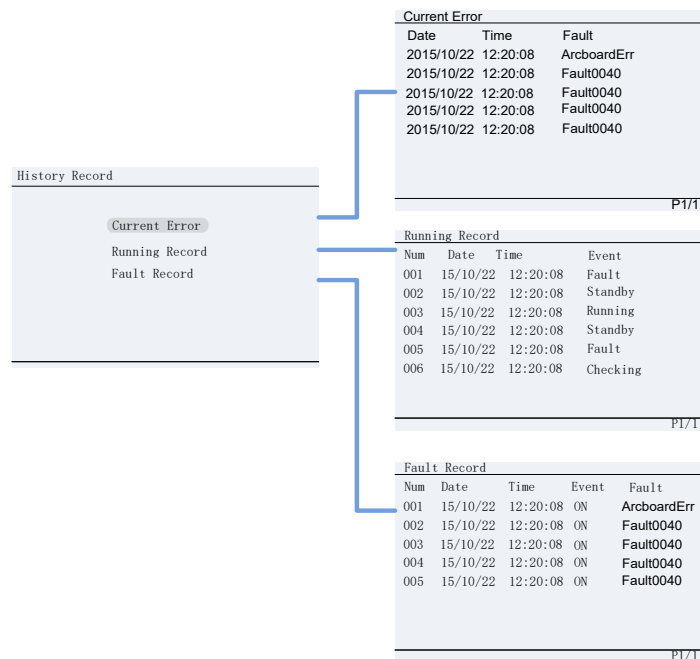

Figure 7-19 History Submenu

CURRENT ERROR This log will display any faults that are currently affecting the operation of the inverter.

RUNNING RECORD This log can store up to 128 running history messages. This includes normal operating events such as the inverter turning on, going into standby and turning off.

FAULT RECORD This log can store up to 128 fault codes.

7.1.5 Device Information

Press the ESC key to leave the main “operation interface” and press ENT to access the **MAIN MENU**. Using the arrow keys, scroll down to the **DEVICE INFORMATION** submenu and press ENT to check the device information, as shown in Figure 7-.

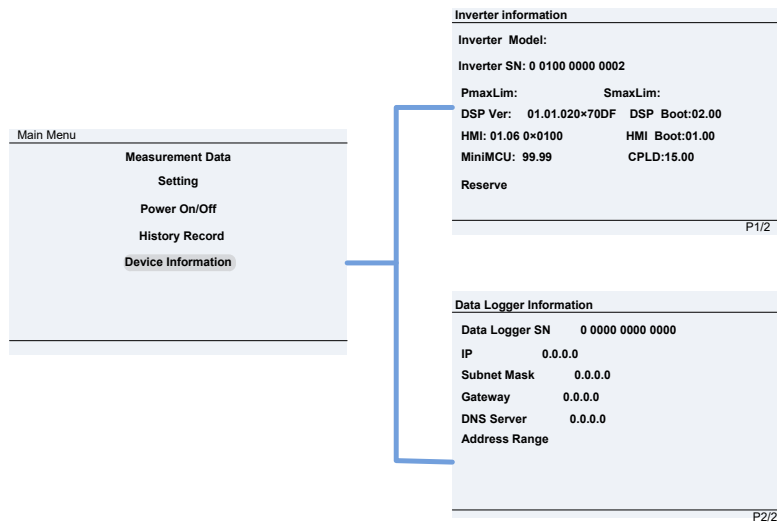

Figure 7-20 Device Information

This menu provides the information to identify the version of boards in the inverter, model number, serial number and data logger information. This information may be required when contacting Yaskawa Solectria Solar service.

WARNING

Please follow the guidelines below before on-grid operation to eliminate possible dangers and to ensure safety.

7.1.6 Start-Up

Automatic start-up: The inverter will start up automatically when the output voltage and power of PV arrays meet the set value, AC power grid is normal, and the ambient temperature is within allowable operating range.

Manual Power ON/OFF: Manual Power ON/OFF is required after regulation setting or manual (fault) shut-down. Press **ESC** to and **ENT** to access the **MAIN MENU**, move the cursor to “ON/OFF” and press **ENT**. Once in the “ON/OFF” submenu, move the cursor to “ON” and press **ENT** to start the inverter. Then the inverter will start up and operate normally if the start-up condition is met. Otherwise, the inverter will go to stand-by mode.

7.1.7 Shut-Down

Automatic shutdown: The inverter will be shut down automatically when the output voltage and power of PV modules are lower than the set value, AC power grid fails, or the ambient temperature exceeds the normal range.

Manual shutdown: Normally, it is not necessary to shut down the inverter, but it can be shut down manually if regulation setting or maintenance is required.

Press **ESC** and then **ENT** to access the **MAIN MENU**. Move the cursor to the submenu Manual Power ON/OFF and press **ENT**. Move the cursor to “OFF” and press **ENT**, and then the inverter will shut down.

7.1.8 Grid-tied Power Generation

The inverters have an automatic grid-tied power generation process. It constantly checks whether the AC grid meets the conditions for grid-tied power generation and test whether the PV array has adequate energy. After all conditions are met, the inverter will enter into Normal Operation mode and export power to the grid. While generating power, the inverter can detect the grid at all times, supply current, match the voltage and frequency of the grid, and keep the photovoltaic array output at the maximum power point. In case of any grid abnormality, the inverter will enter the protection program immediately. In low light conditions when PV power generation is not sufficient to keep the inverter in operation, the inverter will enter into standby mode. When the voltage of PV array changes, becomes stable and higher than the required start value, the inverter will attempt to start grid-tied power generation again.

7.1.9 File Export (local)

File Export is used to export the data including Running History and Fault Record to a flash drive. Press **ENT** and use **UP** and **DOWN** arrows to export the data, and press **ENT** to confirm the setting.

7.1.10 Firmware Upgrade

Update the firmware by using a USB flash drive:

1. Obtain a USB flash drive (Capacity less than 8G) and format the drive to FAT32.
 - a. Insert the USB flash drive into a computer.
 - b. When the USB drive appears in the File Explorer Right click the drive and select "Format...". The File system should display "FAT32" as default. If not, make this selection and click "start."
2. Obtain a copy of the LCD firmware file and the DSP firmware file from Yaskawa Solectria Solar's technical support team and copy them into the USB flash drive. The upgrade files need to be placed in the root directory. Contact Yaskawa Solectria Solar's after-sales technical service team for the latest firmware files.
3. Insert the USB flash drive into USB port on the inverter's communications board.

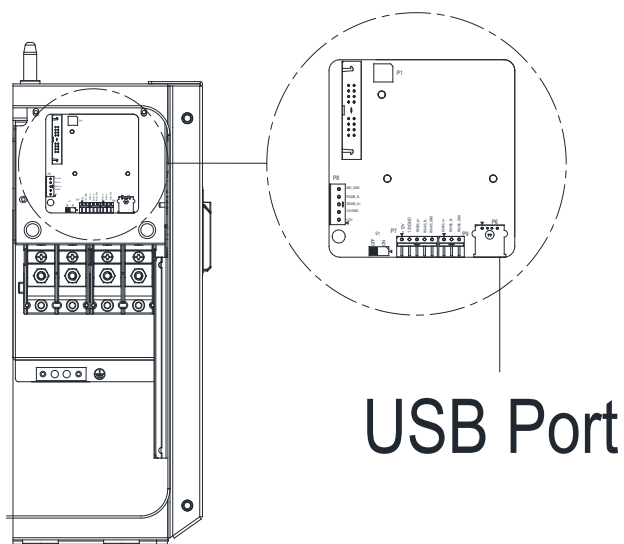

Figure 7-21 USB Port for Firmware Upgrades

4. Using the same password to enter the **SETTING** menu and select “Firmware Update”. Choose the firmware to be updated (LCD or DSP) and follow the prompts on the screen. See Figure 7-16.
5. When the update is successful repeat the process, if necessary, to update the next firmware (DSP or LCD). Should the update fail, return to step 4 when prompted and repeat the process.

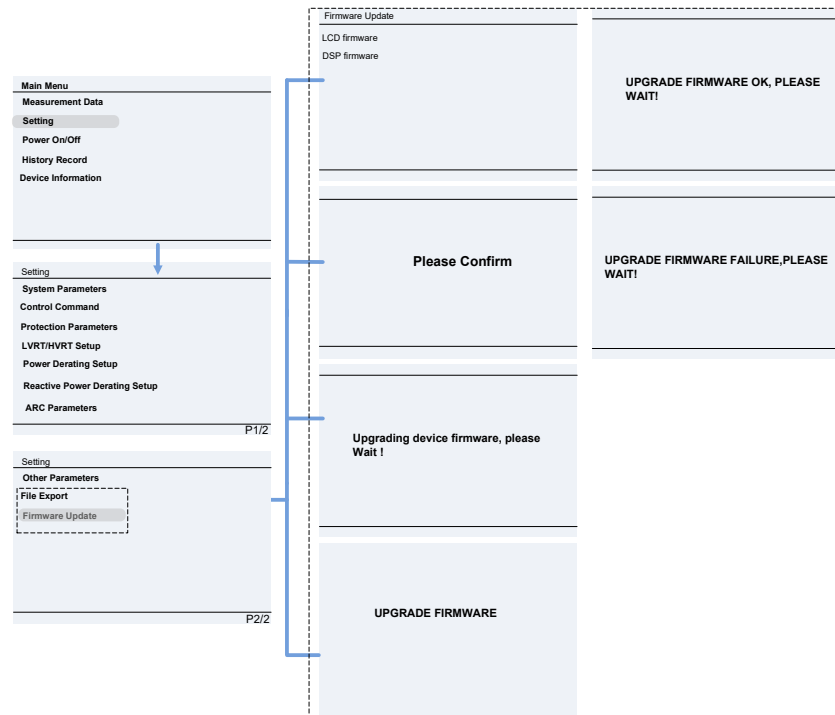

Figure 7-16 Firmware Upgrade Interface

INFO ✓

File Export and Firmware Update need super user rights.

8. Fault Shutdown and Troubleshooting

If a fault occurs within the system, the inverter will recognize and report via the LED or LCD panel. If this occurs, reference the following section and serial number of the inverter prior to contacting Yaskawa Solectria Solar for support. This will ensure the quickest time to resolution possible. If the fault is regarding a voltage issue, please measure the AC and DC voltage at the inverter prior to calling

8.1 LED Status Panel Testing

Please see Table 5-1 for the LED Status Panel explanation and troubleshoot according to Table 8-1.

Table 8-1 Troubleshooting using the LED light indicators

LED FAULT STATUS	SOLUTIONS
NEITHER THE “POWER” LED NOR THE LCD SCREEN LIGHTS UP.	<ol style="list-style-type: none"> 1. Turn off the external AC breaker 2. Switch the DC switch to “OFF” position 3. Check the PV input voltage and polarity
THE “GRID” LED IS BLINKING.	<ol style="list-style-type: none"> 1. Turn off the external AC breaker 2. Switch the DC switch to “OFF” position 3. Check whether the grid voltage is normal and whether the cable connection of AC side is correct and secure
THE “RUN” LED LIGHTS OFF OR “FAULT” LED LIGHTS UP.	Refer to Table 8-2 for troubleshooting

8.2 LCD Fault and Troubleshooting

DANGER

Electric Shock Hazard: Disconnect the inverter from the AC grid and PV modules before opening equipment. Make sure hazardous high voltage and energy inside the wiring box has been discharged. Wait at least 5 minutes after disconnecting all power sources before opening and maintaining the inverter.

The inverter will shut down automatically if the PV power generation system fails, such as from a short circuit on the output lines, grid overvoltage / under-voltage, grid over-frequency / under-frequency, high ambient temperature or internal malfunction of the machine. The fault information will be displayed on the LCD screen. Please refer to 7.1.4 History Record for detailed operation.

The causes of a fault can be identified based on the faults listed in Table 8-2. Proper analysis is recommended before contacting customer service. There are 4 types of faults: alarm, warn, protection and hardware faults.

WARNING

Operating the DC Switch: The DC Switch is rated to break loads under normal operating conditions. However, a DC short circuit could be hazardous and the following procedures should be followed before turning OFF the DC Switch under fault conditions.

WARNING

All the installation and wiring connections should be performed by qualified technical personnel. Disconnect the inverter from PV modules and the AC supply before undertaking maintenance.

Do not operate or maintain the inverter until at least 5 minutes after disconnecting all sources of DC and AC.

Table 8-2 Fault Codes and Recommended Solutions

FAULT CODE	EXPLANATION
ALARM	
TEMPSENSORERR	<p>Definition:</p> <p style="padding-left: 40px;">Detection of abnormal temperature</p> <p>Possible causes:</p> <p style="padding-left: 40px;">Temperature Sensor socket connector has poor contact.</p> <p style="padding-left: 40px;">Temperature Sensor is damaged.</p> <p>Recommended solutions:</p> <ol style="list-style-type: none"> 1. Observe temperature display. 2. Switch off external AC disconnect, then back on to reboot the system. 3. Contact post-sales service if not corrected.
COMMERR	<p>Definition:</p> <p style="padding-left: 40px;">Communication inside inverter failed</p> <p>Possible causes:</p> <p style="padding-left: 40px;">Terminal block connectors of internal communication wires have poor contact.</p> <p>Recommended solutions:</p> <ol style="list-style-type: none"> 4. Observe for 5 minutes and see whether the alarm will stop automatically. 5. Switch off external AC disconnect, then back on to reboot the system.

<p>EXTFANERR</p>	<p>6. Contact the technical support team.</p> <p>Definition:</p> <p>Cooling fan failure</p> <p>Possible causes:</p> <ol style="list-style-type: none"> 1. Fan is blocked. 2. Fan service life has expired. 3. Fan socket connector has poor contact. <p>Recommended solutions:</p> <ol style="list-style-type: none"> 1. Observe for 5 minutes and see whether the alarm will stop automatically. 2. Check for foreign objects on fan blades. 3. Switch off external AC disconnect, then back on to reboot the system. 4. Contact the technical support team.
<p>EEPROMERR</p>	<p>Definition:</p> <p>Internal Alarm</p> <p>Possible Cause:</p> <p>Internal Memory has a problem.</p> <p>Recommended solutions:</p> <ol style="list-style-type: none"> 1. Observe for 5 minutes and see whether the alarm will stop automatically. 2. Contact after-sales technical support team.
<p>WARNING</p>	
<p>WARN0030 (EEPROMERR)</p>	<p>Definition:</p> <p>Internal alarm</p> <p>Possible causes:</p> <p>Internal memory has a problem.</p>

	<p>Recommended solutions:</p> <ol style="list-style-type: none"> 1. Observe for 5 minutes and see whether the alarm will stop automatically. 2. Contact the post-sales technical support team.
<p>WARN0050 (TEMPSENSORERR)</p>	<p>Recommended solutions:</p> <ol style="list-style-type: none"> 1. Observe temperature display. 2. Switch off external AC disconnect, then back on to reboot the system. 3. Contact the technical support team.
<p>ExtFanErr</p>	<p>Recommended solutions:</p> <p>When the inverter is displaying "ExtFanErr" and the output power of the inverter is greater than 50% of it's rated output, do the following:</p> <ol style="list-style-type: none"> 1. If the fan is spinning --> Replace the inverter because the sensing circuit has a problem. 2. If the fan is not spinning --> Remove the 6 bolts that are holding the two external fans in place. Open the white, snap-on wire connector. Measure the voltage between the pins connected to the RED and BLACK wires. If the voltage is below 6VDC --> Replace the inverter. If the voltage is higher than 6V --> Replace the fan.
<p>IntFanErr</p>	<p>Replace the inverter</p>
<p>Warn0040 (DC SPD)</p>	<p>Recommended solutions:</p> <ol style="list-style-type: none"> 1. Visually check the DC Surge Protection Device (SPD) 2. If the indicator is "red" --> Replace the SPD module. 3. If the indicator is "green" --> Remove and reinstall SPD module in the socket. <p>Contact post-sales service if not corrected</p>
<p>Warn0100 (AC SPD)</p>	<p>Recommended solutions:</p> <ol style="list-style-type: none"> 1. Visually check the DC Surge Protection Device (SPD) 2. If the indicator is "red" --> Replace the SPD module. 3. If the indicator is "green" --> Remove and reinstall SPD module in the socket. <p>Contact post-sales service if not corrected</p>

PROTECTION	
PROTECT0090 (BUS OVER VOLTAGE)	<p>Recommended solutions:</p> <ol style="list-style-type: none"> 1. Restart inverter by turning both AC and DC switches OFF. Wait for 1 minute for all energy to discharge and turn both switches ON. 2. If inverter cannot clear fault, replace inverter.
PROTECT0070 (BUS IMBALANCE)	<p>Recommended solutions:</p> <ol style="list-style-type: none"> 1. Raise limit of IDCmax (for example, 400mA) to allow inverter more room to adjust in transient condition to cope with imbalance of impedance and voltage between grid phases. 2. If alarm still occurs after adjustment, replace inverter.
PROTECT0030 (INVERTER OVER CURRENT)	<p>Recommended solutions:</p> <ol style="list-style-type: none"> 1. Restart inverter by turning both AC and DC switches OFF. Wait for 1 minute for all energy to discharge and turn both switches ON. 2. If inverter cannot clear fault, replace inverter.
GRIDV.OUTLIM	<p>Recommended solutions:</p> <ol style="list-style-type: none"> 1. Check the AC connections and that AC voltage is within range. 2. Restart the inverter.
GRIDF.OUTLIM	<p>Recommended solutions:</p> <ol style="list-style-type: none"> 1. Check the AC wires connection and that AC frequency is in range. 2. Check the measured frequency value on the LCD, if the grid frequency is within limit, restart the inverter.
PROTECT0020 (GRID RELAY ERROR)	<p>Recommended solutions:</p> <ol style="list-style-type: none"> 1. Restart inverter by turning both AC and DC switches OFF. Wait for 1 minute for all energy to discharge and turn both switches ON. 2. If inverter cannot clear fault, replace inverter.
TEMPOVER	<p>Recommended solutions:</p>

<p>(OVER-TEMPERATURE PROTECTION)</p>	<ol style="list-style-type: none"> 1. Confirm that external ambient temperature is within the specified range of operating temperature. 2. Check whether the air inlet is blocked. 3. Check whether the fan is blocked. 4. Check whether the location of installation is appropriate or not. 5. Observe for 30 minutes and see whether the alarm will stop automatically. 6. Contact the technical support team.
<p>PROTECT0180 (THE SAMPLING OFFSET OF DCI)</p>	<p>Recommended solutions:</p> <ol style="list-style-type: none"> 1. If the inverter can start up, then recalibrate. 2. If the inverter consistently reports this alarm and cannot start up, then replace inverter.
<p>PROTECT0170 (DCI HIGH)</p>	<p>Recommended solutions:</p> <ol style="list-style-type: none"> 1. Raise limit of DCI_{max} (for example, 400mA) to allow inverter more room to adjust in transient condition to cope with imbalance of impedance and voltage between grid phases. 2. After raising limit, if inverter cannot clear fault, replace inverter.
<p>ISOLATIONERR (INSULATION RESISTANCE LOW)</p>	<p>Check wires of PV and ground:</p> <ol style="list-style-type: none"> 1. Turn OFF AC switch to disconnect inverter from the grid. 2. Open fuse holders to isolate PV strings. Test strings with multimeter or equivalent. 3. Add one PV string at a time, and start up inverter to see if alarm occurs. 4. If there is no alarm, turn OFF AC switches to disconnect from the grid and add in the next string. Turn AC switch on and start up inverter again. 5. Continue until you find the string that triggers the alarm. Trace back the faulted string to find any leakage to Earth Ground.

	<p>6. The parameter ISOResist in hidden menu can be adjusted.</p>
<p>GFCIERR (LEAKAGE CURRENT HIGH)</p>	<p>Check wires of PV and ground:</p> <ol style="list-style-type: none"> 1. Turn OFF AC switch to disconnect inverter from the grid. 2. Open fuse holders to isolate PV strings. Test strings with multimeter or equivalent. 3. Add one PV string at a time, and start up inverter to see if alarm occurs. 4. If there is no alarm, turn OFF AC switches to disconnect from the grid and add in the next string. Turn AC switch on and start up inverter again. 5. Continue until you find the string that triggers the alarm. Trace back the faulted string to find any leakage to Earth Ground.
<p>PROTECT0150 (MINI MCU FAULT)</p>	<p>Recommended solutions:</p> <ol style="list-style-type: none"> 1. Restart inverter by turning both AC and DC switches OFF. Wait for 1 minute for all energy to discharge and turn both switches ON. 2. If inverter cannot clear fault, replace inverter.
<p>PROTECT0110 (BUS OVER VOLTAGE (FIRMWARE))</p>	<p>Recommended solutions:</p> <ol style="list-style-type: none"> 1. Restart inverter by turning both AC and DC switches OFF. Wait for 1 minute for all energy to discharge and turn both switches ON. 2. If inverter cannot clear fault, replace inverter.
<p>PROTECT0100 (LEAKAGE CURRENT SENSOR FAULT)</p>	<p>Recommended solutions:</p> <ol style="list-style-type: none"> 1. Restart inverter by turning both AC and DC switches OFF. Wait for 1 minute for all energy to discharge and turn both switches ON. 2. If inverter cannot clear fault, contact after-sales technical support to replace Filter board or inverter.
<p>PVXREVERSE (PV REVERSE POLARITY)</p>	<p>Recommended solutions:</p> <ol style="list-style-type: none"> 1. Turn DC Switch OFF.

	<ol style="list-style-type: none"> 2. Open Fuse holders to isolate PV source circuits. 3. Use meter to find out which PV source circuit is connected in reverse polarity. 4. Correct PV source circuit connection.
<p>PVXOVERCURRENT T (PVX OVERCURRENT X=1,2,3)</p>	<p>Recommended solutions:</p> <ol style="list-style-type: none"> 1. Check PV input Current. 2. Restart inverter by turning both AC and DC switches OFF. Wait for 1 minute for all energy to discharge and turn both switches ON. 3. If inverter cannot clear fault, replace inverter.
<p>PVXVOLT OVER (PVX OVER VOLT X=1,2,3)</p>	<p>Recommended solutions</p> <ol style="list-style-type: none"> 1. Measure voltage at DC terminals in wiring box and compare with reading in MEASUREMENT DATA menu. PV voltage must be less than 1000V in open circuit condition. 2. If display reading is not within 2% of meter reading, replace inverter. 3. If display reading is within 2% of meter reading, adjust number of PV modules in the source circuit.
<p>PROTECT0230 (INVERTER OPEN- LOOP SELF-TEST FAULT)</p>	<p>Recommended solutions:</p> <ol style="list-style-type: none"> 1. Restart inverter by turning both AC and DC switches OFF. Wait for 1 minute for all energy to discharge and turn both switches ON. 2. If inverter cannot clear fault, replace inverter.
<p>ARC PROTECT</p>	<p>Recommended solutions</p> <ol style="list-style-type: none"> 1. Check if the logic connector is secured to the Arc board. 2. Run Arc Fault Test from SETTINGS Menu. 3. If Alarm re-occurs, contact Solectria after-sales technical service to replace arc board or wiring box.
<p>ARCBOARD ERR</p>	<p>Recommended solutions:</p>

	<ol style="list-style-type: none"> 1. Check if the logic connector is secured to the Arc board. 2. Run Arc Fault Test from SETTINGS Menu. 3. If Alarm re-occurs, replace arc board or wiring box.
FAULT	
FAULT0020 (BUS OVER VOLT HARDWARE)	Recommended solutions: <ol style="list-style-type: none"> 1. Restart inverter by turning both AC and DC switches OFF. Wait for 1 minute for all energy to discharge and turn both switches ON. 2. If inverter cannot clear fault, contact Technical Support.
FAULT0060 (CPLD FAULT)	Recommended solutions: <ol style="list-style-type: none"> 1. Restart inverter by turning both AC and DC switches OFF. Wait for 1 minute for all energy to discharge and turn both switches ON. 2. If inverter cannot clear fault, contact Technical Support.
FAULT0080 (BUS HARDWARE OVER CURRENT FAULT)	Recommended solutions: <ol style="list-style-type: none"> 1. Restart inverter by turning both AC and DC switches OFF. Wait for 1 minute for all energy to discharge and turn both switches ON. 2. If inverter cannot clear fault, replace inverter.
FAULT0090 (DYNAMIC LEAKAGE CURRENT HIGH)	Recommended solutions: Check wires of PV and ground. <ol style="list-style-type: none"> 1. Turn OFF AC switch to disconnect inverter from grid. 2. Open fuse holders to isolate PV strings. Test strings with meter. 3. Add one PV string and start inverter to see if alarm occurs. 4. If no alarm, turn OFF AC switches to disconnect from grid and add in the next string. Start inverter again. 5. Continue until the string that triggers the alarm is identified. Trace back the faulted string to find any leakage to Earth Ground.

<p>FAULT0100 (GRID RELAY FAULT)</p>	<p>Recommended solutions:</p> <ol style="list-style-type: none"> 1. Restart inverter by turning both AC and DC switches OFF. Wait for 1 minute for all energy to discharge and turn both switches ON. 2. If inverter cannot clear fault, replace inverter.
<p>FAULT0110 (BUS IMBALANCE)</p>	<p>Recommended solutions:</p> <ol style="list-style-type: none"> 1. Raise limit of IDCmax (for example, 400mA) to allow inverter more room to adjust in transient condition to cope with imbalance of impedance and voltage between grid phases. 2. If alarm still occurs after adjustment, replace inverter.
<p>FAULT0130 (BUS OVER TOTAL VOLTAGE)</p>	<p>Recommended solutions:</p> <ol style="list-style-type: none"> 1. Restart inverter by turning both AC and DC switches OFF. Wait for 1 minute for all energy to discharge between OFF and turn both switches ON. 2. If inverter cannot clear fault, replace inverter.
<p>FAULT0150 (OPEN-LOOP SELF-CHECK FAILURE)</p>	<p>Recommended solutions:</p> <ol style="list-style-type: none"> 1. Restart inverter by turning both AC and DC switches OFF. Wait for 1 minute for all energy to discharge and turn both switches ON 2. If inverter cannot clear fault, replace inverter.

INFO ✓

The actual display wording of “PVxVoltOver” is “PV1VoltOver” or “PV2VoltOver” or “PV3VoltOver”.
 The actual display wording of “PVxReverse” is “PV1Reverse” or “PV2Reverse” or “PV3Reverse”.
 The actual display wording of “PVxOvercurrent” is “PV1 Overcurrent” or “PV2 Overcurrent” or “PV3Overcurrent”.

9. Maintenance and Decommissioning of Inverters

This section defines the activities required to properly maintain the inverter and must be done by qualified personnel who are trained in the installation, decommissioning and maintenance of PV inverters.

9.1 Product Maintenance

Maintenance is required to ensure that the inverter remains in proper condition, prolonging service life and preventing potential issues.

9.1.1 Check Electrical Connections

Check all conductor connections during a regular maintenance inspection every 6 months to one year, depending on the temperature fluctuations at the installation site.

Check the conductor/cable connections. If loose, tighten all the terminals to proper torque, referring to Section 4 Installation

Check for damage to the conductor/cable jacket. Repair or replace any damaged conductors/cables.

9.1.2 Clean the Air Vent Grate

The inverter can become hot during normal operation. It uses built-in cooling fans to provide sufficient air flow and help in heat dissipation.

Check the air vent grate regularly to make sure it is not blocked. Clean the grate with a soft brush or vacuum cleaner attachment if necessary. The frequency of this cleaning depends on the installation environment.

9.1.3 Replace the Cooling Fans

If the internal temperature of the inverter is too high or abnormal noise is heard, assuming the air vent is not blocked and is clean, it may be necessary to replace the external fans. Please refer to Figure 9-1 for replacing the cooling fans.

- Use a No. 2 Phillips head screwdriver to remove the 10 screws on the fan tray (6 screws on the upper fan tray, and 4 screws on the lower fan tray).
- Disconnect the waterproof cable connector from the cooling fan.
- Use a No. 2 Phillips head screwdriver to remove the screws. Each fan is attached to the fan tray with 4 screws.
- Attach the new cooling fans on the fan tray and screw into place. Fasten the cable on the fan tray with cable ties.
 - Torque value: 0.8-1N.m (7.1-8.91in-lbs)
- Install the assembled fan tray back on the inverter and secure with the original screws.
 - Torque value: 1.2N.m (10.6in-lbs)

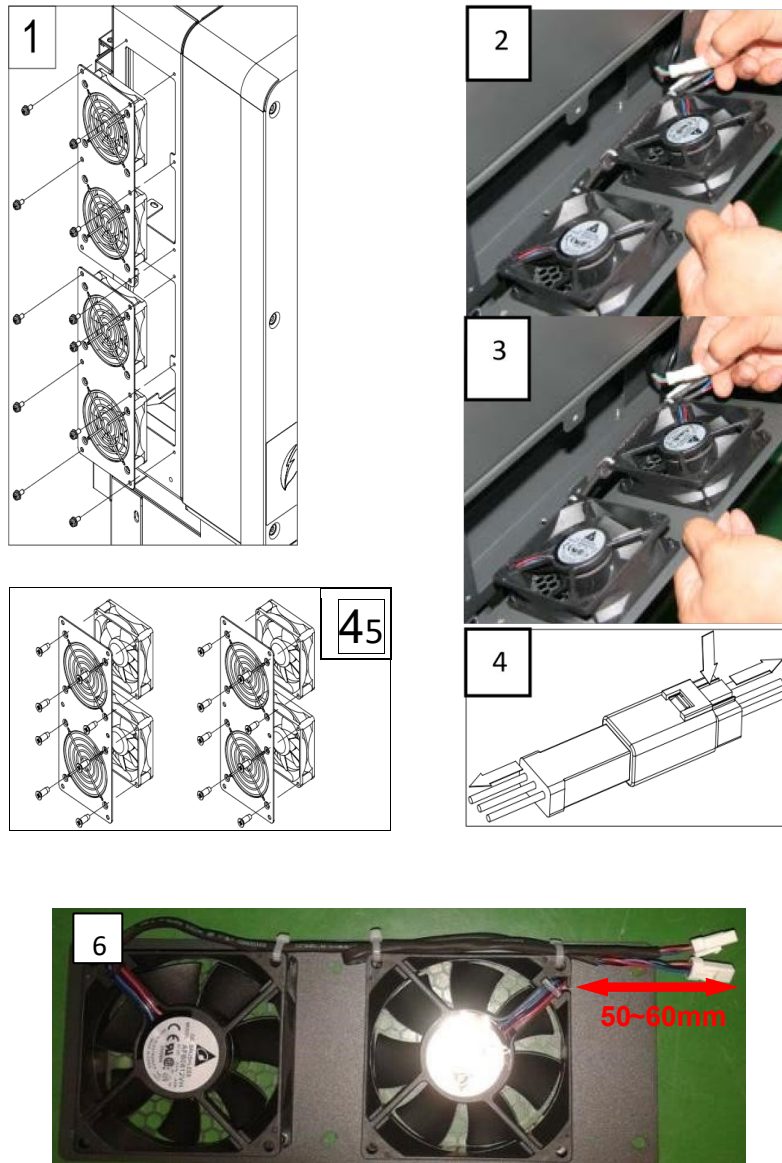

Figure 9-1 Replacing Cooling Fans

Figure 9-2 Disconnect the Main Housing from the Wiring Box

! DANGER

Electric Shock Hazard: Please disconnect the electrical connection in strict accordance with the following steps in order to avoid inverter failure or possible electrical shock that could result in death.

9.1.4 Replace the Inverter

Please confirm the following items before replacing the inverter:

- The AC breaker of inverter is turned off.
- The DC switch of the inverter is turned off.

Afterwards replace the inverter according to the following steps:

- Unlock the padlock if one is installed on the inverter.

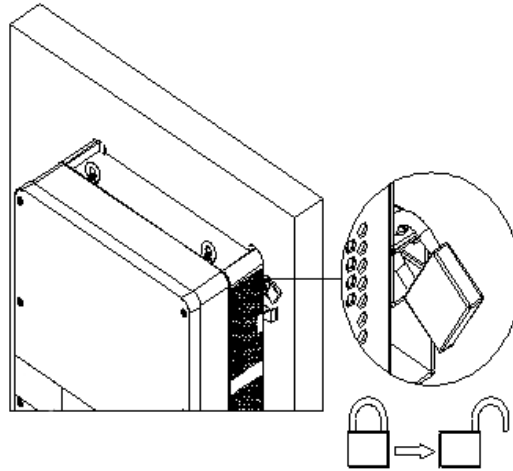

Figure 9-3 Unlock the Padlock

- Use a No. 3 Phillips head screwdriver or 10mm socket wrench to unscrew the 2 screws on both sides of the inverter.

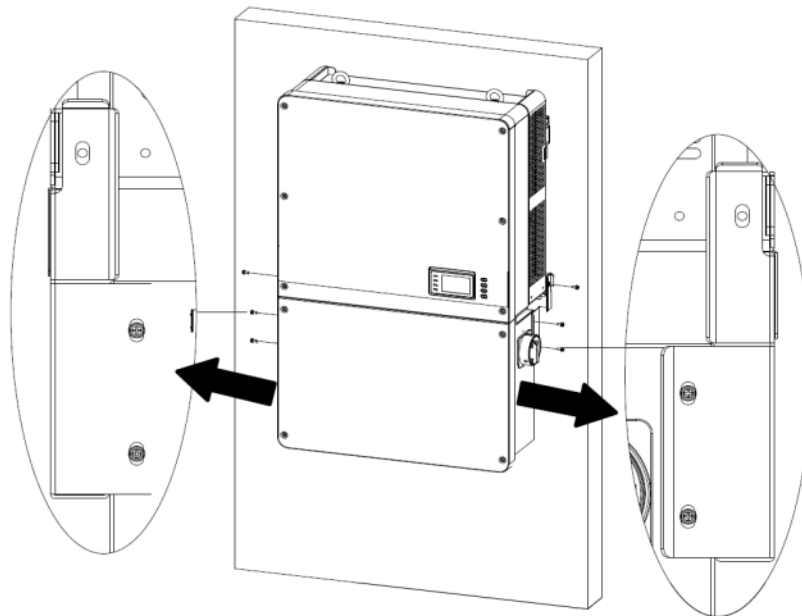

Figure 9-4 Remove the Screws on Both Sides

- Use a No. 10 Hex wrench to remove the 4 screws between the inverter and the wiring box. Lift the inverter enclosure and disconnect from the wiring box.

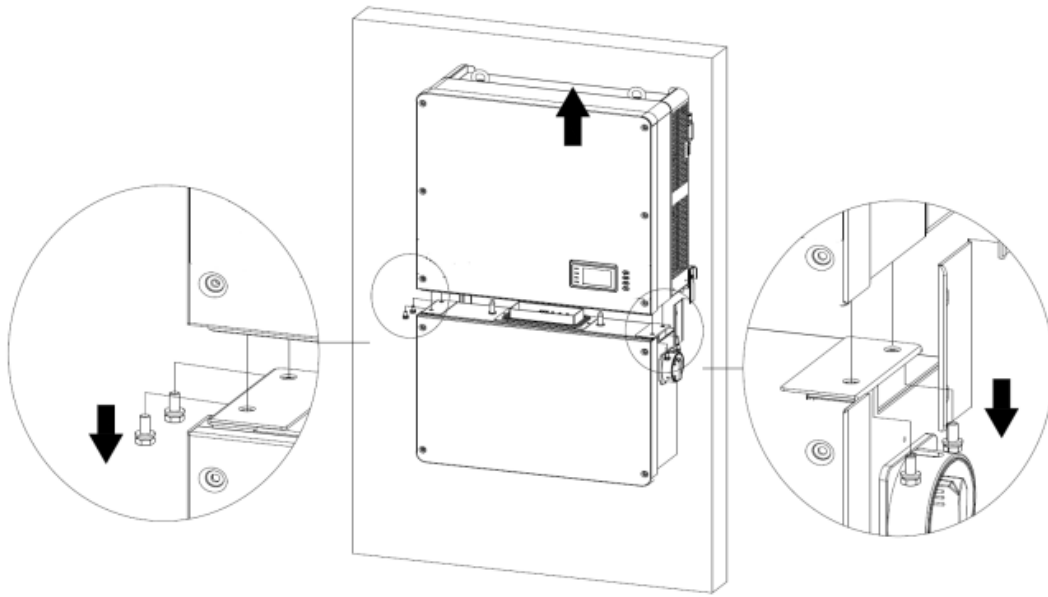

Figure 9-5 Disconnect the Main Housing from the Wiring Box

- If the replacement inverter is to be installed immediately, skip this step and refer to section 4.2.5.2 for installation of the inverter. Otherwise, use a No. 2 Phillips head screwdriver to remove the 2 screws on the left side of the wiring box, and remove the bulkhead cover. Attach the cover on the connector of wiring box.
 - Torque value: 1.6N.m (14.2in-lbs)

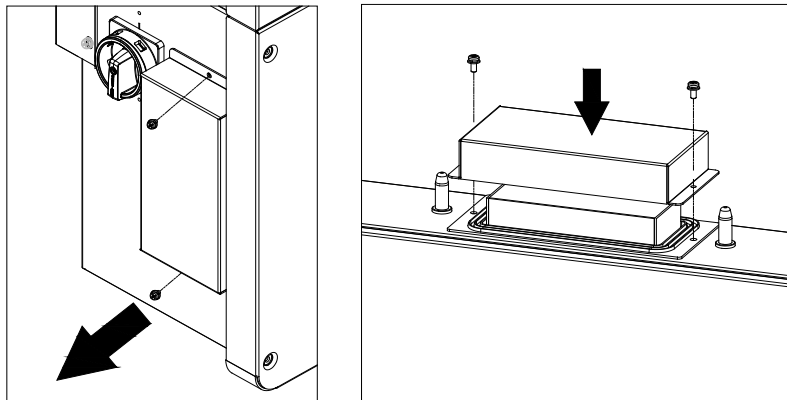

Figure 9-6 Install the cover on the connector of the Wiring Box

INFO ✓

The cover connector does not provide a watertight seal – if inverter replacement is not immediately available, additional methods of waterproofing the wire box shall be provided by the installer.

9.2 Uninstall the Inverter

Uninstall the inverter and wiring box assembly according to the following steps when the inverter needs to be removed:

- Turn off the external AC breaker and/or system disconnect switch using lock-out/tag-out procedures.
- Turn off the external DC breaker and/or disconnect switch, if present, and use lock-out/tag-out procedures. (Skip this step if there is no DC circuit breaker.)
- Switch the inverter's AC disconnect switch to "OFF" position.
- Switch the inverter's DC disconnect switch to "OFF" position.
- Wait for 5 minutes to ensure the internal capacitors have been completely discharged.
- Measure the AC output conductor terminal voltage against the ground. The meter should now read 0V.
- Disconnect the AC and EGC cables referring to "4.3.4 Electrical Installation AC".
- Disconnect the DC cables referring to "3.3.3 Electrical Installation DC".

CAUTION

Energized conductors

- If PV strings terminate directly into the wiring box and do not pass through a breaker or switch that was opened in Step 2 of Section 9.2 Uninstall the Inverter, these homerun conductors may be energized.

- Uninstall the inverter by reversing the installation steps found in section 4.2 Mechanical Installation

10. Accessories

The Yaskawa Solectria Solar PVI 25TL-208, PVI-36TL-480-V2, PVI 50TL-480, AND PVI 60TL-480 inverters have several optional accessories that allow the inverter to support a wide range of real-world applications.

10.1 Fuse Bypass Terminals

The Fuse Bypass Terminals allow for a reduction in the number of DC homeruns by combining the PV source circuits outside of the inverter wiring box and terminating with one pair of DC inputs to each of the three MPPTs. Note that external over current protection for the PV source circuits is required outside of the inverter. The MPPT positive inputs IN1+, IN2+, and IN3+ are isolated from one another by design, although the MPPT negative inputs IN1-, IN2-, and IN3- are combined via a common bus structure. The Fuse Bypass Terminals **MTLSR-070553** for the PVI-36TL-480-V2, PVI 50TL-480 and PVI 60TL-480 models only. For the PVI 25TL-208 inverter, please contact us about options.

Bypass Input Terminal Instructions

1. A maximum #2AWG wire should be used to minimize stress on the adapter.
2. Remove the wiring box cover (Figure 10-1).
3. Remove the plastic touch-safe finger guards (Figure 10-2).
4. Use a No. 2 Phillips head screwdriver to install the Bypass Terminals on each bus by fastening each terminal with the M4 screws. Torque value of 14 in-lbs (1.6 N.m) (Figure 10-3 and Figure 10-4).

5. Use a No. 10 wrench to fasten the three pairs of DC input cables to each of the Bypass Terminals at IN1+, IN2+, IN3+ (Figure 10-3) and IN1-, IN2-, IN3- (Figure 10-4) with the M6 screws. Torque value of 50 in-lbs (6.0N.m.).
6. Reinstall the plastic touch safe finger guards. Torque value #
7. Reinstall the wiring box cover. Torque to 35.4 in-lbs (4N.m).

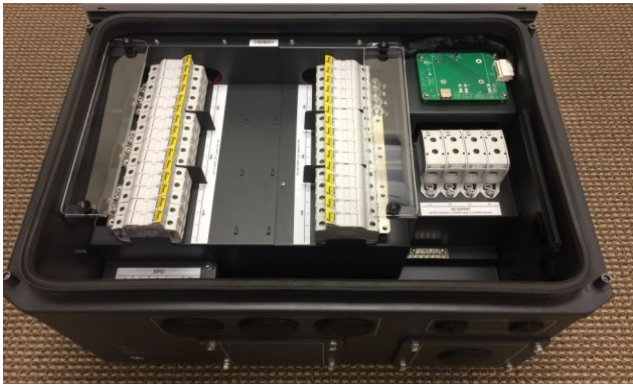

Figure 10-1 Remove Wire Box Cover

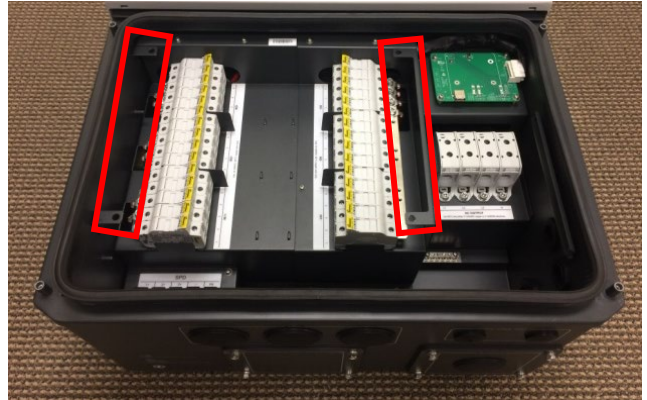

Figure 10-2 Remove Plastic Touchsafe Finger Guards

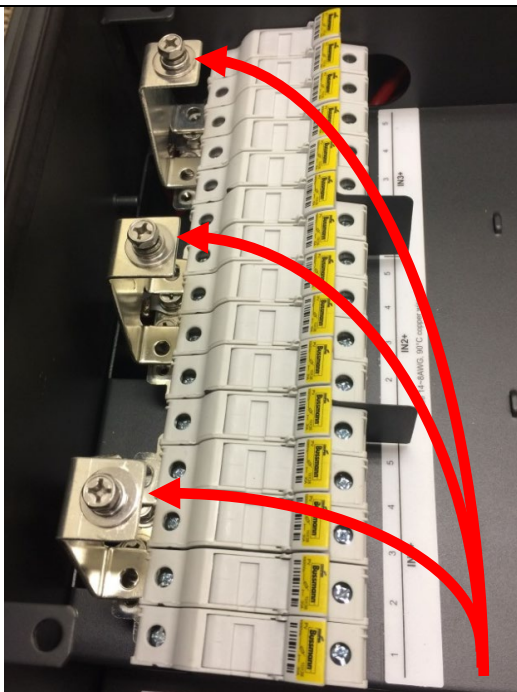

Figure 10-3 Bypass Terminals Installed on POS Input

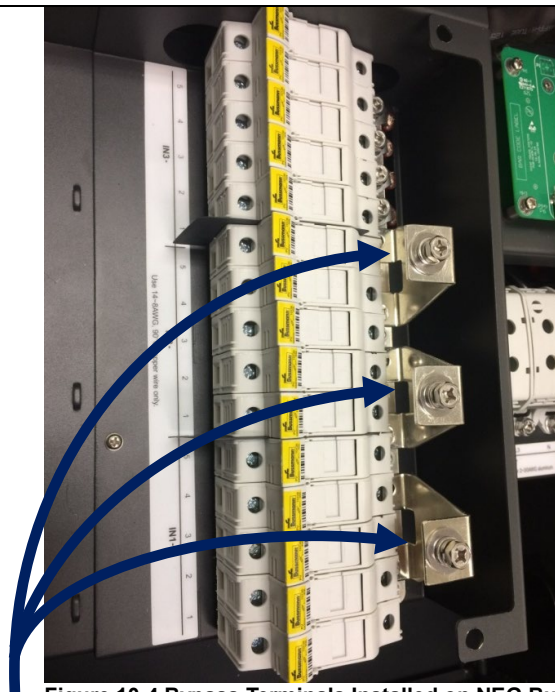

Figure 10-4 Bypass Terminals Installed on NEG Bus

10.2 Shade Cover Kit (MTLSR-070551)

MTLSR-070551 is specifically designed for inverters mounted at a 75-degree tilt angle or lower. It protects the inverter from harsh weather and direct sunlight/extremely hot temperatures while reducing thermal gain on the inverter and increasing energy production.

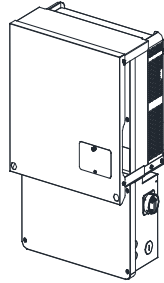

Figure 10-5 Shade Cover installed on PVI 25TL-208 or PVI-36TL-480-V2 & PVI 50/60TL-480 inverter

10.2.1 Protection from Harsh Conditions

Shade covers provide added protection for inverters against harsh environmental conditions like direct sunlight, snow, sleet, ice, hail, and reduce soiling from dust and birds. **If the Yaskawa Solectria Solar PVI 25TL-208, PVI-36TL-480-V2, PVI 50TL-480, and PVI 60TL-480 are to be mounted at any angle lower than 75° from horizontal, a shade cover is required.**

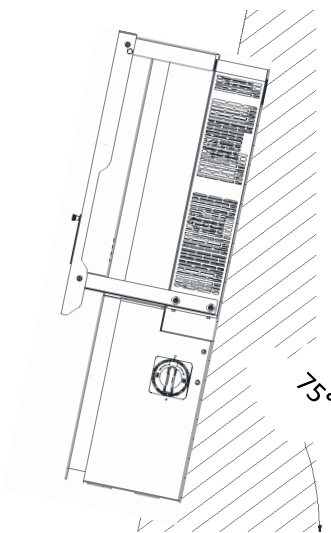

Figure 10-6 Inverter at 75° tilt from horizontal

10.2.2 Increased Energy Production

Depending on the application and environment, shade covers will help to increase energy production by reducing potential power derating due to excessive ambient temperatures. Inverters de-rate in extreme temperatures to protect themselves from over temperature conditions.

Third party field testing at PVEL showed up to 15% reduction in operating temperatures of inverters with shade covers installed in direct sunlight.

10.2.3 Shade Cover Installation

NOTICE!

Inverters at 75° or lower: If the Yaskawa Solectria Solar PVI 25TL-208, PVI-36TL-480-V2, PVI 50TL-480, and PVI 60TL-480 is to be mounted at any angle lower than 75° from horizontal, a shade cover is required.

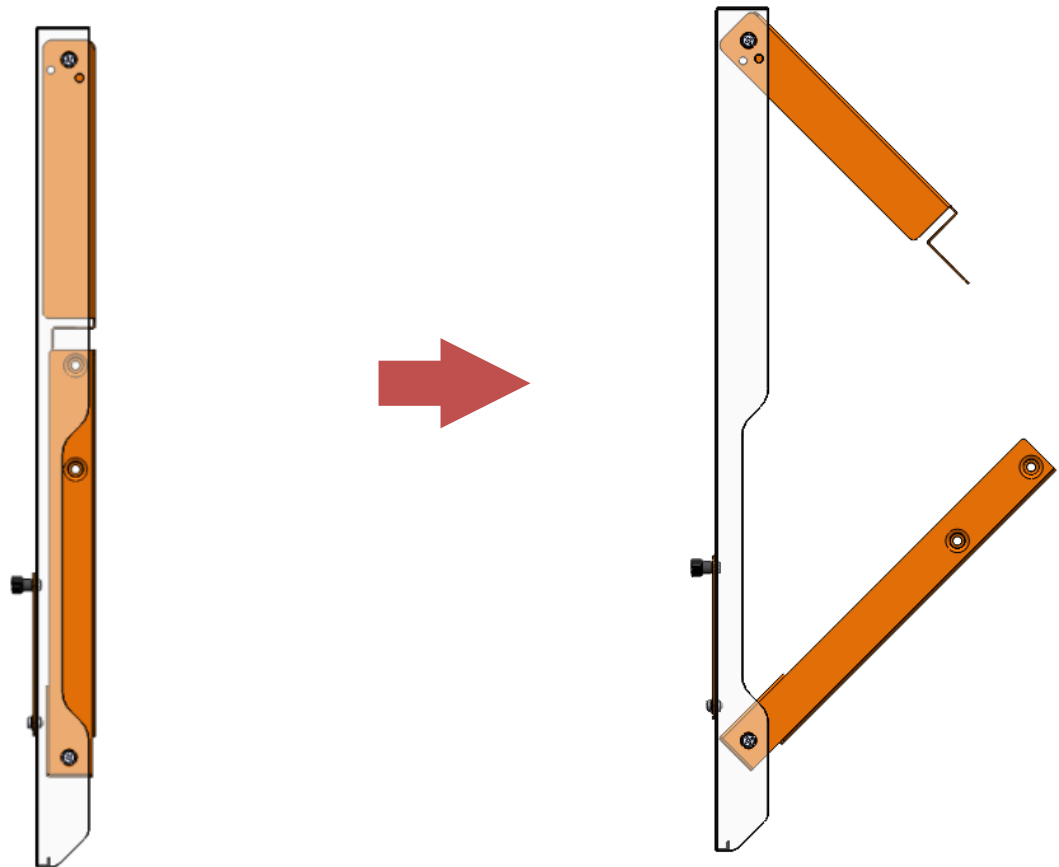

Figure 10-7 Shade Cover Installation; Steps 1 and 2

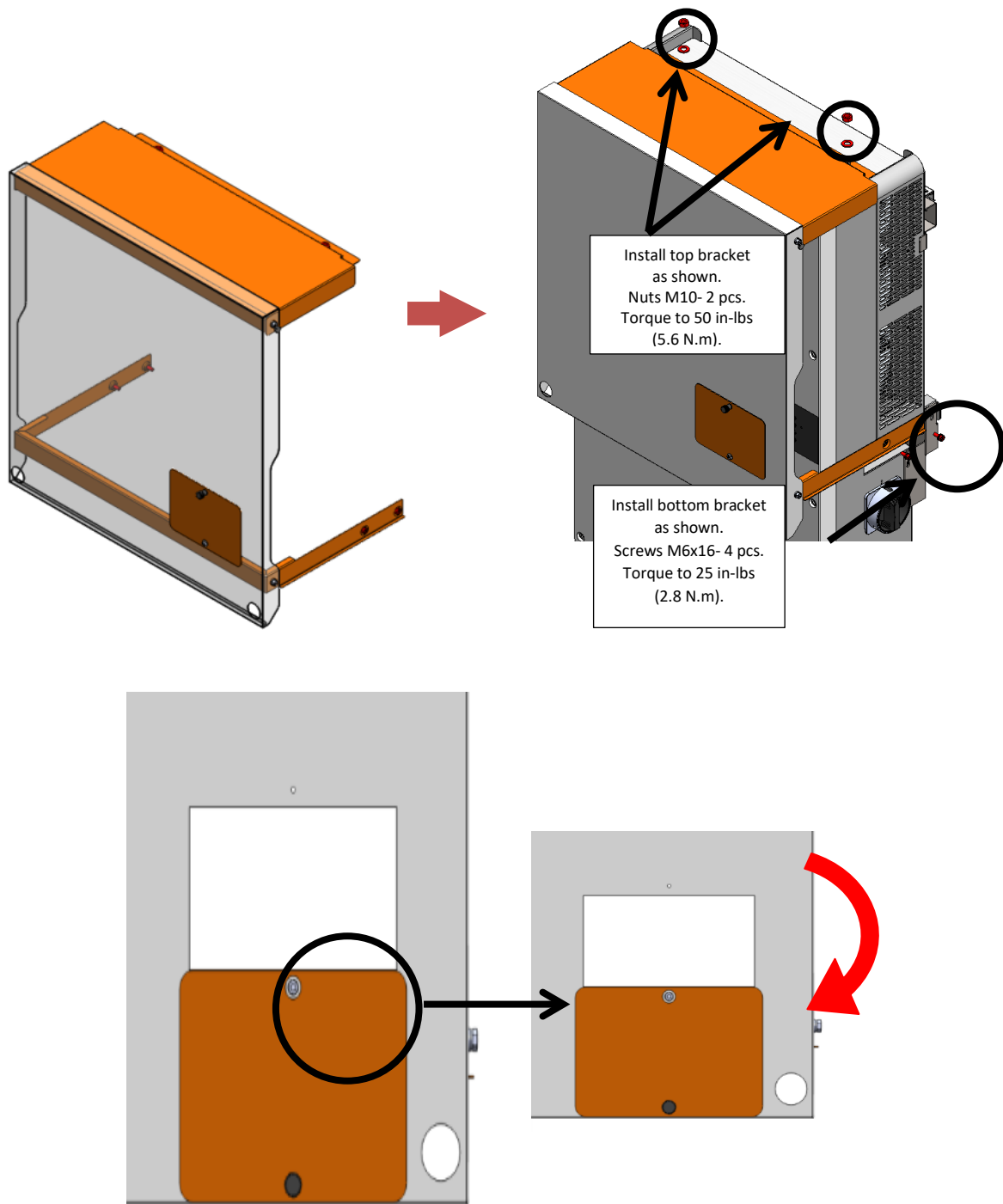

Figure 10-8 Shade Cover Installation; Steps 3 and 5

11. Technical Data

11.1 Datasheet

MODEL NAME	PVI 25TL-208	PVI-36TL-480-V2	PVI 50TL-480	PVI 60TL-480
DC INPUT				
MAX. PV POWER	45kW (17kW per MPPT)	61.2kW (22.44kW per MPPT)	90kW (33kW per MPPT)	
MAX. DC INPUT VOLTAGE	1000V _{DC}			
OPERATING DC INPUT VOLTAGE RANGE	200-950V _{DC}			
START-UP DC INPUT VOLTAGE / POWER	330V / 80W			
NUMBER OF MPP TRACKERS	3			
MPPT VOLTAGE RANGE	480-850V _{DC}	400-850V _{DC}	480-850V _{DC}	540-850V _{DC}
MAX. PV SHORT-CIRCUIT CURRENT (ISC X 1.25)	135A (45A per MPPT)	204A (68A per MPPT)		
NUMBER OF DC INPUTS	6 inputs, 2 per MPPT	15 inputs, 5 per MPPT		
DC DISCONNECTION TYPE	Load-rated DC switch			
DC SURGE PROTECTION	Type II MOV, 2800V _C , 20kA I _{TM} (8/20μS)			
AC OUTPUT				
RATED AC OUTPUT POWER	25kW	36kW	50kW	60kW
MAX. AC APPARENT POWER	25kVA	36kVA	50kVA/55kVA	60kVA/66kVA
RATED OUTPUT VOLTAGE	208V _{AC}	480V _{AC}		
OUTPUT VOLTAGE RANGE	183-229V _{AC}	422-528V _{AC}		
GRID CONNECTION TYPE	3Φ/PE/N (Physical Neutral optional)			
MAX. AC OUTPUT CURRENT @ OPERATING V_{AC}	69.5A@208 VAC	43.5A@480 VAC	60.2A/66.2A@480 VAC	72.2A/79.4A@480 VAC
MAX AC OCPD RATING	125A	125A	Suggested 125A	Suggested 125A
RATED OUTPUT FREQUENCY	60Hz			
OUTPUT FREQUENCY RANGE¹	57-63Hz			
POWER FACTOR	>0.99 (±0.8 adjustable)			
CURRENT THD	<3%			
MAX. FAULT CURRENT CONTRIBUTION (1 CYCLE RMS)	64.1A	73.2A	64.1A	
AC DISCONNECTION TYPE	Load-rated AC switch			
AC SURGE PROTECTION	Type II MOV, 1240V _C , 15kA I _{TM} (8/20μS)	Type II MOV		

Note 1: The “Output Voltage Range” and “Output Frequency Range may differ according to the chosen grid standard.

MODEL NAME	PVI 25TL-208	PVI-36TL-480-V2	PVI 50TL-480	PVI 60TL-480
SYSTEM				
TOPOLOGY	Transformerless			
MAX. EFFICIENCY	97.0%	98.8%	98.8%	
CEC EFFICIENCY	96.5%	97.4%	98.5%	
STAND-BY / NIGHT CONSUMPTION	<3W			
ENVIRONMENT				
ENCLOSURE PROTECTION DEGREE	NEMA Type 4X			
COOLING METHOD	Variable speed cooling fans			
OPERATING TEMPERATURE RANGE	-22°F to +140°F / - 30°C to +60°C (derating from +113°F / +45°C)			
NON-OPERATING TEMPERATURE RANGE	No low temp minimum to +158°F / +70°C maximum			
OPERATING HUMIDITY	0-100%			
OPERATING ALTITUDE	13,123.4ft / 4000m (derating from 9842.5ft / 3000m)			
AUDIBLE NOISE EMISSION	<60dBA @ 1m and 25°C			
DISPLAY AND COMMUNICATION				
USER INTERFACE AND DISPLAY	LED, LCD			
INVERTER MONITORING	SunSpec, Modbus RS485			
SITE LEVEL MONITORING	Ethernet Network Card (1 per 32 inverters)			
MODBUS DATA MAPPING	Solectria Proprietary, Complies with SunSpec Modbus			
REMOTE DIAGNOSTICS / FW UPGRADE FUNCTIONS	Standard / with Ethernet Network Card			
MECHANICAL DATA				
DIMENSIONS (WXHxD)	39.4 x 23.6 x 10.24 in. (600×1000×260mm)			
WEIGHT	Inverter: 123.5 lbs (56kg); Wire-box: 33 lbs (15kg)			
MOUNTING / INSTALLATION ANGLE	15° to 90° from horizontal. 75° and below: shade cover required			
AC TERMINATION	M8 Stud Type Terminal Block (Wire range: #6-3/0AWG Cu/Al) Lugs not supplied			
DC TERMINATION	Screw Clamp, Neg. Busbar (RSD version) Wire range: #14 - #6AWG CU			
FUSED STRING INPUTS (5 PER MPPT)	20A standard fuse value (Fuse values up to 30A acceptable)			
SAFETY				
PV ARC-FAULT CIRCUIT PROTECTION	Type 1			
SAFETY AND EMC STANDARD	UL 1741-SB, UL 1741SA-2016, UL1699B, UL1998, CSA-C22.2 No. 107.1-01, FCC Part 15 (Subpart B, Class A)			
GRID STANDARD AND SRD	IEEE1547a-2014 / IEEE 1547-2018 (depending on firmware), Rule 21, ISO-NE			
SMART-GRID FEATURES	Volt-RideThru, Freq-RideThru, Ramp-Rate, Specified-PF, Volt-VAr, Freq-Watt, Volt-Watt, Watt-VAr			

11.2 Measurement Tolerances

The data supplied by the inverter may differ from measurements taken by certified measuring instruments (e.g. output meters, multimeters and grid analyzers). The inverter is not a measuring instrument and has wider tolerances for the measurements it makes.

Inverter tolerances are generally:

- $\pm 5\%$ for real-time measurements with output power below 20% nominal power
- $\pm 3\%$ for real-time measurements with output power above 20% nominal power
- $\pm 4\%$ for all statistical data

Yaskawa Solectria Solar PVI 25TL-208, PVI-36TL-480-V2, PVI 50TL-480, AND PVI 60TL-480 inverter tolerances are specified below:

- Voltage tolerances: $\pm 1\%$
- Current tolerances: $\pm 2\%$
- Frequency tolerances: $\pm 0.5\%$
- Power tolerances: $\pm 3\%$
- Time tolerances: $\pm 1\%$
- Temperature tolerances: $\pm 2^\circ\text{C}$

11.3 Production Graphs

The following sections illustrate the inverter production/derating in terms of DC voltage, ambient temperature, altitude and grid voltage.

11.3.1 DC Voltage Derating Graph

While the Solectria PVI 25TL-208, PVI-36TL-480-V2, PVI 50TL-480, and PVI 60TL-480 inverter has the ability to operate from 200-950 V_{dc} (Operating Voltage Range), it will only be able to output full rated power for its model from a limited Maximum Power Voltage Range for each model (see graphs). For example, for the 25TL the Maximum Power Voltage Range is 480-850Vdc. It is recommended to design the PV array so that the source circuits will have a V_{mp} that lies within the Maximum Power Voltage Range. If this is not possible, please refer to Figure 11-1, Figure 11-2, Figure 11-3, Figure 11-4 to see the effect of V_{mp} on output power.

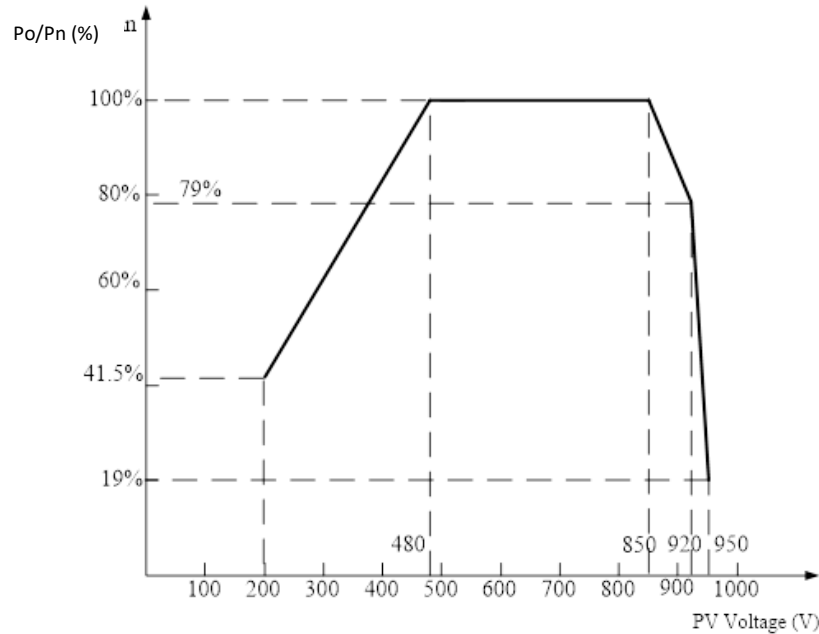

Figure 11-1 PVI 25TL-208 Derating with Respect to DC Voltage

Here's the derating graph for the PVI-36TL-480-V2:

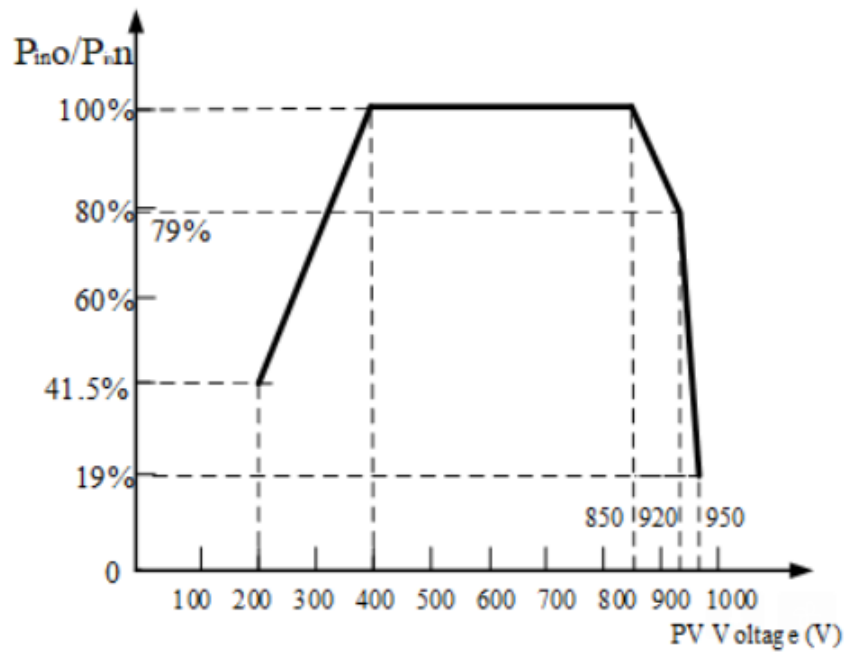

Figure 11-2 PVI-36TL-480-V2 Derating with Respect to DC Voltage

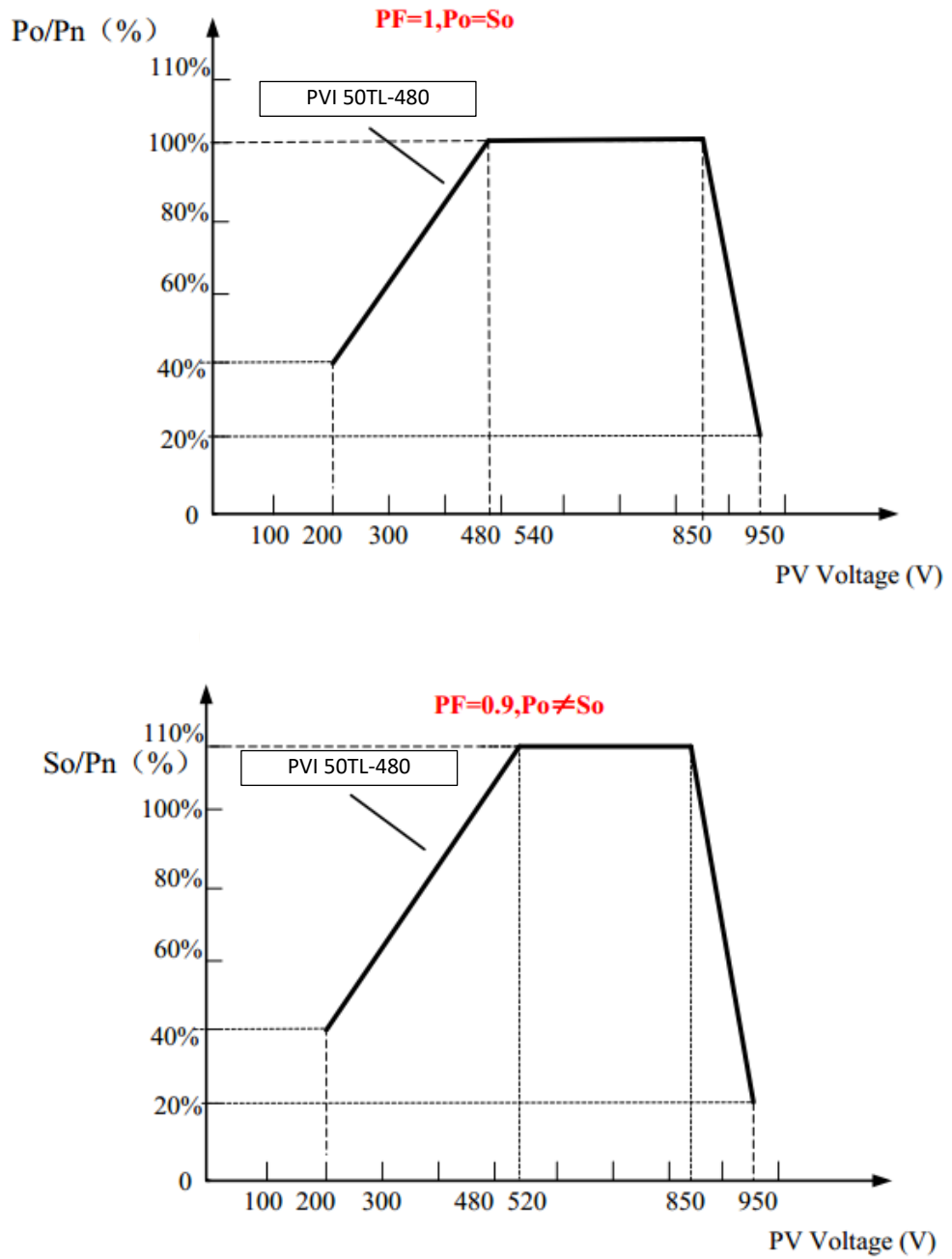
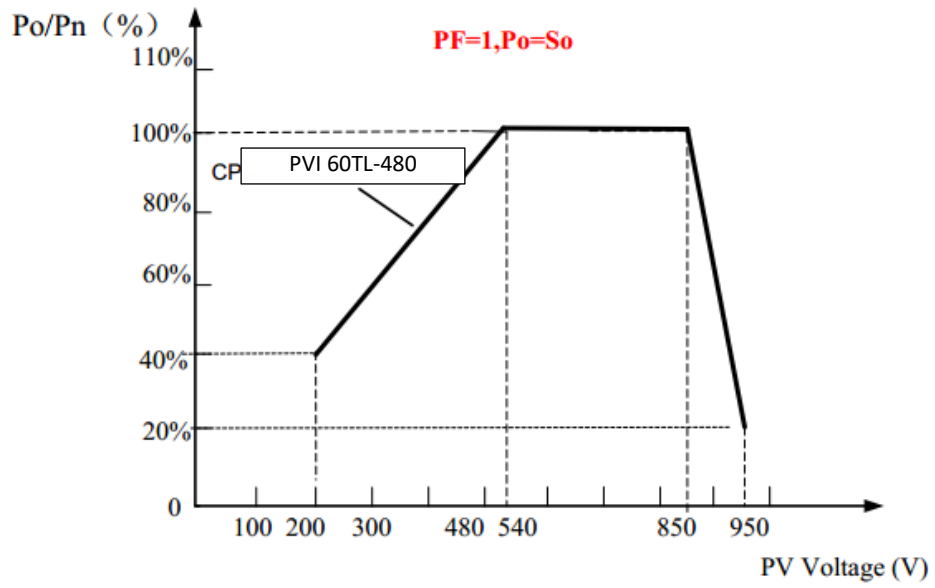

Figure 11-3 PVI 50TL-480 Derating with respect to DC Voltage



CI

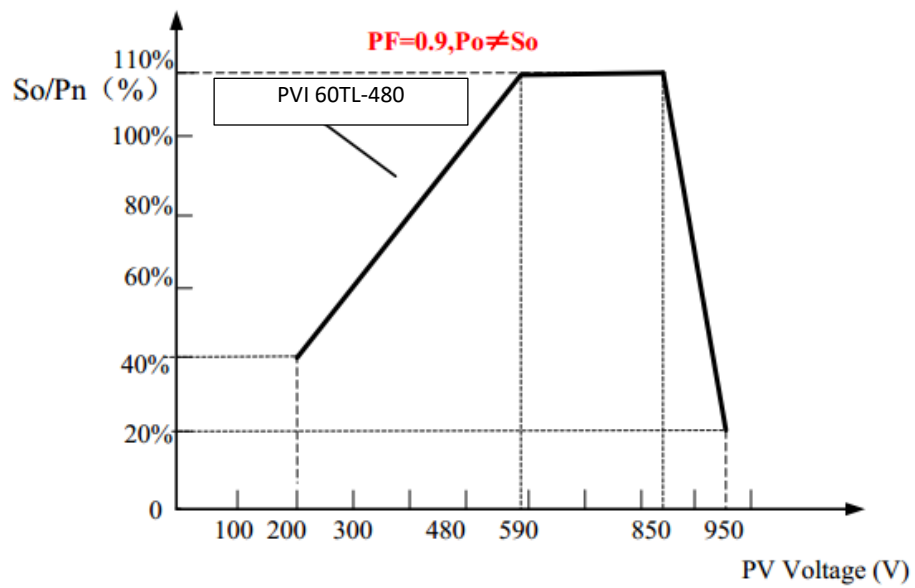

Figure 11-4 PVI 60TL-480 Derating with respect to DC Voltage

11.3.2 High Temperature Derating Graph

When the ambient temperature is higher than 113°F (45°C), the inverter output power (Pn) will begin to de-rate, as shown in **Error! Reference source not found..**

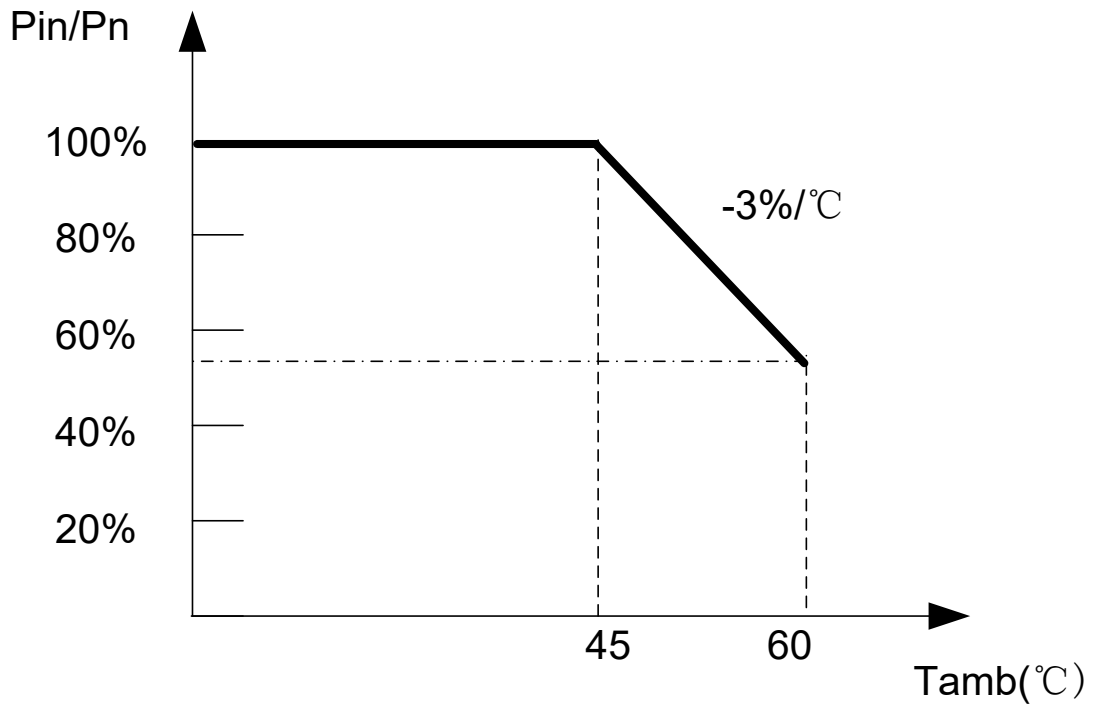

Figure 11-5 PVI 25TL-208, PVI-36TL-480-V2, PVI 50TL-480, AND PVI 60TL-480 Derating Curve with High Temperature

11.3.3 Altitude Derating Graph

When the altitude is higher than 9842.5ft (3000m), the rated output power (P_n) of the inverter will decrease, as shown in **Error! Reference source not found.**

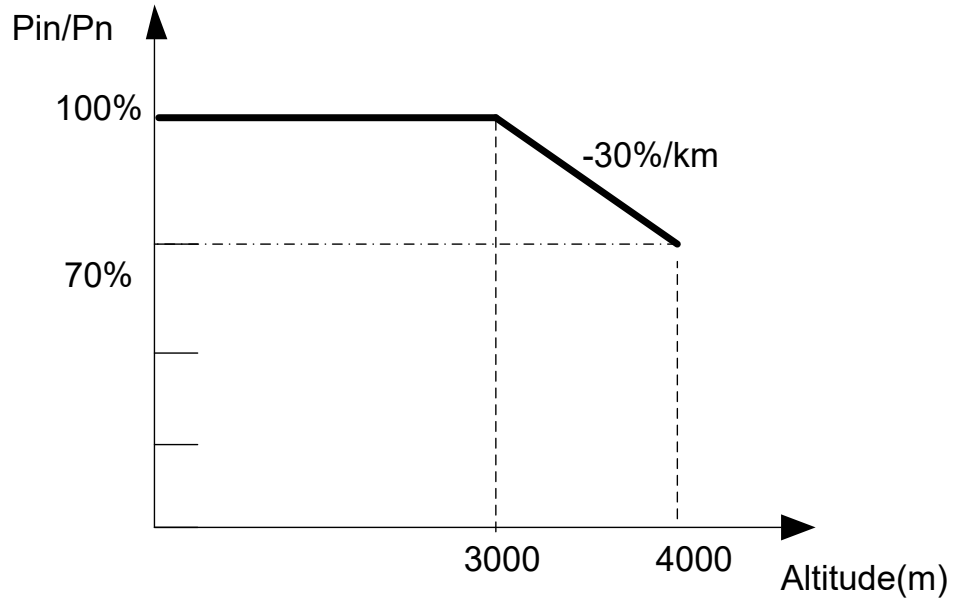

Figure 11-6 PVI 25TL-208, PVI-36TL-480-V2, PVI 50TL-480, AND PVI 60TL-480 Derating Curve with High Altitude

11.3.4 Grid Voltage Derating Graph

When the volt-watt function is disabled and the grid voltage is within 100% to ~110% (V_{nom} to $\sim 1.1 * V_{nom}$) of the Rated Output Voltage, the inverter output power (P_n) may reach 100%. When the grid voltage is lower than the Rated Output Voltage, the inverter will limit the AC Output Current and the output power (P_n) will begin to derate, as shown in **Error! Reference source not found..**

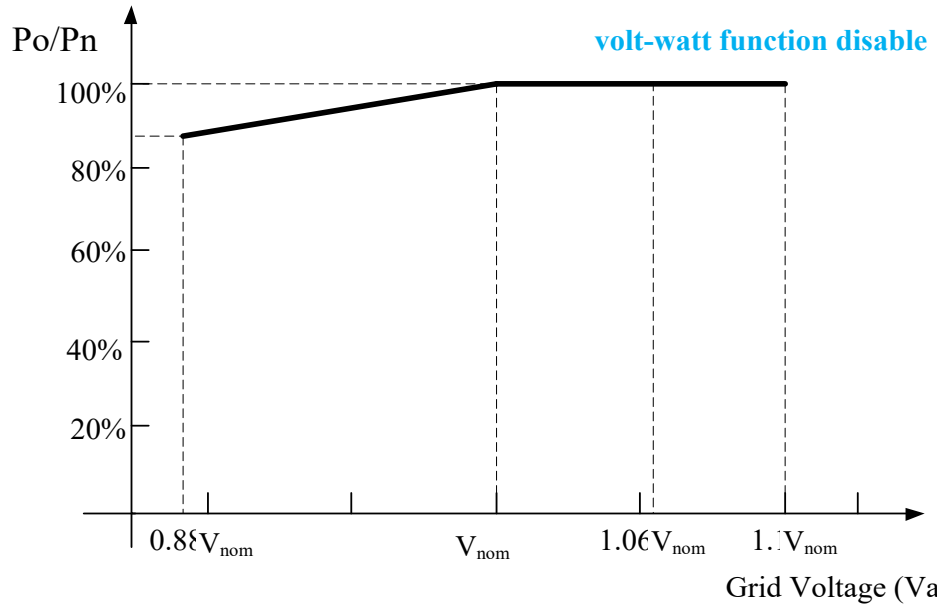

Figure 11-7 PVI 25TL-208, PVI-36TL-480-V2, PVI 50TL-480, AND PVI 60TL-480 Derating Curve in Respect to Grid Voltage without Volt-Watt

When the volt-watt function is enabled, the grid voltage is within 100%~106% ($V_{nom} \sim 1.06 * V_{nom}$) of the Rated Output Voltage, the inverter output power (P_n) may reach 100%. When the grid voltage is lower than the Rated Output Voltage or more than 106% V_{nom} , the inverter will limit the AC Output Current and the output power (P_n) will begin to derate, shown in Figure 10-3-2.

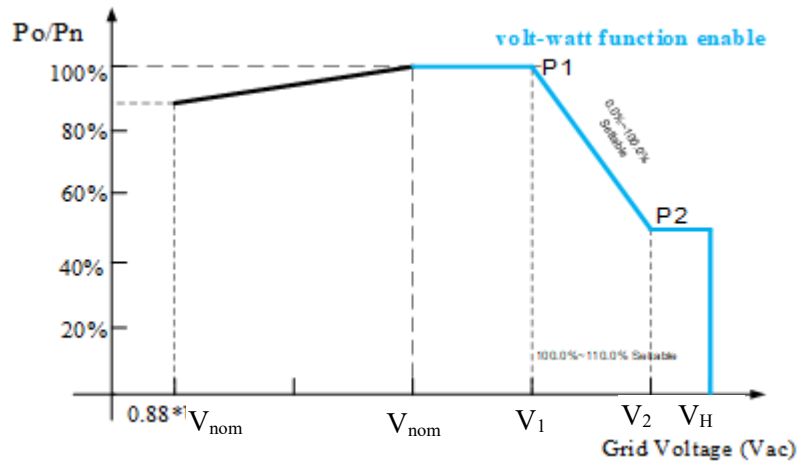

Figure 11-8 PVI 25TL-208, PVI-36TL-480-V2, PVI 50TL-480, AND PVI 60TL-480 Derating Curve of Grid Voltage with Volt-Watt

11.3.5 Reactive Power Capability

The Reactive Power Overload function is available for the PVI 50/60TL-480 and is disabled by factory default (Max. AC Apparent Power is 25/50/60kVA and Max. AC Output Current is 69.5A/60.2A/72.2A). For the PVI 25TL-208, only refer to the blue curve. Contact Yaskawa Solectria Solar Customer Service if you want to enable the Reactive Power Overload function.

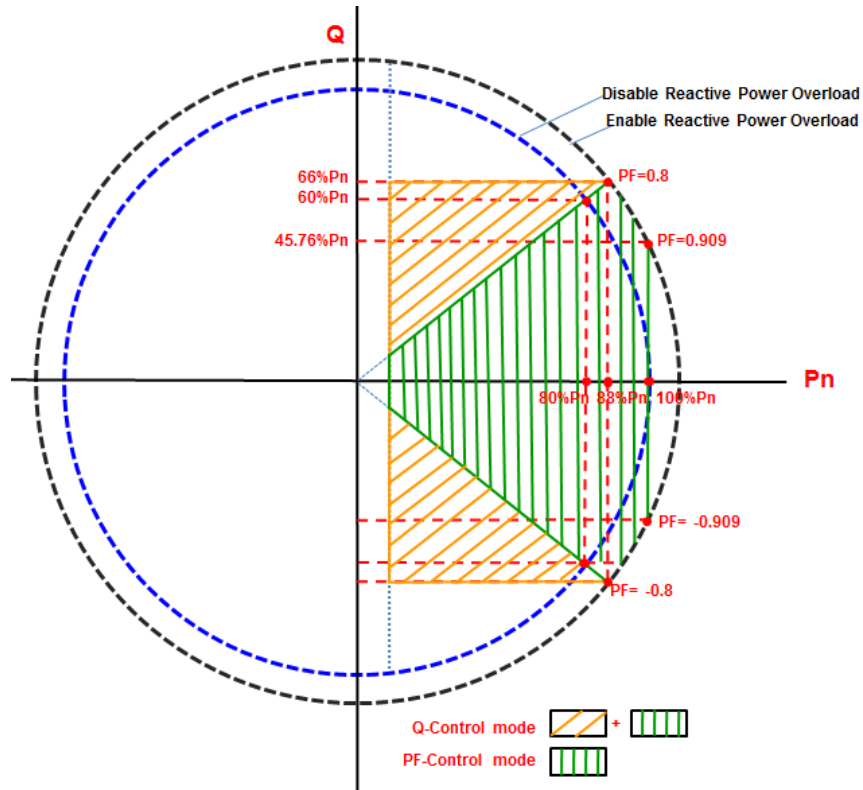

Figure 11-9 Reactive Power Capability

12. Appendix

12.1 Warranty and RMA Instructions

For all warranty information, please visit:

<http://solectria.com/support/documentation/warranty-information/grid-tied-inverter-warranty-letter/>

12.2 Datasheet

For the most up to date official datasheet, please visit www.solectria.com.

12.3 Contact Information

Telephone	978.683.9700
Technical Support & Service (After Sales Support)	978.683.9700 extension 2
Sales Support	sales@solectria.com
Website	www.solectria.com