

PVS-500 DC-COUPLED STORAGE SYSTEM

User's Manual

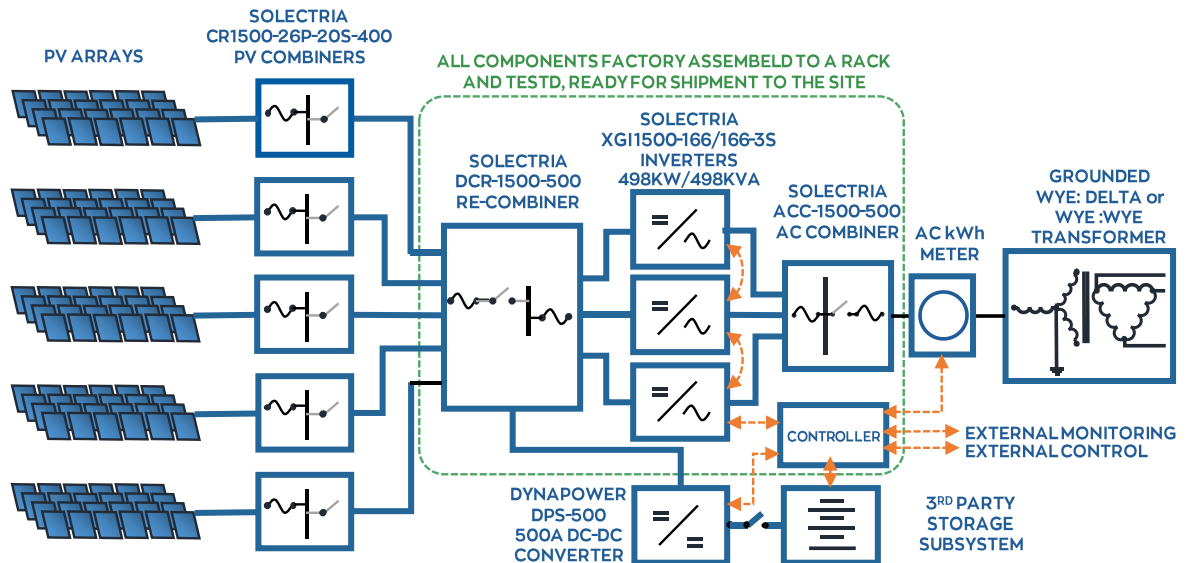

Contents

- 1. IMPORTANT SAFETY INSTRUCTIONS 3
- 2. SYSTEM OVERVIEW 4
- 3. INSTALLATION 5
 - 3.1 Delivery 5
 - 3.2 Placement and Anchoring..... 5
 - 3.3 AC Wiring 6
 - 3.4 DC Wiring 14
 - 3.5 Communications..... 23
- 4. System Operation 25
 - 4.1 Initial Commissioning Procedure 25
 - 4.2 System OFF Procedure 26
 - 4.3 System ON Procedure..... 26
 - 4.4 Replacement Fuses..... 27
- 5. WARRANTY & RMA INSTRUCTIONS..... 28
- 6. APPENDICES 28

1. IMPORTANT SAFETY INSTRUCTIONS

SAVE THESE INSTRUCTIONS

The SOLECTRIA **PVS 500 DC-Coupled Storage System** comprises a factory-integrated set of US-manufactured and factory-integrated components that form the core of the system: DCR-500 DC Re-Combiner, XGI 1500 Inverters, ACC-500 AC Combiner, and the Plant Master Controller. The storage system is complete with the addition five PV subarrays, five CR1500-400 PV Combiners, the Dynapower DC/DC Converter and the customer-selected battery system complete with enclosure, safety elements and controls. This DC-coupled Storage System's purpose is to couple the photovoltaic (PV) system and the storage system on a common DC bus behind the XGI 1500 inverters (see electrical diagram).

This manual provides instructions for operation of the PVS-500 DC Coupled Storage System. In addition, please read all instructions and warnings for the associated component equipment in their respective manuals.

This manual contains important instructions for operation of the PVS-500 DC-Coupled Storage System. To reduce the risk of electrical shock and to ensure the safe operation of the system, the following safety symbols are used to indicate dangerous conditions and important safety instructions.



WARNING
Could Injure
Personnel or
Damage Equipment



Instructions
for Qualified
Personnel Only



Positive
Connection
Point Symbol



Negative
Connection
Point Symbol



Ground
Connection
Point Symbol



DC Electrical
Connection
Point Symbol

3. SYSTEM OVERVIEW

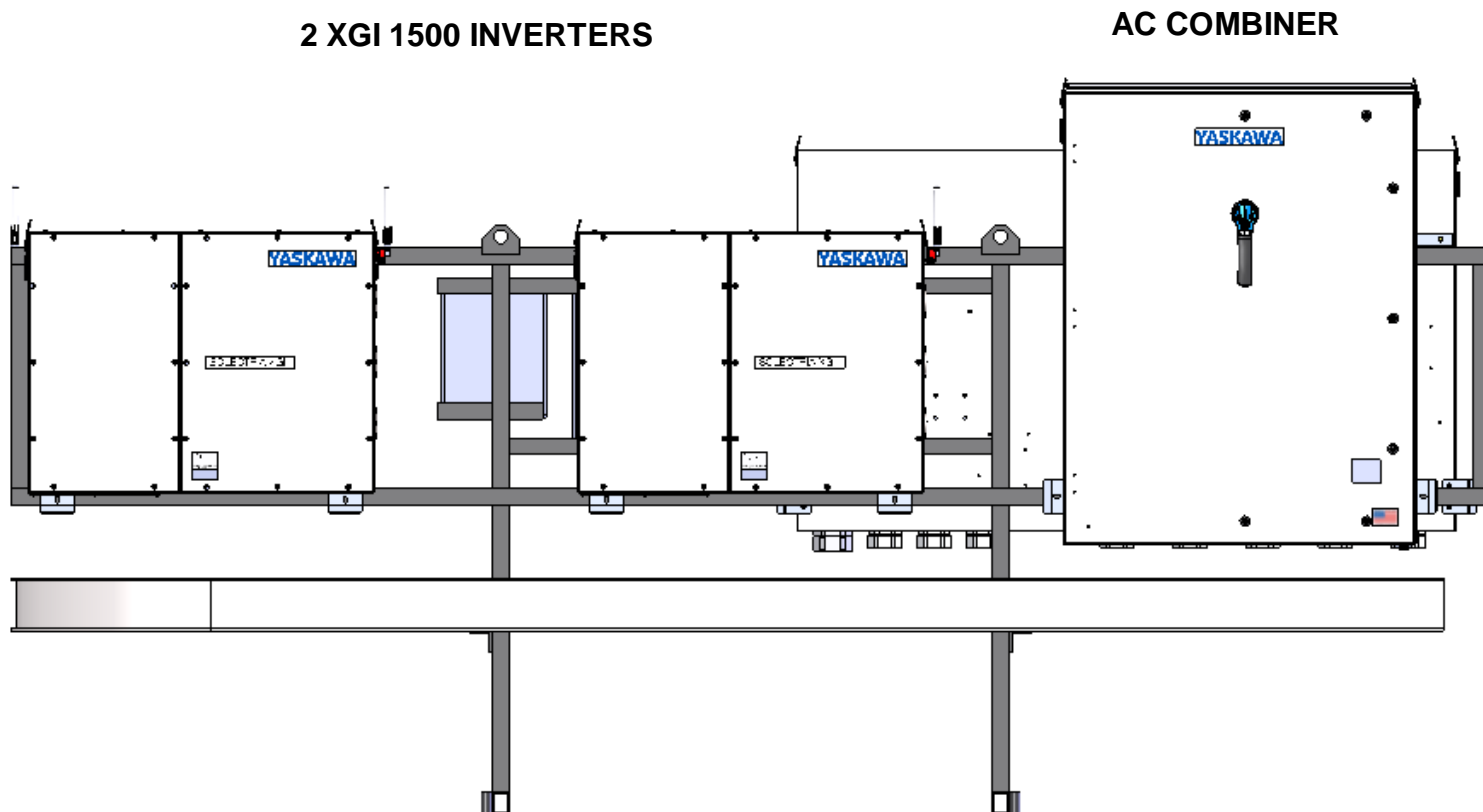
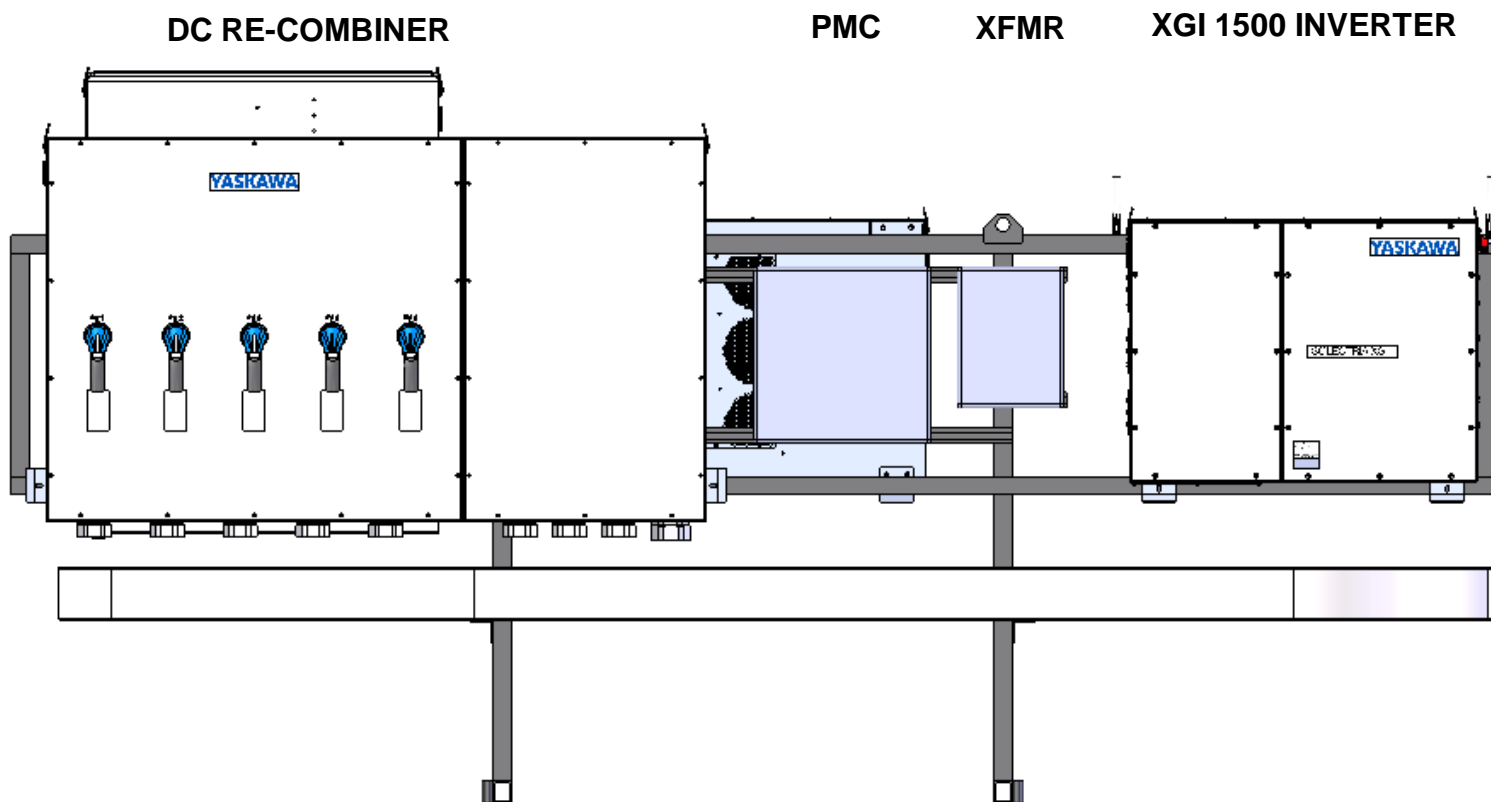

4. INSTALLATION

4.1 Delivery

The PVS-500 DC-Coupled Storage Rack weighs 3,000 pounds, and it's important to ensure that there is equipment on site capable of offloading the rack.

Check for Damage: Yaskawa Solectria Solar thoroughly inspects and rigorously tests all rack-mounted components in the PVS-500 DC-Coupled Storage System -- before shipment. On rare occasions damage may occur during shipping. Upon receipt of the PVS-500 system, check for the following:

- ✓ Inspect the AC Combiner as received, pre-mounted and pre-wired on the PVS-500 rack.
- ✓ If damage is observed, take digital photos to document the damage and immediately report the damage to the shipping company.
- ✓ If the recipient has any question about the potential shipping damage, contact Yaskawa Solectria Solar (see Section 6 for contact information).
- ✓ If Yaskawa Solectria Solar determines that the AC Combiner must be returned, obtain an RMA number from Yaskawa Solectria Solar and instructions for returning the unit.

4.2 Placement and Anchoring

To anchor the PVS-500 to a concrete pad, secure anchor bolts at each of the four anchoring provisions located at each end of the horizontal support waterbars. These anchor points have an internal diameter opening of 1". Follow NEC working clearances between racks.

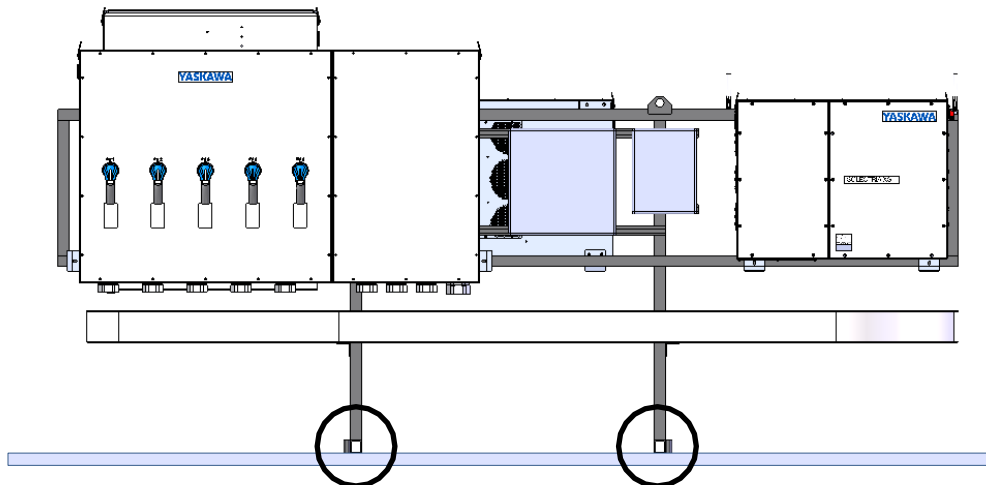

4.3 AC Wiring

All AC Wiring is completed within the ACC-1500-500 that is pre-mounted to the PVS-500 rack. The ACC1500-500 AC Combiner enclosure is rated Type 3R and will maintain this rating when the user follows appropriate installation methods.

STEP 1: Confirm that all wiring and associated components are de-energized

- ✓ Confirm that the AC switch on the AC Combiner is in the “Off” position.
- ✓ Confirm that the AC switch on the XGI 1500 inverters (on the rack with other equipment in the PVS-500 DC-Coupled Storage system) are in the “off” position (**Figure 4.1**).
- ✓ Confirm there is no voltage at the terminals for the XGI 1500 inverters’ AC output conductors in the ACC1500-500 AC Combiner.

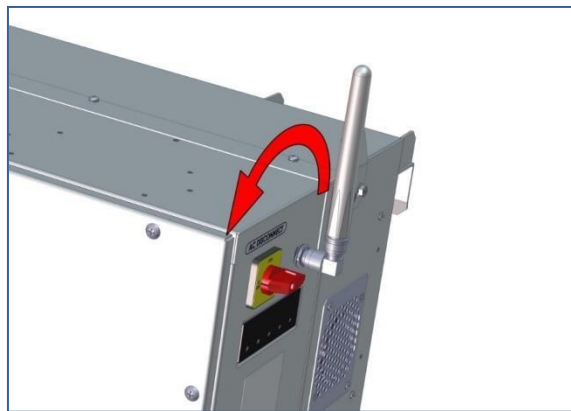

Figure 4.1 Rotate the XGI 1500 Inverter AC Disconnect to the “Off” position

STEP 2: Prepare the Enclosure for Conduits

- ✓ Note the target area for conduit connections for the combined AC Output Circuit, on the bottom face of the ACC1500-500 AC Combiner, as shown in **Figure 4.3**. Only the shaded areas indicated should be used.
- ✓ Add the holes for the conduit and fittings. The AC Combiner provides adequate space for 2” – 3” conduits for the 3-phase 600VAC conductors.
- ✓ Remove all metal shavings and debris from the inside of the AC Combiner.



Remove all metal shavings and debris from the inside of the ACC1500-500 AC Combiner enclosure.

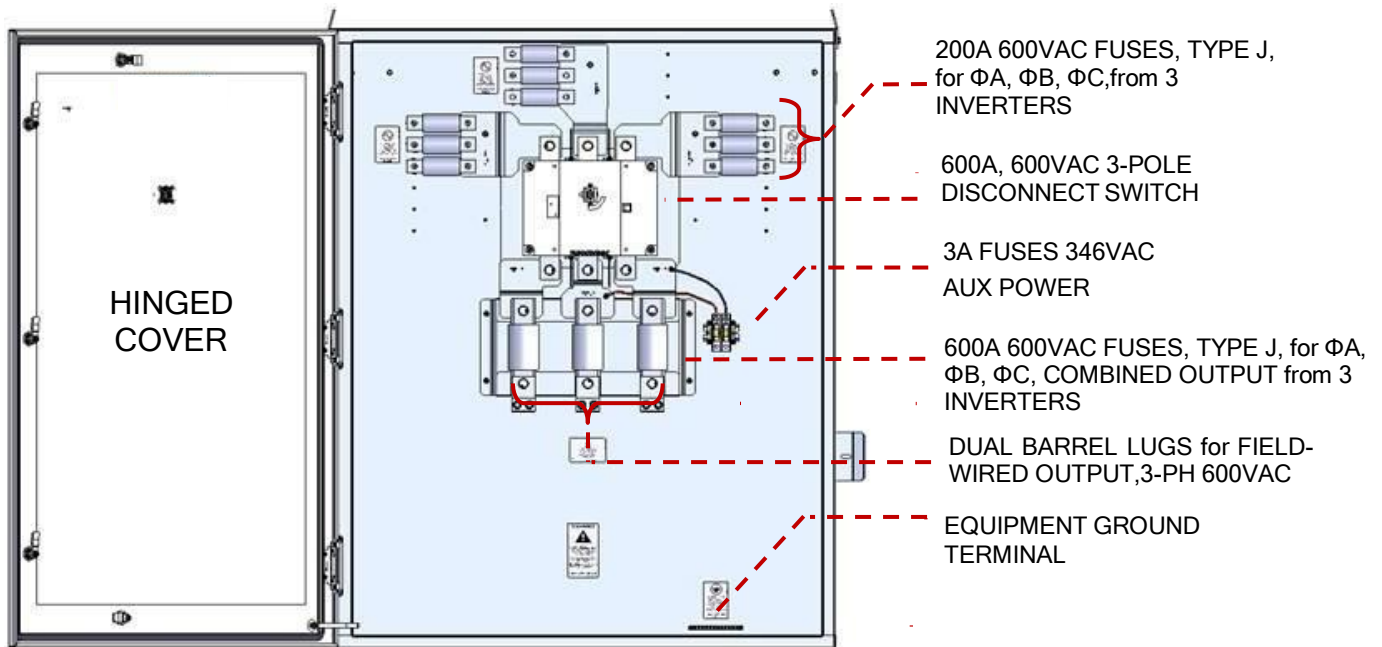

Figure 4.2 Interior of the ACC1500-500 AC Combiner

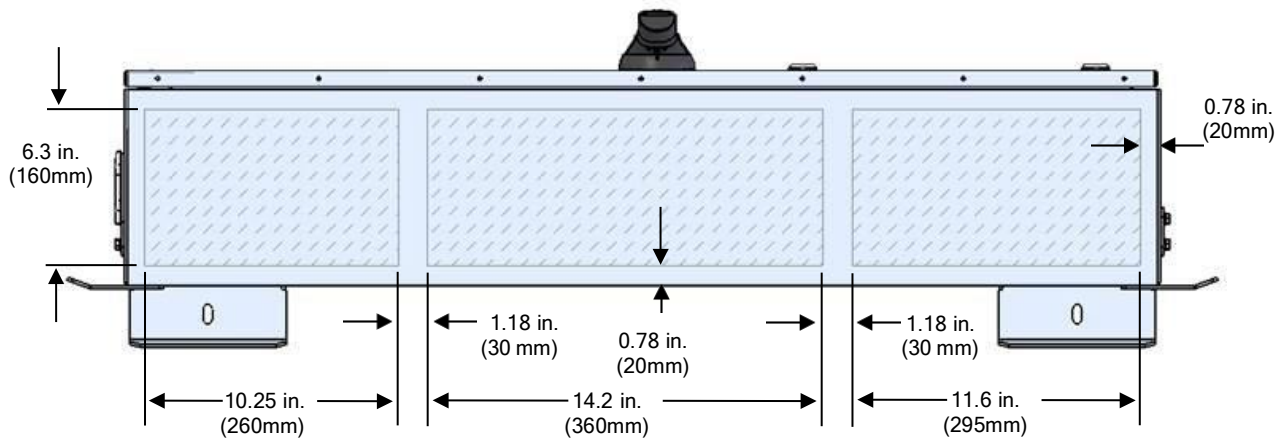

Figure 4.3 Bottom of the ACC1500-500 AC Combiner Showing Areas Available (shaded) for Conduit

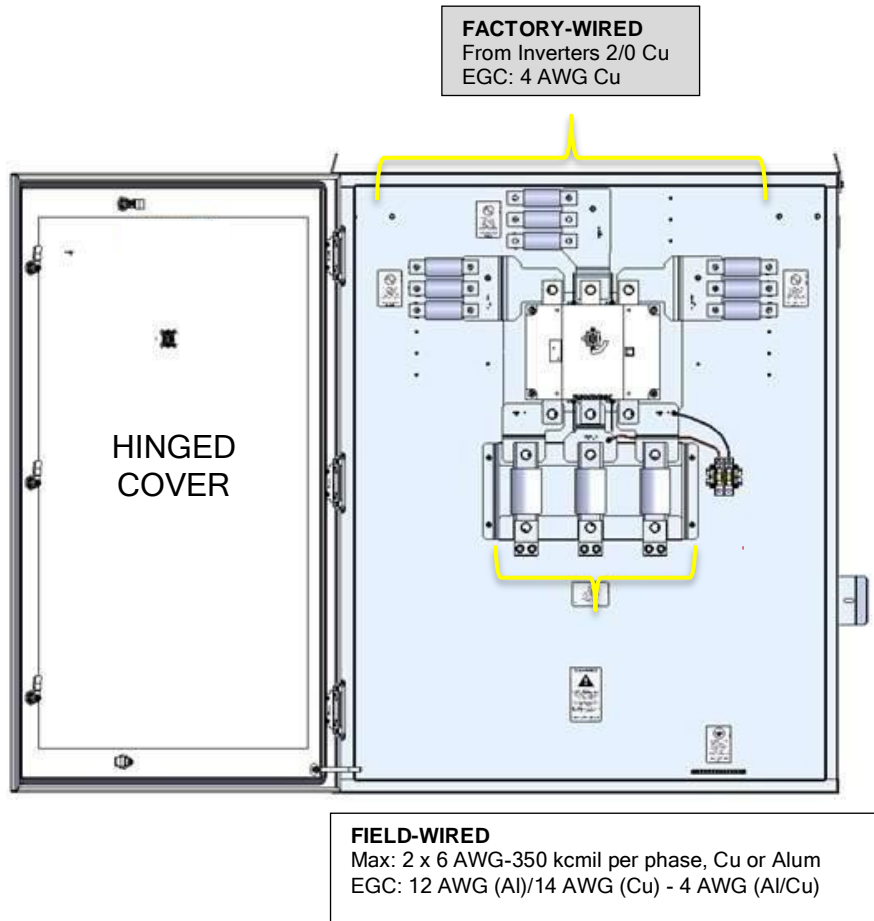

Figure 4.4 Specs for Field Wiring to the ACC1500-500 AC Combiner

Conduit Connections



Conduits connected to an outdoor enclosure can introduce water vapor into the enclosure and lead to the formation of condensation inside. Failure to follow these guidelines can result in water intrusion into the unit through the conduit connections and may void the warranty.

Follow these instructions and best practices when securing conduits to the ACC1500-500 AC Combiner.

1. Use UL514B certified water-tight conduit fittings and proper installation methods to provide a water-tight connection that will maintain the Type 3R rating of the enclosure.
2. Use an appropriately-rated sealant and seal the conduits fully to prevent the exchange of air between the conduit and the enclosure. Sealing the conduit will help prevent condensation in the enclosure.

WARNING



Condensation and Water Ingress Will Cause Damage: The DCR-1500-500 and Inverters are NEMA 4X, IEC IP66 rated. The ACC-1500-500 is rated Type 3R. If not properly installed, or if not properly maintained during extended periods of sitting idle (non-operating), all NEMA 4X, Type 3R, IEC IP66 enclosures are susceptible to water ingress and condensation that will damage critical components.

IMPORTANT: After sealing the conduit entrances, the risk of condensation increases when the system is inoperative for an extended period of time. ESS sites are often sit idle for an extended period between the initial installation and the commencement of normal, autonomous daily operation. Follow these guidelines:

Manage Moisture During Extended Down-Time (non-operating system for more than 1 week)

- Extended periods of down-time can occur, for example, if turn-on/start-up is delayed more than one week following initial installation, or if the inverter is idle for more than a week during a service event. For any reason, if a system will be idle for longer than one week without power, install a desiccant pack inside the DCR, ACC and inverters.
- For long idle periods, visit the equipment at least once per month to inspect the desiccant, remove all moisture inside the equipment, and replace the desiccant pack as necessary.
- Before turn-on/start-up following a period of down-time, inspect the equipment, remove all moisture inside the enclosure, and remove the desiccant pack and any debris.
- Desiccant packs are only intended to protect the equipment from moisture during periods of down-time, and *should not be left inside an operating system*.
- Do not let system be idle for longer than 6 months. If left idle for more than 6 months a Yaskawa Solectria Technician will need to inspect equipment prior to energization.

Recommended Desiccant
Dry & Dry 500gram
SPECIAL Orange Indicating
Packets
www.dryndry.com



Figure 4.5 Desiccant Pack

WATER INGRESS WILL VOID WARRANTY: It is the responsibility of the installer to maintain a dry, moisture-free DCR enclosure; water ingress is not covered under warranty.

STEP 3: AC Output Circuit Connections



Do not attempt to make connections to the ACC1500-500 AC Combiner if not qualified for electrical work.

See NEC Articles 310 and 690 for proper conductor sizing. The phase lugs are shown in **Figure 4.6** and their specifications in **Table 4.1**.

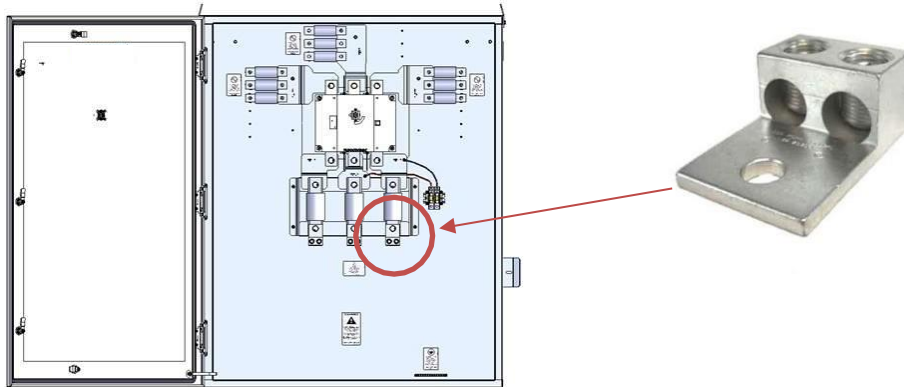

Figure 4.6 Phase Lugs (one per phase)

Table 4.1 Phase Lug Specifications

Phase Lugs Specifications	
Conductor Compatibility	6AWG - 350kcmil Copper and Aluminum
Conductor Type	2-Barrel
Temperature Rating	90C
Torque	350kcmil to > 2 AWG: 375 in-lb 6 AWG to ≤ 2 AWG: 275 in-lb

Follow these steps when making conductor connections in the AC Combiner:

- ✓ Verify absence of voltage on all conductors.
- ✓ Run the AC Output Circuit conductors into the AC Combiner through appropriate conduit and fittings.
- ✓ Connect the phase conductors to the lugs and apply torque per the specifications in **Table 4.1**
- ✓ Connect equipment ground conductors to the equipment ground terminals.

Aluminum Conductors



Aluminum oxidizes quickly when exposed to the atmosphere. An oxidized layer is a poor conductor that could lead to thermal issues, production loss, or damage to the Re-Combiner.

When using aluminum conductors, follow these steps to prepare the conductors.

1. Prepare one wire at a time.
2. Remove the appropriate insulation from the wire.
3. Using a wire brush, remove the oxidized outer layer from the aluminum conductors.
4. Immediately apply a neutral dielectric grease, such as Ideal NOALOX® anti-oxidant compound, and connect the aluminum cable to the terminal.
5. If the connection is not made within 30 seconds of applying the compound, repeat this process, as an oxidized layer may have formed on the conductor.

STEP 4: Equipment Ground Wire Connections

Terminals are provided in the Combiner for all Equipment Grounding Conductors (EGCs). Torque each EGC per the specifications in **Table 4.2** below.

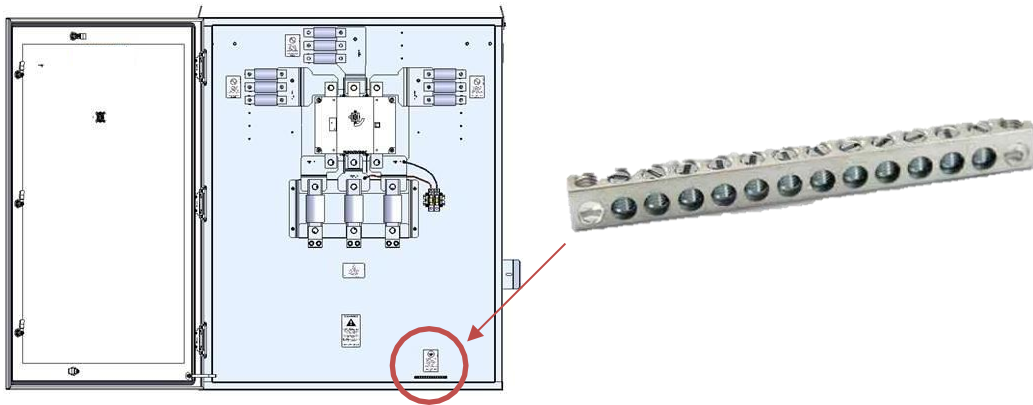



Figure 4.7 Equipment Ground Bar

Table 4.2 Ground Bar Specifications

Ground Bar Specifications	
Positions	12 
Conductor Compatibility	12 (Al) / 14 (Cu) AWG - 4 AWG
Temperature Rating	90C
Torque	20 in-lb, flat-head screwdriver

Final Steps



Verify the proper polarity of each conductor. Polarity reversal can lead to dangerous conditions capable of harming personnel and damaging equipment.



Check the AC Combiner for tools and debris; ensure that the unit is clean and orderly.

- ✓ Verify that all connections meet the requirements of this User's Manual.
- ✓ Secure the ACC1500-500 AC Combiner cover, ensuring that all ¼-turn fasteners are secured.
- ✓ Consult the startup and commissioning procedures for the PVS-500 DC-Coupled Energy Storage system before energizing.



Do not operate the disconnect handle switch with the AC Combiner door open.

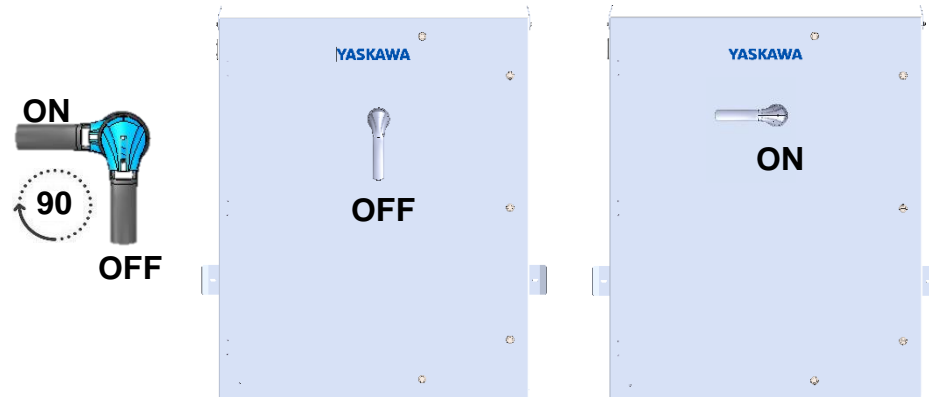

Figure 4.8 Switch Handle Positions for OFF (left) and ON (right)

The ACC1500-500 AC Combiner contains a user-operable AC disconnect switch. When this disconnect switch handle is in the OFF position, the circuit is open between the input Inverter AC Output Circuit conductors and the combined AC Output Circuit conductors. The disconnect handle can be locked in the OFF position with user supplied safety locks. The plastic tab on the face of the disconnect handle can be lifted to reveal the locking provisions.

The disconnect switch is rated for 600A, is fully load-break rated and can be safely operated under normal operating conditions when installation is per this User’s Manual and all warnings and ratings are observed.

3.4 DC Wiring

All DC wiring is completed within the DCR-1500 Re-Combiner. The DCR-1500 Re-Combiner functions as the DC bus in the SOLECTRIA PVS-500 DC-Coupled Energy Storage System, coupling 5 PV inputs, 3 Inverter inputs, and one DC/DC converter input. The DCR-1500 Re-Combiner provides overcurrent protection for the PV and DC/DC Converters and also ground fault sensing for the PV inputs.



WARNING: Disconnect all PV modules or completely cover the surface of all PV modules with opaque (dark) material before wiring. PV arrays produce dc voltage when exposed to light and could create a hazardous condition. Always verify the absence of voltage before performing work on the Re-Combiner.



WARNING: Connecting PV output circuits to the input of the Re-Combiner and making the connection to the Dynapower DC/DC Converter (DPS-500 or DPS-375) and battery subsystem, must only be done after receiving approval from the utility company and AHJ, and should only be performed by qualified persons.

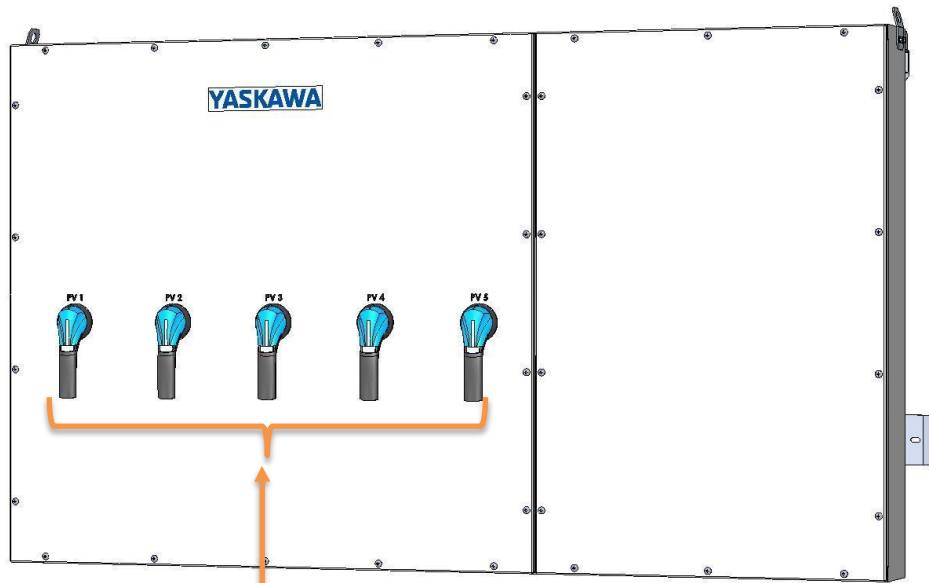

400A DC DISCONNECT SWITCHES FOR PV OUTPUT CIRCUITS

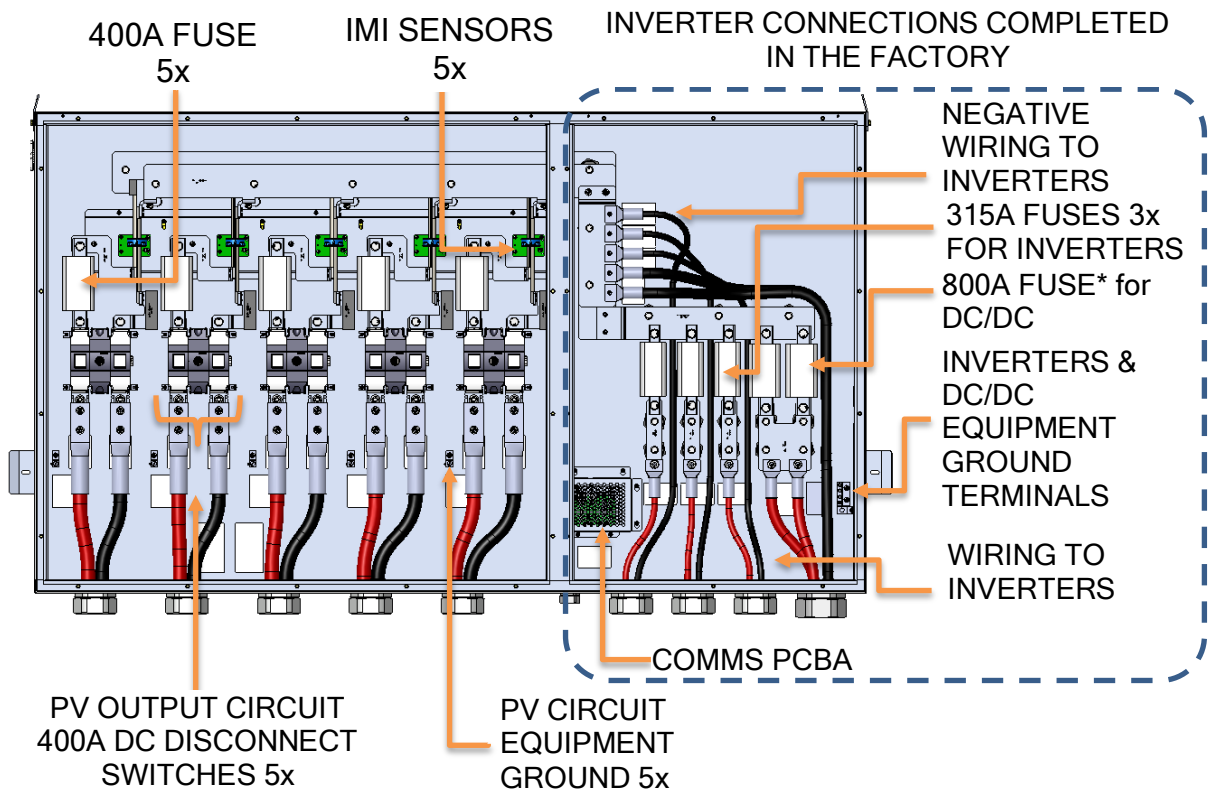

Figure 4.9 The DCR-1500 DC Re-Combiner Components

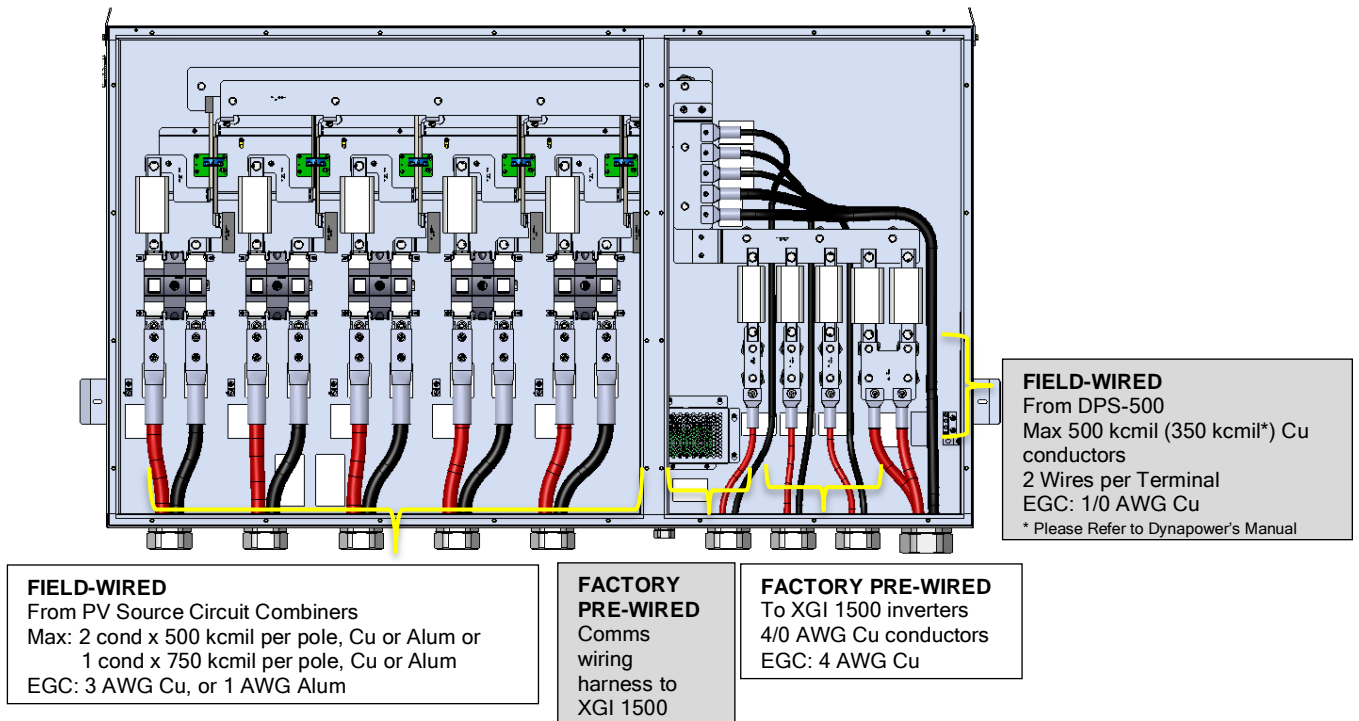

Figure 4.10 – Specs for Field Wiring to the DCR-1500 Re-Combiner

STEP 1: Disconnect all Equipment Before Wiring to the Re-Combiner

BEFORE removing the Re-Combiner's covers:



- ✓ Open all five DC switches on the Re-Combiner, and
- ✓ Open the DC switch between the Dynapower DC/DC Converter and the Battery Subsystem, to disconnect the batteries from the system.

STEP 2: De-Energize the PV Conductors



PV arrays can create hazardous DC voltages. Do not attempt to connect the PV circuits to the Re-Combiner until all PV conductors are confirmed to be de-energized.

1. Use a multi-meter to check for DC voltage and confirm that the PV Output Circuit conductors, coming from the CR1500-26-20S-400 PV Source Circuit Combiners in the array field, are de-energized.
2. If DC voltage is present, locate the PV Source Circuit Combiners and open all DC disconnect switches, then re-measure.
3. DO NOT PROCEED until the conductors are confirmed to be de-energized.

STEP 3: Prepare the Enclosure for Conduits

1. Remove the left-side cover from the Re-Combiner; save all fasteners for later re-installation.
2. Note the target area for conduit connections for the PV circuits on the bottom face of the Re-Combiner, as shown in **Figure 4.11**.
3. Add the necessary holes for the conduits for PV Output Circuit entries. The Re-Combiner accepts up to 5 separate PV Output Circuits.
4. Be sure to remove any metal shavings and debris from the inside of the Re-Combiner.

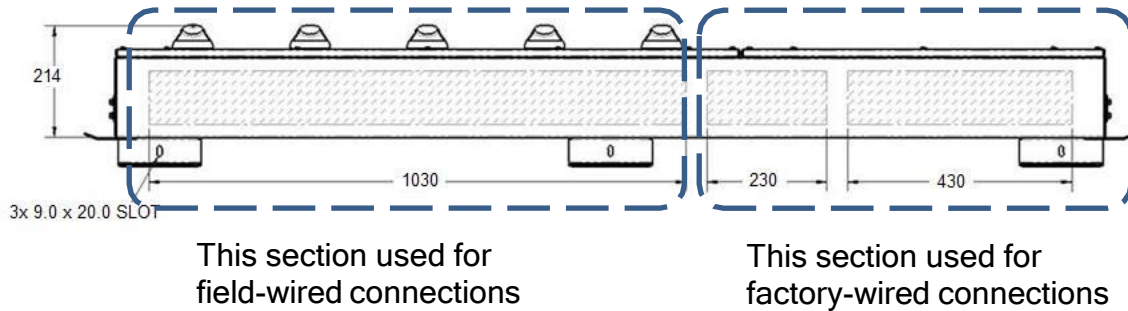

Figure 4.11 Re-Combiner Conduit Entry Locations

SPECIAL INSTRUCTIONS

PRECAUTIONS FOR ALUMINUM WIRE AND CONDUIT SEALING

Aluminum Conductors



Aluminum oxidizes quickly when exposed to the atmosphere. An oxidized layer is a poor conductor that could lead to thermal issues, production loss, or damage to the Re-Combiner.

When using aluminum conductors, follow these steps to prepare the conductors.

1. Prepare one wire at a time.
2. Remove the appropriate insulation from the wire.
3. Using a wire brush, remove the oxidized outer layer from the aluminum conductors.
4. Immediately apply a neutral dielectric grease, such as Ideal NOALOX® anti-oxidant compound, and connect the aluminum cable to the terminal.
5. If the connection is not made within 30 seconds of applying the compound, repeat this process, as an oxidized layer may have formed on the conductor.

Conduit Connections



Conduits connected to an outdoor enclosure can introduce water vapor into the enclosure and lead to the formation of condensation inside. Failure to follow these guidelines can result in water intrusion into the unit through the conduit connections and may void the warranty.

Follow these instructions and best practices when securing conduits to the Re-Combiner.

1. Use UL514B certified water-tight conduit fittings and proper installation methods to provide a water-tight connection that will maintain the Type 3R rating of the enclosure.
2. Use an appropriately-rated sealant and seal the conduits fully to prevent the exchange of air between the conduit and the enclosure. Sealing the conduit will help prevent condensation in the enclosure.

STEP 4: PV Output Circuit Wiring Terminations in the Re-Combiner

The PV Output Circuit conductors terminate on tabs extending from the DC switch. The tabs are factory-supplied with dual studs to maintain conductor alignment. **Figure 4.12** illustrates the terminations and the sections below identify the relevant specifications. Note that users must supply the Crimp Lug and Fasteners as defined.

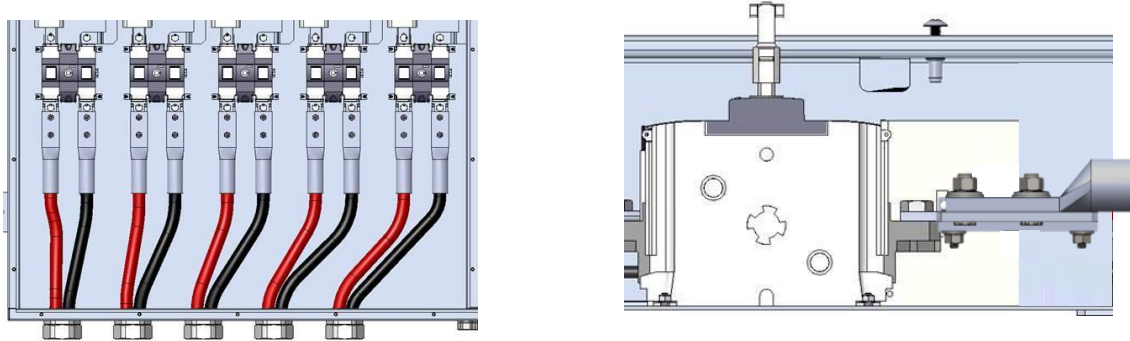
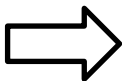

Figure 4.12 PV Output Circuit Conductors Terminations



Positive polarity conductors (red wires in **Figure 4.12**) connect to a fuse. Confirm polarity and fuse connection for positive conductors.

Lugs Compression lugs are NOT provided with the Re-Combiner. The lugs must conform to the specifications given in the table below:

Lug Type	Plating & Material	Max. Tongue Width	Hole Size	Temp Rating
Two-Hole	Tin Plated Cu	1.95 in	for M8 stud	90C
Max distance from hole center to end of lug			14 mm	

Conductors

Max Allowable Conductor Size	Cu or Alum, 90C temp rating 1 or 2 cond at 500 kcmil 1 cond at 750 kcmil
-------------------------------------	--

Conductor Termination

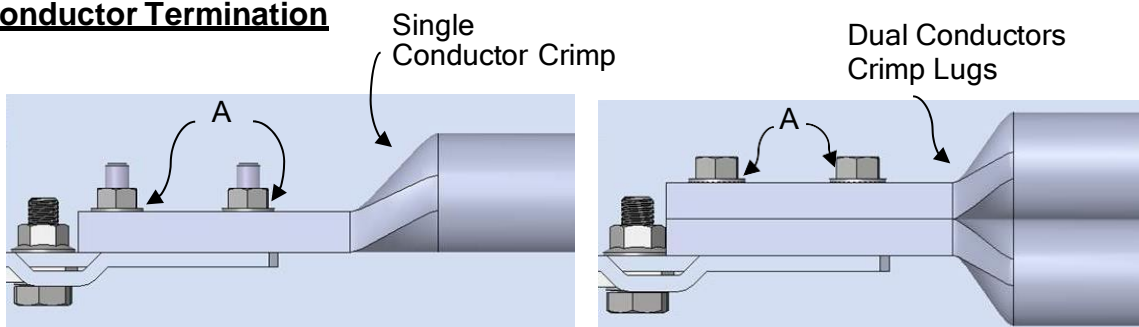

Fasteners <i>(Supplied)</i>	A: 8mm flanged nut, SS Torque: 90 in-lb (10 Nm)
---------------------------------------	--

Figure 4.13 Single and Dual Conductor Terminations

STEP 5: Dynapower DC/DC Converter Conductor Termination

The user is responsible to source, route, secure and properly terminate conductors from the DCR to the Dynapower DC/DC Converter.

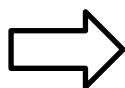

See the Dynapower DC/DC Converter Installation User Manual for making connections to that unit.

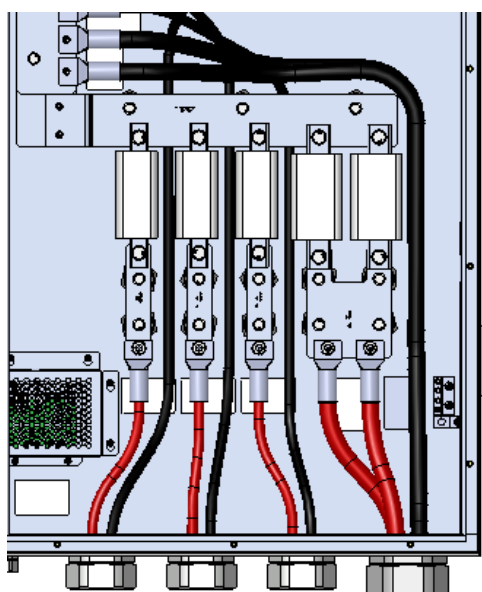

Conductors

Max Output Current	DPS-500: 500 A
DC Re- Combiner No. of Terminals	2 Pos , 2 Neg Terminals (2 Wires per Terminal)
Terminals	Negative: 2 x 8mm Stud 40mm wide plate Positive: 2 x 10mm Stud 35mm wide plate
Max Conductor Recommendation	500 kcmil (350 kcmil*), 90C rated 2 Wires per Terminal <small>* Please Refer to Dynapower's Manual</small>

Figure 4.14 Dynapower DC/DC Converter Terminations inside the Re-Combiner



WARNING: Connecting any components other than the Dynapower DC/DC Converter (models DPS-500 or DPS-375) to the PVS-500 will result in voiding the warranty (including DCR, ACC and Inverters).

STEP 6: Equipment Ground Wiring

Terminals are provided in the Re-Combiner for all Equipment Grounding Conductors (EGCs) associated with the PV Source Circuits, Dynapower DC/DC Converter and XGI 1500 inverters. NOTE: the Re-Combiner comes from the factory with the XGI 1500 inverters and Dynapower DC/DC Converter Equipment Ground Conductors pre-wired to ground lugs. Torque each EGC for the PV Source Circuits per the specifications below.

PV Equipment Ground Lugs (5x)

14 AWG - 2 AWG Torque to 20 in-lb, Slotted Screw Cu or Al Conductors

Final Steps



Verify the proper polarity of each conductor. Polarity reversal can lead to dangerous conditions capable of harming personnel and equipment.



Check the Re-Combiner for tools and debris; ensure that the unit is clean and orderly.

1. Verify that all connections meet the requirements of this User's Manual.
2. Secure the Re-Combiner cover, ensuring that all fasteners are in place.
3. Consult the startup and commissioning procedures for the PVS-500 before energizing.

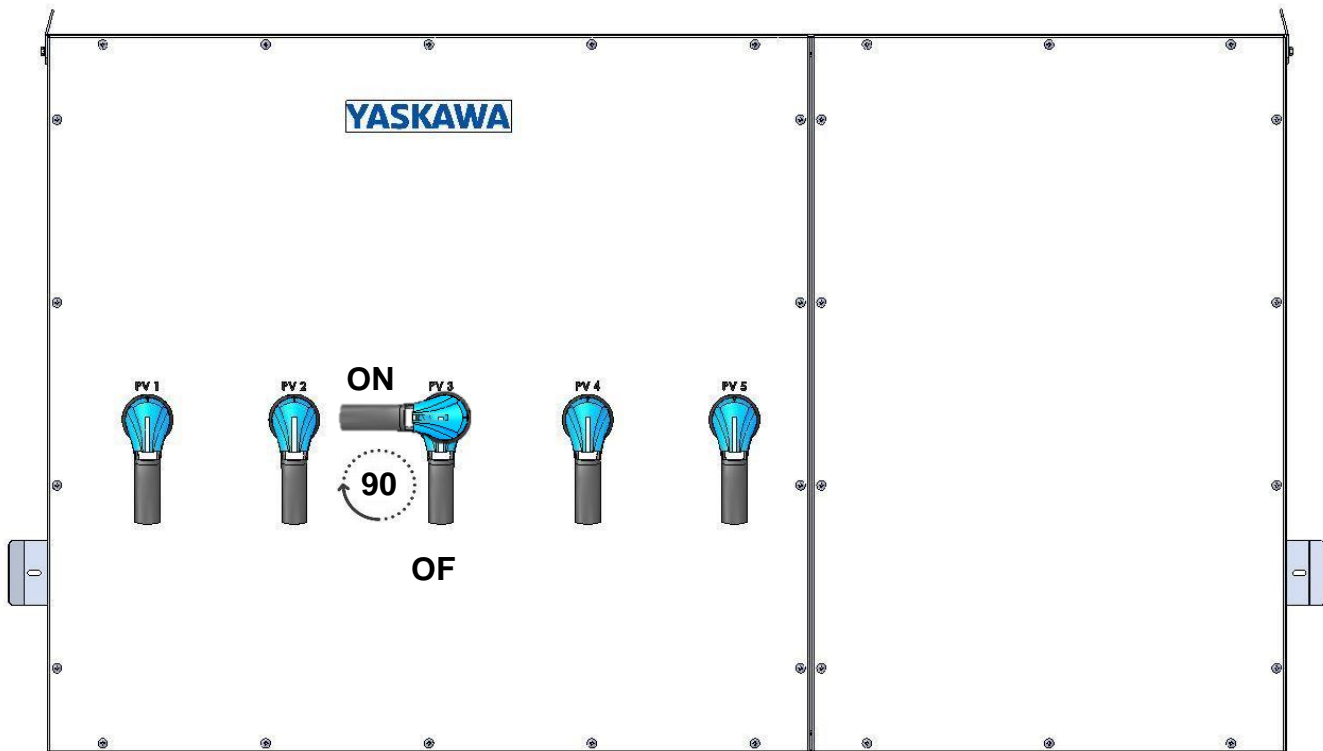

Figure 4.15 Re-Combiner Switches On/Off Positions

The Re-Combiner contains five user-operable disconnect switches for the PV Output Circuit inputs (see **Figure 4.15**). When the disconnect switch handle is in the OFF position, the circuit is open between the PV Output Circuit and the DC bus in the Re-Combiner. Conversely, when the disconnect switch is in the ON position, the circuit is closed between the PV Output Circuit and the DC Bus in the Re-Combiner.

The disconnect switch is rated for 400A, is fully load-break rated and can be safely operated under normal operating conditions when installation is per this User's Manual and all warnings and ratings are observed.

➡ All Disconnect Switches must be OFF before working on the Re-Combiner.

3.5 Communications

The inverter MODBUS TCP network and Heila Edge controller are prewired to the network switch inside the Heila control cabinet. Install two separate Cat 6 Ethernet cables with internet access to the network switch inside this cabinet.

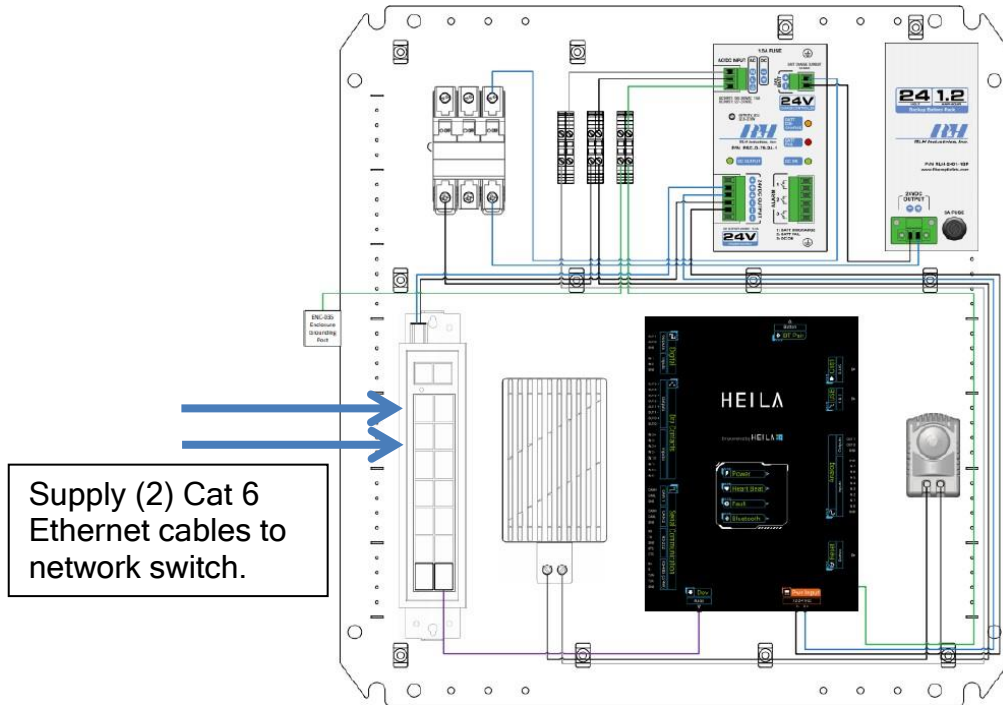

Figure 4.16 Heila Control Cabinet Components

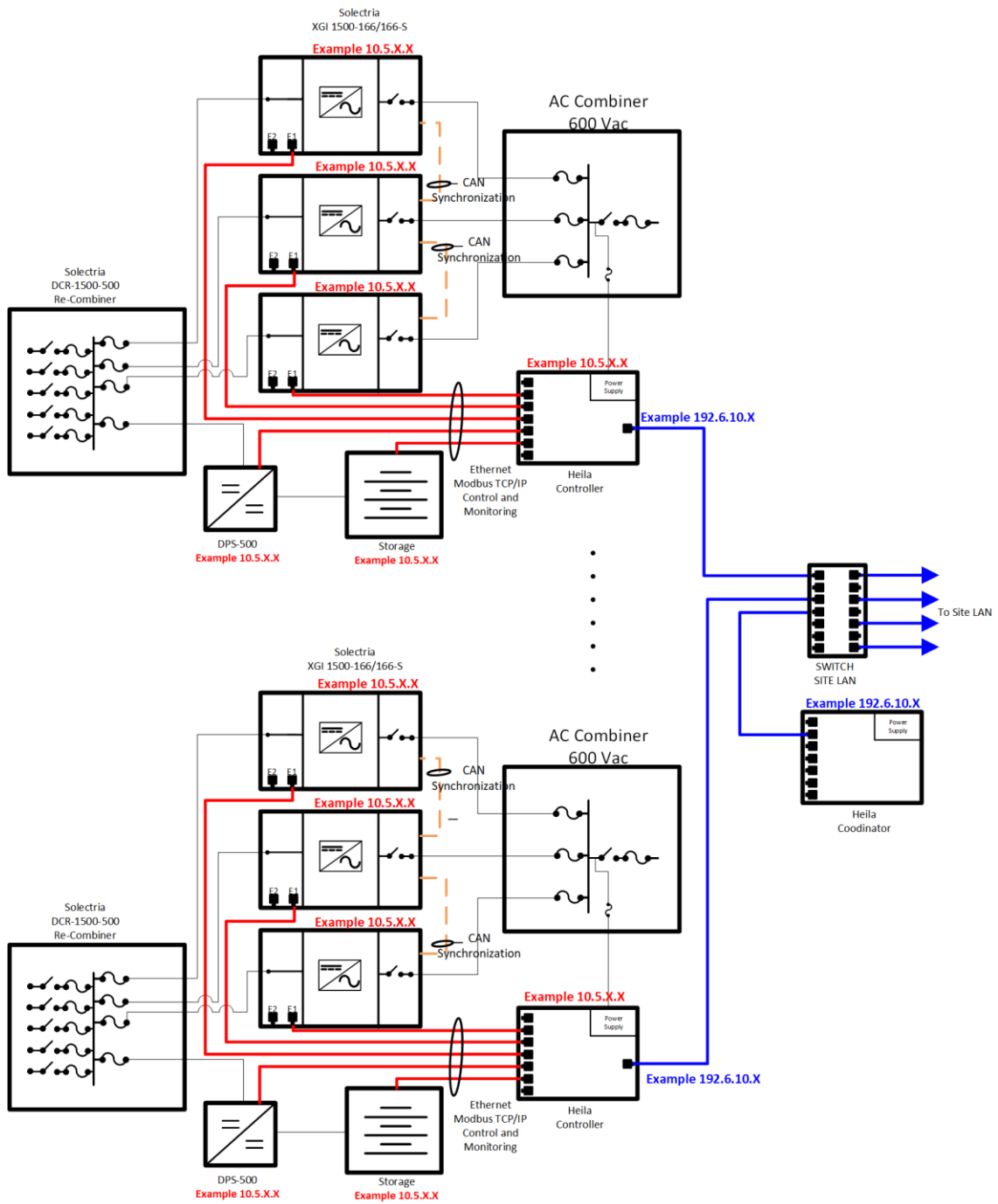

Figure 4.17 PVS-500 Communications Scheme

4. System Operation

Following the installation of all equipment and confirmation of all connections and terminations, system commissioning should commence.

4.1 Initial Commissioning Procedure

- Turn OFF and lock out all PV Combiner Boxes
- Turn OFF and lock out AC source to AC Combiner
- Turn OFF and lock out battery source
- Turn OFF all three of the XGI-1500 red on/off switches on the right side of an inverter.
- Press the DPS 500 emergency OFF (EPO) button on the front panel of the converter.
- Turn the disconnect handle on the AC combiner to the OFF position
- Turn OFF all 5 DC disconnect switches on the front of the DC Recombiner (DCR)
- Turn OFF the DC disconnect switches between DCR and the batteries.
- Remove DC Recombiner cover and verify absence of voltage from all sources
- Verify all cabling in the DC Recombiner is installed correctly and torqued appropriately
- Replace DC Recombiner cover
- Remove AC Recombiner cover and verify absence of voltage from all sources
- Verify all cabling in the AC Combiner is installed correctly and torqued appropriately
- Replace DC combiner cover
- Close all PV source circuit fuse holders in the combiner boxes and close the cover.
- Energize the Battery
- Turn ON source of power to the AC combiner
- Turn the DC disconnect switches between the DCR and the batteries to the ON position.
- At each combiner, turn the DC disconnect to the ON position.
- Turn ON all 5 DC disconnect switches on the front of the DC Recombiner
- Turn the disconnect handle on the AC combiner to the ON position
- Release the DPS 500 emergency off (EPO) button on the front panel of the converter.
- Turn ON all three of the XGI-1500 red on/off switches on the right side of an inverter.
- Logon to the network and confirm network access to inverters and Heila controller.

4.2 System OFF Procedure

To turn off the PVS-500, the following turn-off sequence is recommended to avoid unnecessary wear out of the components:

- Turn OFF all three of the XGI-1500 red on/off switches on the right side of an inverter.
- Press the DPS 500 emergency OFF (EPO) button on the front panel of the converter.
- Turn the disconnect handle on the AC combiner to the OFF position
- Turn OFF all 5 DC disconnect switches on the front of the DC Recombiner
- Turn OFF the DC disconnect switches between the DCR and the batteries.

4.3 System ON Procedure

To turn on the PVS-500, use the following turn-on sequence:



- Close all PV source circuit fuse holders in the combiner boxes and close the cover.
- Turn the DC disconnect switches between the DCR and the batteries to the ON position.
- At each combiner, turn the DC disconnect to the ON position.
- Turn ON all 5 DC disconnect switches on the front of the DC Recombiner
- Turn the disconnect handle on the AC combiner to the ON position
- Release the DPS 500 emergency off (EPO) button on the front panel of the converter.
- Turn ON all three of the XGI-1500 red on/off switches on the right side of an inverter.

4.4 Replacement Fuses

Fuses in the AC Combiner

Only replace the fuses in the ACC-1500-500 AC Combiner with appropriately-rated fuses. The specification for the fuses in the AC Combiner are in **Table 4.1** below.



Table 4.1 AC Combiner Fuse Specifications

Fuse	Rating	Part Number
Inverter Output Circuit	200A, 600VAC Time-Delay Class J	Mersen AJT200N 
AC Output Circuit	600A, 600VAC Time-Delay Class J	Mersen AJT600N 

Fuses in DC Re-Combiner

Only replace the fuses in the DCR-1500-500 DC Re-Combiner with appropriately-rated fuses. The specification for the fuses in the DC Re-Combiner are in **Table 4.2** below.

Table 4.2 DC Re-Combiner Fuse Specifications

Fuse	Rating	Part Number
PV Output Circuit	400A, 1500VDC Time-Delay	Mersen Z1048684 
Inverter DC Inputs	315A, 1500VDC Time-Delay	Mersen X1048682 
DC/DC Converter	800A, 1500VDC Time-Delay	LittleFuse PSX3XLUB0800X 

5. WARRANTY & RMA INSTRUCTIONS

For warranty information, please visit: <http://solectria.com/support/documentation/warranty-information/grid-tied-inverter-warranty-letter/>

6. APPENDICES

Appendix A – Contact Information

Yaskawa Solectria Solar
360 Merrimack Street
Building 9, Suite 221
Lawrence, MA 01843 USA
Tel: 978.683.9700
Fax: 978.683.9702

Sales/General Info: inverters@solectria.com
Customer Support: 978-683-9700 x2
Website: www.solectria.com